

---

*Sanitary Sewer Overflow (SSO) Control  
and Wastewater Facilities Program*

# Pump Station Design Requirements

City of Baton Rouge/Parish of East Baton Rouge  
Department of Public Works



Submitted by

**CH2MHILL**

Prepared by: Ed Prestemon

Reviewed by: Larry Fettkether

Approved by: Jennifer Baldwin

Revision 6

September 2012



# Revision Control Log

---

Revision	Date Issued	Description of Changes	Pages Affected
1	8/2009	Revision of Program Requirements	All
2	8/2009	Revision of Program Requirements	All
3	8/2009	Revision of Program Requirements	All
4	9/2010	Revision of Program Requirements	All
5	7/2011	Revision of Program Requirements	All
6	9/2012	Revision of Program Requirements	All



# Contents

---

Section	Page
Revision Control Log.....	iii
Contents.....	v
<b>1. Introduction.....</b>	<b>1-1</b>
<b>2. Codes and Referenced Standards.....</b>	<b>2-1</b>
<b>3. Pump Station Configurations .....</b>	<b>3-1</b>
3.1 Pump Station Terminology .....	3-1
3.2 C-P Standard Pump Stations .....	3-1
3.3 Program Pump Stations.....	3-1
3.4 Large Capacity Pump Stations .....	3-2
<b>4. Site Selection.....</b>	<b>4-1</b>
4.1 Site Selection.....	4-1
4.2 Site Layout.....	4-4
4.3 Clearances.....	4-5
4.4 Intrusion Protection/Fencing.....	4-5
4.5 Access Requirements .....	4-6
4.6 Operation and Maintenance Considerations.....	4-6
4.7 Landscaping .....	4-6
4.8 Grading and Drainage .....	4-6
4.9 Pump Wash Down Facility .....	4-7
<b>5. Pump Station Hydraulics.....</b>	<b>5-1</b>
5.1 Design Flows.....	5-1
5.2 Design Criteria.....	5-1
5.3 Number and Size of Pumps .....	5-2
5.4 Pump Design Conditions .....	5-2
5.5 Forcemain and Pump Station Size Selection .....	5-3
5.6 Wet Well Volume and Level Controls.....	5-4
5.6.1 Types of Level Controls.....	5-4
5.6.2 Level Control Settings and Wet Well Volume .....	5-4
5.7 Surge Analysis .....	5-6
<b>6. Wet Wells .....</b>	<b>6-1</b>
6.1 Configurations .....	6-1
6.2 Compartmentalized Wet Wells .....	6-1



<b>Section</b>	<b>Page</b>
<b>7. Structural Requirements.....</b>	<b>7-1</b>
7.1 Geotechnical Coordination.....	7-1
7.2 Construction Type .....	7-1
7.3 Structural Design Criteria for Program Pump Stations.....	7-1
7.4 Buoyancy .....	7-2
7.5 Access Hatches .....	7-2
7.6 Handrails.....	7-3
7.7 Grating.....	7-3
7.8 Wet Well Specialties .....	7-3
<b>8. Architectural Requirements.....</b>	<b>8-1</b>
8.1 Need for Electrical Building .....	8-1
8.2 General Building Considerations .....	8-1
8.3 Wall Construction .....	8-1
8.4 Roof Structure and Roofing Materials .....	8-2
8.5 Energy and Insulation .....	8-2
8.6 Finishes .....	8-2
8.7 Security .....	8-2
8.8 Building Access .....	8-2
8.8.1 Doors and Hardware.....	8-2
8.8.2 Louvers.....	8-3
8.9 Confined Space Entry.....	8-3
<b>9. Mechanical Requirements.....</b>	<b>9-1</b>
9.1 Piping Clearances.....	9-1
9.2 Pump Spacing.....	9-1
9.3 Pump Selection.....	9-1
9.4 Pump Motor Selection Criteria .....	9-2
9.5 Pump Removal Systems.....	9-3
9.6 Pump Guide System .....	9-3
9.7 Piping Selection and Arrangement .....	9-3
9.8 Valve/Gate Selection.....	9-4
9.9 Backflow Preventer .....	9-5
9.10 Provisions for Bypassing.....	9-5
9.11 Odor Control.....	9-6
9.12 Pigging Facilities .....	9-8
9.13 Pipe Finishes .....	9-8
9.14 Pump Station Layout.....	9-8
<b>10. Ventilating and Air Conditioning Requirements .....</b>	<b>10-1</b>
10.1 Design Standards .....	10-1
10.2 Area Classifications .....	10-1
10.3 Motor Control Housing.....	10-1
10.4 Air Conditioning .....	10-1
10.5 Ventilation and Air Conditioning.....	10-1



Section	Page
<b>11. Electrical Requirements .....</b>	<b>11-1</b>
11.1 General.....	11-1
11.2 Codes.....	11-1
11.3 Electrical Service Equipment .....	11-2
11.4 Electrical Design, Power Distribution, and Motor Control Requirements.....	11-2
11.4.1 C-P Standard Pump Stations .....	11-2
11.4.2 Program Pump Stations.....	11-4
11.5 Branch Circuits.....	11-5
11.6 Conduit System .....	11-6
11.7 Conductors .....	11-7
11.8 Junction Boxes and Enclosures.....	11-8
11.9 Lighting.....	11-8
11.10 Grounding .....	11-9
11.11 Transient Voltage Surge Suppression .....	11-9
11.12 Standby Power Generator System .....	11-9
11.12.1 Generator Design .....	11-9
11.12.2 Generator Permits Description.....	11-11
11.12.3 PDP Pump Station Design Firm Responsibilities.....	11-12
11.12.4 Program Manager Responsibilities to Designers.....	11-12
<b>12. Instrumentation and Control Requirements.....</b>	<b>12-1</b>
12.1 Applicable Codes and Standards.....	12-1
12.2 Specific Control Panel and PLC System Design Requirements .....	12-1
12.2.1 C-P Standard Pump Stations (Type I and II).....	12-1
12.2.2 Program Pump Stations.....	12-1
12.2.3 PLC and Related Hardware.....	12-2
12.3 Piping and Instrumentation Drawings .....	12-3
12.4 Specifications.....	12-3
12.5 Functional Requirements for Pump Station Control \System/Sequencing.....	12-4
12.5.1 Pump Control/Sequencing for Rising Levels.....	12-4
12.5.2 Pump Control/Sequencing for Falling Levels.....	12-5
12.5.3 Emergency Pump Call Procedure.....	12-5
12.5.4 Pump Alternation .....	12-5
12.5.5 Hardwired Interlock to Prevent Starting of Standby Pump When All Duty Pumps are Running.....	12-5
12.5.6 Pump Failed to Start and Out of Service Logic.....	12-6
12.6 Interface to Collection System SCADA System .....	12-6
<b>13. Pump Station Commissioning and Startup.....</b>	<b>13-1</b>
<b>14. Pump Station Design Checklists.....</b>	<b>14-1</b>
14.1 Preliminary Design (30%) .....	14-1
14.2 60% Engineering Design.....	14-1
14.3 Final Design and Contract Documents (90% and 100% Design).....	14-1



## **Attachments**

- A Pump Station Hydraulic Curve(s) Assumptions
- B Example Pump Station Drawings
- C Example Electrical Drawings
- D Example Instrumentation and Control Drawings
- E Owner Furnished Products Specification
- F Electrical Load Estimate Sheet
- G Automatic Transfer Control System Specification
- H Pump Station Equipment Commissioning Specification and Checklist
- I Pump Station Design Checklists



# 1. Introduction

---

This document provides requirements for the design of wastewater pump stations associated with the City of Baton Rouge\ East Baton Rouge Parish (C-P) Sanitary Sewer Overflow Control and Wastewater Facilities Program. These requirements are provided to ensure consistency in the design approach used by the various Engineers, and are intended for use on all applicable projects.

While the purpose of the Requirements is to assure uniformity, it is not intended to stifle creativity, design innovation, and ingenuity of individual Engineers. Engineers shall review these requirements and adapt them for facility designs for which they are responsible. Engineers are ultimately responsible for their facility's design, and this responsibility is in no way diluted or absolved by these requirements.

The Engineer may on occasion prefer to deviate from the requirements. This deviation could be prompted by conflicts in this document, a design concept, or a feature that the Engineer believes is better or more cost-effective than the suggested remedy, or the development of a new process or equipment. In such cases, the engineer shall immediately bring this matter to the attention of the Program Manager (PM), who will review project-specific deviations. The proposed deviation shall be discussed verbally with the Project Manager within one week from the Engineer's determination of the need for such deviation. The engineer shall also request permission to deviate from the requirements by completing and submitting the form presented in Attachment A of the *Requirements for Engineers*. The proposed deviation may be accepted as presented, accepted with identified changes, or not accepted. If the decision cannot be made immediately, the Project Manager will notify the engineer of the turnaround time expected to make a determination on the proposed deviation; this period of time will vary depending on the deviation request. Accepted deviations will also be further considered for possible changes to the program-wide requirements. The Project Manager reserves the right to disallow the deviation from the requirements.



## 2. Codes and Referenced Standards

---

The design of pump stations and ancillary facilities shall conform to the latest Program Design Requirements and the latest adopted version of all applicable local, state, and federal regulations. Applicable codes and standards and their conditions shall be verified at the time of final design work. Program Design Requirements are available on the Program web site at [www.brprojects.com/sewer/pages/contractor\\_guidelines.htm](http://www.brprojects.com/sewer/pages/contractor_guidelines.htm).



# 3. Pump Station Configurations

---

## 3.1 Pump Station Terminology

The pump stations to be constructed as part of the Program are categorized into three general types:

- C-P Standard Pump Stations
- Program Pump Stations
- Large Capacity Pump Stations

Most of the general requirements included in this document, such as requirements for pump station hydraulics and site selection, apply to all three types of pump stations. Most specific requirements are noted as applying to one or more specific pump station type. The Engineer shall contact the Project Manager if there are questions concerning the applicability of the requirements on a specific project.

Additional pump station design requirements will be included in the Project Definition.

## 3.2 C-P Standard Pump Stations

In these Design Requirements, a C-P standard pump station is defined as one with two or three constant or variable speed pumps installed. All C-P standard pump stations shall be designed as submersible pump stations and shall have a minimum of two rail-mounted pumps (one duty pump and one standby pump) or three rail-mounted pumps (two duty pumps and one standby pump). They shall conform to C-P Standard Specifications and Details.

The C-P standard pump stations have been split into two groups. Type I pump stations are duplex and triplex stations that have electrical and controls equipment in a field panel. Type II pump stations are triplex stations that have electrical and controls equipment in an electrical building.

Standard pump stations shall also incorporate standby power generation as described in these requirements.

## 3.3 Program Pump Stations

In these Design Requirements, a Program pump station is defined as one with all of the following features:

- Four, six, or eight pumps
- Less than or equal to 500 horsepower (hp) per pump
- Less than 50-foot wet well depth, measured from grade to the top of the bottom slab of the wet well
- Capacity of 50,000 gallons per minute (gpm) or less



A minimum of four, variable speed pumps are required for these stations. Firm capacity of pump stations is defined as the capacity of the station with the largest capacity pump out of service.

All Program pump stations shall be designed as variable speed submersible pump stations using rail-mounted pumps with permanently mounted pump base and discharge pipe. Pump stations shall be designed with an even number of pumps, including duty and standby pumps. The required number of pumps shall be based on the ratio of peak wet weather to average dry weather flows. Also, with one pump running at minimum speed, a minimum velocity of 2 feet per second (fps) in the forcemain shall be the goal, but not a requirement.

For Program pump stations with four or more pumps, the Engineer shall use a two-compartment wet well to facilitate maintenance. Compartments shall be capable of being isolated from each other with sluice gates, electrically operable from a concrete slab at or abovegrade.

### 3.4 Large Capacity Pump Stations

In these Design Requirements, a large capacity pump station is defined as one with at least one of the following features:

- A firm capacity in excess of 50,000 gpm
- Wet well in excess of 50 feet deep
- More than 8 pumps
- More than 500 hp per pump

The Engineer shall provide dual wet well compartments for all large capacity pump stations. Also, submersible pump stations shall be used if possible for all large capacity pump stations. Wet well/dry well pump stations may be used for large capacity pump stations if agreed to by the Louisiana Department of Public Works (DPW) and Project Manager.

Design of a large capacity submersible or wet well/dry well pump station is not specifically covered under these standards and shall be based on project-specific evaluations supplemented by applicable portions of these requirements.

# 4. Site Selection

---

## 4.1 Site Selection

Site selection is critical in producing a satisfactory permanent facility with attractive life-cycle costs. Site evaluation by the Engineer shall include assessment of the following:

- Visual impact on the neighborhood. The pump station shall be sufficiently set back from the property line to the fence line to accommodate a landscape buffer zone. To the greatest extent, features shall be located below grade.
- Elevation of site structures. Top of pump station structures or grade level floors, top of valve vaults, and concrete pads for pump control panels, electrical rooms and generators shall all be at the same elevation. This common elevation shall be a minimum of 1 foot above the highest elevation of the following:
  - Base flood (100-year flood)
  - Record inundation
  - Center line of adjacent street
  - Nearest controlling sanitary sewer manhole

The elevation information listed above can be obtained by submitting a Flood Zone Determination Form to the C-P Inspections Division. If the existing grade at the pump station is 3 feet or more below the 100-year flood elevation or record inundation, then the top of the pump station structures may be equal to the highest of the two, rather than 1 foot above. The detail shown in Figures 00-S-2001 and 00-S-3001 shall be used for pump stations 3 feet or more below the 100-year flood elevation or record inundation, whichever is the highest, where the site does not have to raise the grade.

- Access for pump removal equipment. The site shall include sufficient pavement area and clearance to accommodate full movement and operation of the C-P's vehicles with outriggers, including a 10-ton truck-mounted hydraulic crane utilized for pump removal work (vehicle size and shape to be confirmed by Engineer with Project Manager). This includes being able to safely navigate around overhead interferences, such as electrical lines. Pump/motor combinations that weigh in excess of 10 tons shall have permanently installed bridge cranes for equipment removal.
- Vehicle access. The site shall accommodate an entrance gate with sufficient setback to allow entrance without blocking the main roadway.
- Clearances for construction and maintenance of pumps, generators, odor control equipment, and electrical equipment.
- Site security and fencing.
- Structure depth and its potential impact on adjacent areas.

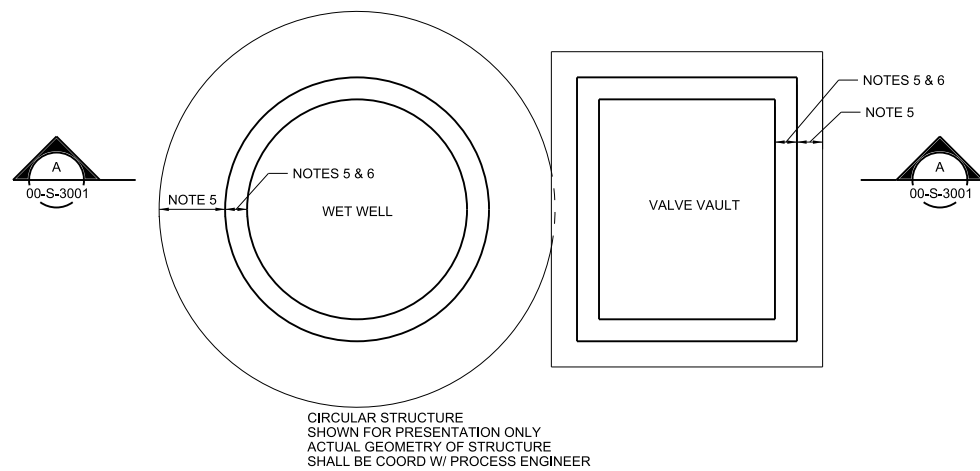

**FOUNDATION PLAN**  
NTS

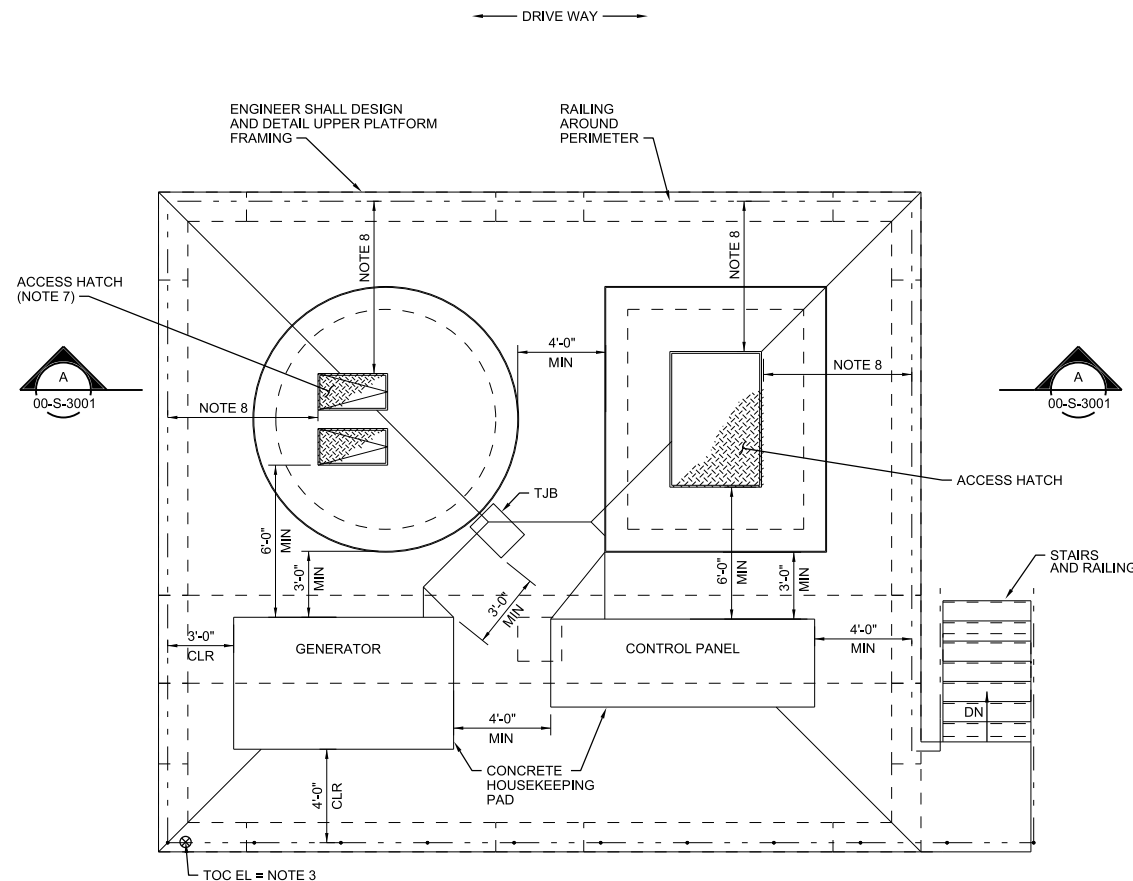

**TOP PLAN**  
NTS

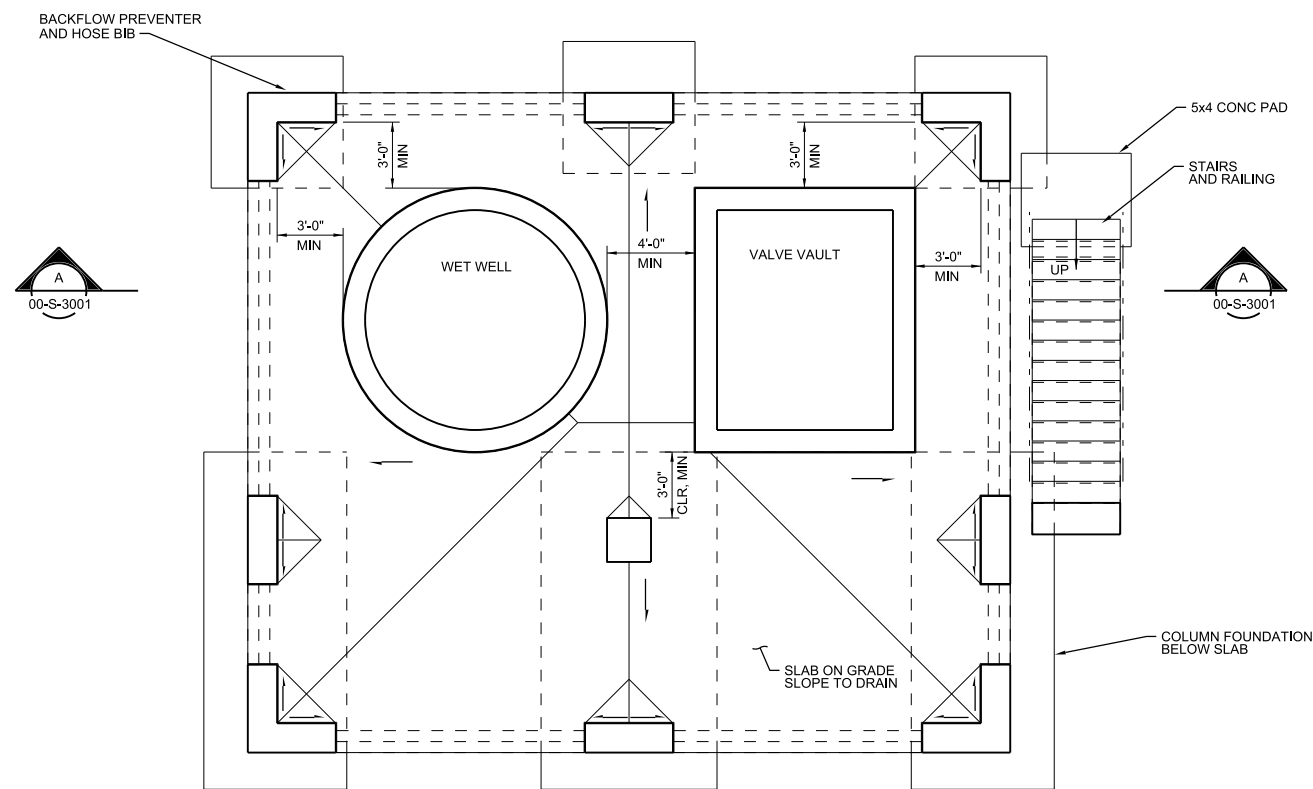

**INTERMEDIATE PLAN**  
NTS

**NOTES TO ENGINEER FOR PUMP STATIONS AND VALVE VAULTS:**

1. PROVIDE SPECIFIC CODE AND DESIGN INFORMATION IN GENERAL NOTES OR ADD INFORMATION DIRECTLY TO A DRAWING.
2. SELECTION OF STRUCTURAL MATERIALS AND DESIGN AND DETAILING OF STRUCTURE SHALL BE IN ACCORDANCE WITH THE FOLLOWING STANDARDS AS APPLICABLE. IN THE EVENT OF CONFLICTING REQUIREMENTS THE MOST STRINGENT REQUIREMENTS SHALL APPLY UNLESS OTHERWISE NOTED:
  - A. ASTM C 478, STANDARD SPECIFICATION FOR PRECAST REINFORCED CONCRETE MANHOLE SECTIONS.
  - B. ASTM C 890, STANDARD PRACTICE FOR MINIMAL STRUCTURAL DESIGN LOADING FOR MONOLITHIC OR SECTIONAL PRECAST CONCRETE WATER AND WASTEWATER STRUCTURES.
  - C. ASTM C 913, STANDARD SPECIFICATION FOR PRECAST CONCRETE WATER AND WASTEWATER STRUCTURES.
  - D. ACI 350, CODE REQUIREMENTS FOR ENVIRONMENTAL ENGINEERING CONCRETE STRUCTURES.
  - E. ACI 350.3, SEISMIC DESIGN OF LIQUID CONTAINING CONCRETE STRUCTURES.
  - F. INTERNATIONAL BUILDING CODE, 2009 EDITION.
  - G. SANITARY SEWER OVERFLOW (SSO) CONTROL AND WASTEWATER FACILITIES PROGRAM PUMP STATION DESIGN REQUIREMENTS BY CITY OF BATON ROUGE/PARISH OF EAST BATON ROUGE DEPARTMENT OF PUBLIC WORKS.
3. DESIGN FLOOD ELEVATION SHALL BE AT THE 100-YEAR FLOOD ELEVATION, OR RECORD INUNDATION ELEVATION, WHICHEVER IS HIGHER. TOP OF PRECAST STRUCTURE SHALL BE SET AT THE DESIGN FLOOD ELEVATION.
4. FACTOR OF SAFETY AGAINST UPLIFT SHALL BE AS FOLLOWS WHEN ONLY DEAD WEIGHT OF STRUCTURE AND SOIL DIRECTLY OVER TOE OF FOUNDATION (IF ANY), ARE USED FOR RESISTANCE:
  - A. FS = 1.25 AT 100 YEAR FLOOD ELEVATION
  - B. FS = 1.1 AT RECORD INUNDATION ELEVATION.
5. WHERE THERE ARE NO SPACIAL CONSTRAINTS ON SITE, USE STANDARD PRECAST UNITS ON A CAST-IN-PLACE CONCRETE BASE SLAB. RESIST BUOYANCY FORCE BY EXTENDING BASE SLAB BEYOND PRECAST WALLS, AND ENGAGE WEIGHT OF SOIL OVER TOE OF FOUNDATION IN CONJUNCTION WITH DEAD WEIGHT OF WALLS. MAXIMUM WALL THICKNESS = 1'-0".
6. WHERE SPACIAL CONSTRAINTS OF SITE DO NOT ALLOW ENLARGED BASE SLAB, SPECIFY MINIMUM THICKNESS OF WALL PRECAST OR CAST-IN-PLACE WITH BASE SLAB NECESSARY TO RESIST BUOYANT FORCE.
7. SEE PUMP MANUFACTURERS REQUIREMENTS FOR SIZE OF ACCESS HATCH.
8. MINIMUM 3'-0" CLEAR BETWEEN HATCH AND RAILING. THIS MAY REQUIRE THAT TOP SLAB BE CANTILEVERED BEYOND PUMP STATION WALLS.
9. PUMP STATION, VALVE VAULT, AND GENERATOR PLATFORM MAY EACH BE SEPARATE STRUCTURES WITH CONNECTING "WALKWAY". USE A SINGLE SET OF STAIRS FOR ACCESS TO TOP PLATFORM.
10. PILE FOUNDATION SYSTEM MAY BE REQUIRED BASED ON GEOTECHNICAL RECOMMENDATIONS.
11. DESIGN ENGINEER SHALL BE RESPONSIBLE FOR DETAILED DESIGN.

SHEET NO.	00-S-2001
DESIGNED BY	M. CHRZANOWSKI
CHECKED BY	J. THORNTON
DATE	APRIL 2012
PROJECT	EAST BATON ROUGE
CITY	BATON ROUGE
PROJECT NO.	350569
DATE	APRIL 2012
SHEET	OF 127
NO.	DATE
BY	REVISION DESCRIPTION



DPW WASTEWATER SYSTEM SCADA  
STRUCTURAL CONCEPT  
PUMP STATION AND VALVE VAULT - PLANS



CH2MHILL  
700 MAIN ST. SUITE 400  
BATON ROUGE, LA 70802  
(225) 381-8454



NOT TO SCALE

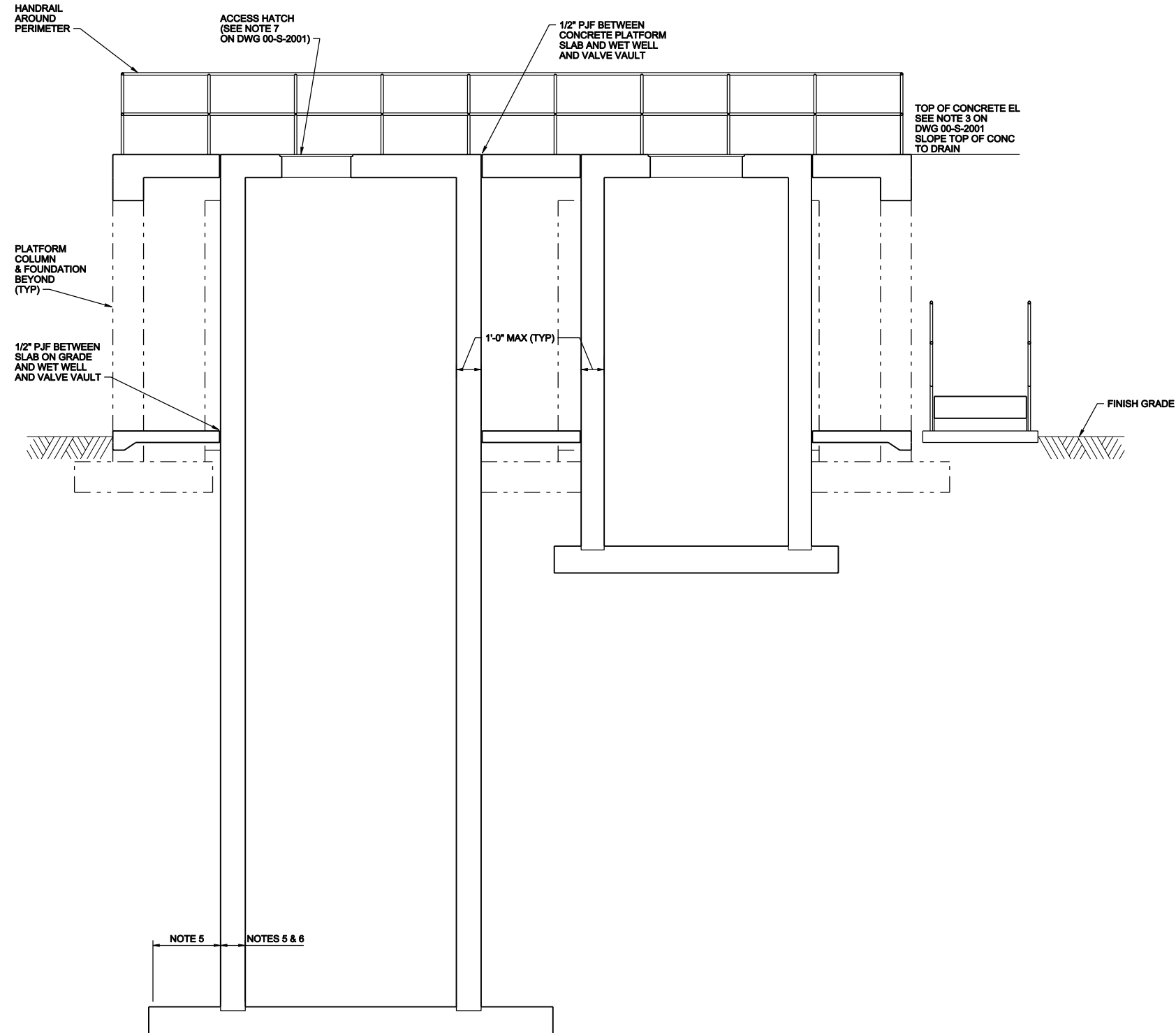



**A** SECTION  
3/8"=1'-0"  
00-S-2001

NOT TO SCALE

SHEET NO. 00-S-3001		EAST BATON ROUGE	
DESIGNED BY M. CHRZANOWSKI		PARISH BATON ROUGE	
CHECKED BY J. THORNTON		CITY	
DATE APRIL 2012		PROJECT 350589	
SHEET 127		OF 127	
REVISION DESCRIPTION			
NO.	DATE	BY	
			
DPW WASTEWATER SYSTEM SCADA STRUCTURAL CONCEPT PUMP STATION AND VALVE VAULT - SECTION			
PLOT DATE: 20120424 PLOT TIME: 9:51:06 AM FILENAME: 00-S-3001_350589.dgn			
			
CH2M HILL 700 MAIN ST. SUITE 400 BATON ROUGE, LA 70802 (225) 381-8454			



- Odor potential and impact on neighborhood. To the extent possible, pump stations shall be oriented according to the prevailing wind direction to minimize potential hydrogen sulfide odors in adjacent areas and for gases entering electrical panels or control building intake grills.
- Noise potential and impact on neighborhood. To the extent possible, orient the engine generator, building air intake louvers, and building, wet well, and odor control fans to direct noise away from the adjacent neighborhood. An effort also shall be made to make the architecture of the pump station blend with the local surroundings.
- Pump station shall be located on a full parcel. If the pump station will be located in a residential area, an entire residential lot shall be obtained.
- Land acquired shall be dedicated (Fee Title to C-P).

Pump stations shall not be located on the following:

- Road and street rights-of-way.
- Servitudes.
- Excessively small parcels.
- Areas where future maintenance access, security, or odor mitigation may become difficult.
- A site with topography that prevents the top of the station from being located above the 100-year flood elevation, or where the site may not be accessible during a 25-year flood event.

The Engineer shall work with the Project Manager and C-P in securing neighborhood involvement during initial site selection and design development. The Project Manager will coordinate land acquisition.

If the elevation of the new site structures will be more than 3 feet above the existing grade, the Engineer shall notify the Project Manager to determine the structure elevations to be used. If the elevation of the new site structures will be within 1 foot of the top of the fence, an additional special visual barrier shall be evaluated, with Project Manager approval.

## 4.2 Site Layout

Planning and design shall specifically address the visual impact on the neighborhood; access to the site for normal service trucks; clearance/separation from property lines and adjacent facilities; potential odor impacts; and site security.

The pump station shall be oriented according to prevailing wind direction so as to minimize hydrogen sulfide gases entering control building intake grills or electrical panels whenever possible. If main electrical and control panels shall be installed outside, they shall be out of direct sunlight and located in weather-proof enclosures.

Equipment shall be oriented to minimize sound transmission to the adjacent neighborhood. Sources of sound, such as the engine generator, building air intake louvers, and odor control fans shall be located to direct noise away from the adjacent neighborhood, or so that the



pump station building blocks sound transmission to the neighborhood. Other noise control provisions, such as high mass walls may be considered if necessary.

For single-lot sites, the pump station shall be positioned centrally on the lot or so as to maximize separation between neighboring structures, within the clearance guidelines described below.

The Engineer may prepare a preliminary site layout plan. The plan shall be submitted for review and approval prior to the 30% design completion date. If required by the Project Definition, the preliminary site plan will be submitted as part of a formal 15% submittal.

The preliminary site plan shall include, at a minimum, the following information:

- Dimensions between structures
- Distances from structures to property lines
- Location of all underground piping and utilities, both existing and proposed
- Location of overhead obstructions, such as power lines or trees
- Limits of paving
- Existing ground elevations
- Location of fencing and gates

## 4.3 Clearances

The site design shall include the following clearances:

- At least 30 feet from all sides of the structure to the property lines, where space is readily available.
- At least 20 feet from the structure to property lines on at least two sides, when available land is limited.
- Wet well tops extending 8 to 12 inches above the finished grade without berming up to top slab elevation.
- Minimum setback distances from all property lines shall be as governed by ordinances. Particular attention shall be paid to the clearances required in National Fire Protection Association (NFPA) 30 between the generator base-mounted fuel tank and property lines or the edge of public rights of way.

## 4.4 Intrusion Protection/Fencing

Site security shall be provided by a full-perimeter intruder resistant fence, including one 12-foot-wide, inward-opening, double-leaf swing gate secured with chain and keyed padlock. The fence shall be a 6-foot high wooden fence in accordance with C-P Standard Details. Other security measures will be considered on a case-by-case basis, if special conditions or requirements dictate.



## 4.5 Access Requirements

The site security fence and entrance gate shall be placed far enough from the street to allow maintenance vehicles to be off the main roadway when the operator stops to unlock the gate.

Access roadway shall be concrete pavement and width shall be 12 feet. Turnout radius (inside) shall be at least 50 feet, or long enough to prevent truck or crane wheel overrun from the pavement. For Program pump stations, access roadway shall allow for trucks or cranes (20 ton mobile crane) to turn around and to safely enter the main roadway from the turnaround points. Curbs on access road shall not be required.

The site shall be reliably accessible during a 25-year flood event.

## 4.6 Operation and Maintenance Considerations

The pump station, including all mechanical and electrical equipment, shall be designed to withstand and operate during a 100-year flood event, including wave action.

The site layout shall address access and setting of vehicles that will lift out submersible pumps, the engine generator, or other equipment and to allow easy access to fuel the generator if a diesel engine is used. Site size, facility locations, clearance areas, overhead utilities, and orientation of hatches shall be coordinated with the setting position and lifting capacity of a maintenance crane.

Paving into the site and around the inside of the site shall be Portland cement concrete of sufficient design and thickness for anticipated loads.

Portland cement concrete pavement with minimum drainage slopes shall be provided around the pump station, piping, valves, electrical buildings, or control panels. The pavement shall be wide enough for proper mobility of the appropriate vehicle, but not less than 12 feet. In areas that are not accessible to vehicular traffic, concrete shall extend a minimum of 4 feet from all structures and control panel bases. To minimize grounds maintenance and such items as grass and weed cutting, the remaining area inside of the perimeter fencing shall be covered with 4 inches of crushed limestone with geotextile fabric.

Pipe bollards shall be shown on the drawings around the pump station for protection of equipment and the generator fuel tank.

## 4.7 Landscaping

Pump station site designs need to be safe and simple. Aesthetically, they shall blend into the surrounding landscape. All disturbed areas not paved or covered with limestone (outside the fenced area) shall be covered by sod.

## 4.8 Grading and Drainage

Pump station sites shall be graded so that surface water does not drain into the wet well, meter vault, or valve vault. Slopes shall not be greater than 1 foot vertical to 6 feet horizontal. Storm water shall be collected in pipes or swales, for discharge or retention



onsite in accordance with local requirements. The Engineer is responsible for investigating all local storm water issues and incorporating specific requirements into the project design.

All sites greater than one acre shall be analyzed to determine existing drainage patterns and to identify receiving outfalls or structures. The existing patterns must be adhered to and the receiving outfalls shall be upgraded to accommodate any increased flow for which they were not designed to accept. If this is not practical or is cost prohibitive, detention may be required. If the site is located on an outfall (stream, canal, ditch, and so forth) and the upstream watershed is 10 times greater than the site area being developed, no analysis is required.

## 4.9 Pump Wash Down Facility

Each Program pump station with four or more pumps shall contain a three-sided walled (6 feet high) pump wash down facility. It shall be sized to accommodate the largest pump, with a 3 feet clearance around the pump. The facility shall consist of a minimum 12-inch reinforced, sealed concrete slab with concrete masonry unit (CMU) walls with an epoxy coating. The slab shall be sloped to the rear wall with a 6-inch valved drain, which shall terminate in the pump station wet well.



# 5. Pump Station Hydraulics

---

## 5.1 Design Flows

All pump stations shall be designed to carry the estimated design wet weather flow, from the area ultimately contributing to the pump station, by the corresponding sanitary sewer system. The Project Manager will provide the hydraulic design criteria. The Engineer is responsible for submitting written requests to the Project Manager for additional information.

Peak wet weather hydraulic design for existing sewers and pump stations shall be based on the flow data provided by the Project Manager. The Project Manager will furnish the Engineer with the following design flows as part of the Project Definition:

- Average day dry weather flow rate (ADWF)
- Peak wet weather design flow rate (PWWF)

The minimum flow condition is not provided to the Engineer, since the InfoWorks™ model does not include minimum flows. The Engineer must determine the minimum flow condition.

If the discharge forcemain is not part of the design scope of work or is part of the Suburban Transportation Network (STN) forcemain system, the Project Manager will furnish the following additional information:

- Corresponding boundary system curves
- Pump hydraulic design point

A form showing the standard information to be provided by the Project Manager to the Engineer is included in Attachment A.

## 5.2 Design Criteria

The following design criteria shall be considered for hydraulic design:

- Hazen-Williams C-values shall be as defined further in this document.
- Hydraulic Institute Engineering Data Book, or other recognized reference for hydraulic data, shall be used for fitting and valve velocity head K-factors.
- The velocity of the pump suction line (where provided) shall be between 3 to 5 fps and shall be within pump manufacturer's recommendations.
- The velocity of the pump discharge piping shall be generally 5 to 10 fps at design peak wet weather flow. Pipe velocities shall be a minimum of 2 fps with one pump operating at minimum speed, if practical.
- Net positive suction head (NPSH) calculations shall be provided by the Engineer, at design and boundary conditions. The NPSH available, as calculated by the Engineer, shall be compared to the NPSH required by the pump manufacturer. The calculated



NPSH available shall be a minimum of five feet greater than the NPSH required at design and boundary conditions.

- For submersible pump stations, a minimum of two feet shall be added to the manufacturer recommended minimum submergence requirements.
- The receiving sewer shall have sufficient capacity to accept the peak discharge rate from the proposed forcemain while not surcharging (i.e., the HGL in the receiving sewer shall be beneath the pipe's crown). Surcharging of receiving sewers is not allowed. This data will be provided to the Engineer by the Project Manager.
- Pump stations, including sumps and baffle walls, shall be hydraulically designed per the latest version of the Hydraulic Institute Standards and the recommendations of the ITT/Flgryt Corporation for submersible pumps.
- Engineers shall obtain a certification from the pump manufacturer that the pumps will perform in the designed pump station layout.
- For pump stations with capacities greater than 10 million gallons per day (mgd) (7,000 gpm), the pump station and sump shall be modeled with a physical hydraulic model to confirm hydraulic design. Modeling goals and objectives shall be submitted to the Project Manager for review prior to model development.

### 5.3 Number and Size of Pumps

A larger number of small pumps is preferred over a fewer number of large pumps. This limits the unit size and, thus, reduces the cost of repairs. In addition, smaller motors have a lower electrical demand charge associated with starting the pumps. Also, several smaller pumps can cover a greater number of flow points than fewer large pumps. However, it is recognized that a smaller number of larger pumps can generally result in the smallest overall footprint for the pump station, providing an opportunity to reduce structural cost.

Lower rotational (less than 1,900 revolutions per minute [rpm]) speed pumps are more desirable, since they reduce pump wear. For a specific application, if there are comparable pump options available with different pump speeds, the lowest pump speed shall be selected.

For Program pump stations, where the peak wet weather flow to average dry weather flow ratio is greater than 4:1, four to eight equally sized pumps shall be used. In cases where the flow ratio is high or the design point and run-out curve cannot be met with equally size pumps, smaller capacity dry weather pumps may be considered in addition to larger capacity wet weather pumps.

### 5.4 Pump Design Conditions

The Engineer shall prepare a set of pump curves to simultaneously represent the operation of the selected pumps and forcemain under a wide range of situations. The Engineer shall analyze pump performance at the following conditions provided by the Project Manager in the Project Definition:

- Pumping at minimum head (pumps on at high wet well level, discharging to the lowest possible elevation), and a C-value of 150, run-out boundary condition.





- Pumping at design head (pumps off at low wet well level, discharging to highest possible elevation), and a C-value as noted below.
- System curves shall be provided at C = 100 at maximum static head, C = design point defined below, and C = 150 at minimum static head. Pump curves shall include manufacturer's pump curve, modified pump curve including all pump station losses, and single and multiple pumps running, at full and reduced speeds. Operating curves shall be provided to include both system and pump curves, and all operating points shall be identified. System curves shall be generated by the Project Manager if the Engineer contract does not include forcemain analysis or design.

At a minimum, individual pump performance requirements (such as flow, head, brake horsepower [BHP], efficiency, and NPSH) shall be specified for the following conditions:

- Boundary condition: C=100 (to be within pump operating range) at maximum static head
- Design point 8-inch pipe and smaller: C=110 at maximum static head
- Design point 10-inch to 18-inch pipe: C=115 at maximum static head
- Design point 20-inch to 42-inch pipe: C=120 at maximum static head
- Design point greater than 42-inch pipe: C=130 at maximum static head
- Boundary condition: C=150 (run-out) (to be within pump operating range) at minimum static head

Pumps shall be selected for steep pump curves. Additionally, pump efficiency may be considered. Pump curves shall be defined by: design point, shut-off head, and two additional points on either side of the design point at the two boundary conditions.

The Engineer shall provide a hydraulic profile of the entire pump station/forcemain system, and this profile shall show the hydraulic grade-line from the pump station to the discharge location(s). Where the forcemain contains intermediate high points the engineer shall analyze whether an intermediate high point becomes the controlling discharge elevation under some flow conditions. If the Engineer's contract does not include forcemain analysis or design, this information shall be provided by the Project Manager.

The Engineer shall provide detailed calculations to the Project Manager for information and comment.

## 5.5 Forcemain and Pump Station Size Selection

Forcemain size shall be based on criteria provided by the Project Manager in the *Conveyance Design Requirements*. Typically, the forcemain/pump system will be sized to limit the total dynamic head (TDH) to 150 to 200 feet. If forcemain analysis and design is not included in the Engineer's scope, or if an existing forcemain is to be utilized, forcemain size and elevations shall be provided by the Project Manager.

Wet and dry weather flow variations beyond a maximum 4:1 ratio influence the number of pumps. In general, increasing variance between wet and dry weather flows increases the number of pumps for proper operation.

Pumps, their supports, the piping, and the electrical facilities shall be selected to allow easy replacement. Generally, pumps shall not be selected with the largest or smallest possible impeller, but shall be sized to accommodate a different impeller in the future.



Pump sizing and selection shall be achieved with the largest pump out of service – this is termed the “firm pumping capacity.”

## 5.6 Wet Well Volume and Level Controls

### 5.6.1 Types of Level Controls

The primary device for pump station level measurement for Program pump stations and for Type II C-P standard pump stations shall be a bubbler tube/captive air system. Captive air systems are to be provided for Type I C-P standard pump stations, and shall be as shown in the C-P standards. Captive air systems shall use optical float switches to provide HIGH-HIGH and LOW-LOW alarm and back up pump control.

A bubbler system shall be provided for stations with three or more pumps with an electrical/control building with dual air compressors, each mounted on its own receiver. The air compressors and associated bubbler tube controls shall be housed in a control panel and shall be located in the pump building. Bubbler systems shall use pressure switches on the bubbler tubes as the secondary control method for backup of the Programmable Logic Controls (PLC)-operated pump control system. Since pressure switches are discrete devices, they shall be used to indicate LOW-LOW or HIGH\_HIGH levels, as well as intermediate levels, if desired. Pumps shall operate automatically, based upon the water level in the wet well. Normal pump operation will be controlled by the PLC-based control system, but the pressure switches will provide the backup pump control in the event of a PLC failure. For pump stations with two or more wet wells, provide one bubbler panel with two bubbler tubes, one to each wet well, and locate the bubbler control panel in the electrical/control building. The bubbler tubes shall be provided with a valve on each tube to the bubbler panel. A connection with a shut off valve will be added upstream for connection to the air pump for startup.

### 5.6.2 Level Control Settings and Wet Well Volume

The peak wet well elevation shall be maintained at one foot below the lowest inlet pipe invert discharging into the wet well for influent pipes less than 25 inches. Therefore, this maximum elevation shall be used to determine the LEAD PUMP ON elevation for a two-pump station, or the last LAG PUMP ON elevation for a three-pump or more station. The wet well high-level alarm shall be maintained at the lowest inlet pipe invert discharging into the wet well. Upon approval from the Project Manager, and based upon a case-by-case analysis, the high water level may be allowed to back up into the pump station influent sewer, for influent sewers greater than 29 inches, at a maximum depth of 0.5D above the sewer invert where it enters the wet well, where D is the inside diameter of the influent sewer.

The operating depth for LEAD PUMP ON level controls for pump stations with three or more pumps shall be based on the minimum allowed cycle times between pump starts, accounting for the incrementally reduced pumping capacities. Pump cycle times shall be calculated assuming one pump out of service.

A minimum of 1.5 feet shall be provided between incremental PUMP ON and PUMP OFF elevations.



### Wet Well Volume for Variable Speed Pumping

The pumping range in the wet well with variable speed pumps shall be a minimum of 1.5 feet per firm pump. For instance, if there are four installed pumps, the pumping range will be 1.5 feet x 3 pumps = 4.5 feet. Therefore, the ALL PUMPS OFF elevation for variable speed pumps shall be below the ALL PUMPS ON elevation by 1.5 times the number of firm pumps (in feet).

### Wet Well Volume for Constant Speed Pumping

These requirements only apply to C-P standard pump stations.

The PUMP OFF elevation shall be determined using the following equation:

$$E_{\text{OFF}} = E_{\text{ON}} - \frac{V_e}{A_w}$$

Where  $V_e$  is the effective pumping volume in cubic feet, and  $A_w$  is the wet well cross sectional area in square feet. The effective pumping volume may be estimated as follows:

$$V_e = \frac{Q * t_{\text{min}}}{7.481 * 4}$$

Where  $Q$  is the design wet weather flow rate in gallons per minute,  $V_e$  is the effective pumping volume in cubic feet, and  $t_{\text{min}}$  is the minimum time interval in minutes allowed in one pumping cycle. Minimum cycle time ( $t_{\text{min}}$ ) is calculated as follows:

$$t_{\text{min}} = \frac{60 \text{ min}}{\text{No. Cycles/hour}}$$

The time within one pumping cycle shall be limited in order to prevent motor insulation failure due to overheating. When a motor starts, the inrush current may be significantly higher than normal operating current, resulting in significant heat generation. Hence frequent motor starts do not give the motor adequate time to “cool down” between starts. The Engineer shall also refer to NEMA standards.

Pump cycle times shall generally be per the manufacturer’s recommendation, or limited to a minimum cycle time of 15 minutes (at design flow), per “Ten State Standards”, in the absence of a manufacturer’s recommendation.

For cycle times less than 15 minutes at design flow, the Engineer shall obtain written verification from the pump and motor manufacturer that cycle time is acceptable. Pump cycle times shall not exceed manufacturer recommendations and NEMA standards.

Wet well storage volume shall be such that detention time is less than 30 minutes at dry weather flow, per “Ten State Standards”, to minimize septic conditions and odor generation. For low flow conditions, controls shall cycle the pumps at a minimum of once every 30 minutes. For pump stations where 30 minute detention time cannot be achieved in combination with the minimum pump cycle time, the Engineer shall notify the Project Manager.



## 5.7 Surge Analysis

All pump station designs shall include a surge evaluation. The surge analysis procedures indicated below are generally adequate for C-P standard and Program pump stations. Larger facilities require special, detailed surge analysis. Engineers shall perform a more detailed surge analysis if they determine it is needed to adequately evaluate surge, or if it is required by the Project Definition. Where the discharge forcemain is not part of the pump station design, the Project Manager will provide the Engineer with the information necessary to complete the surge analysis.

Surge pressure in a forcemain is created by any change from a steady state flow condition; the change may range from only slight pressure or velocity changes to sufficiently high vacuum pressure or high pressure wave conditions. Events that introduce serious risk from surge are uncontrolled power failures resulting in a pump trip; rapid opening, closing, or regulating of valves; and starting or stopping of pumps.

Surge control is more critical for pumping station power failure conditions and for high specific speed pumps that cannot be operated against closed valves. Various equipment and means may prevent damaging surges, including:

- Automatically operated valves at the pump discharge
- Surge relief valves
- Surge tanks
- Air-oil cylinder cushioned pump check valves

If the down-surge gradient drops below the pipeline gradient, water column separation or vapor cavities (negative pressure) may occur. Damaging secondary surge pressures can result when the vapor cavity collapses. Use of air release/vacuum relief assemblies control secondary surges but have a limited effective area along the pipeline.

The magnitude of surge pressure is a function of the following:

- Change in the velocity of flow
- Density of the fluid
- Speed of the pressure wave within the fluid and piping system

The speed or velocity of the pressure wave is a function of the following factors:

- Pipeline material
- Pipeline wall thickness
- Pipeline diameter
- Specific gravity and bulk modulus of the fluid being pumped

The magnitude of surge pressure for a given change in velocity is expressed by the Joukowsky Equation, for instantaneous change or stoppage of flow, or:

$$h_{max} = a/g *dV$$

Where:

- |           |   |  |
|-----------|---|--|
| $h_{max}$ | = | change in pressure head in feet  |
| $a$       | = | pressure wave speed in fps (for the fluid in a specific pipe material) |
| $g$       | = | 32.2 fps <sup>2</sup>  |
| $dV$      | = | change in flow velocity of the pumped fluid in fps                     |



The Joukowsky Equation shall only be used for a preliminary estimate of the surge potential of the system. The equation is limited in that it will only accurately represent surge pressure head changes for single pipes with near-instantaneous flow velocity changes. In more complex situations, such as pumping stations or pipe networks, this equation tends to predict excessive pressures.

Whenever the pressure class of the forcemain would have to be increased due to the effects of surge or cavitation, the Engineer shall use a computer model capable of performing transient analysis to perform a more detailed assessment of surge potential. This often provides a lesser, but more accurate, design pressure. It also provides insight into potential problems, such as minimum and negative pressures within a pipeline. Accurate design pressures may allow the Engineer to specify less costly materials while still maintaining an appropriate safety factor.



# 6. Wet Wells

---

## 6.1 Configurations

For C-P standard pump stations, circular wet well configurations with a minimum inside diameter of 8 feet or maximum of 12 feet may be used for non-compartmentalized wet wells. Floor bottoms shall be sloped toward pump inlets to minimize grit accumulation. Compartmentalized wet wells shall have a rectangular configuration.

If the C-P standard precast concrete wet well with integral precast concrete valve vault detail is desired for use on a site with limited available land, the Engineer must get special permission from the Project Manager and the C-P. If this detail is used, the Engineer must design the integral valve vault for cantilever, with no support from the wet well below.

Wet wells shall be accessed directly and only from outside atmospheric areas.

## 6.2 Compartmentalized Wet Wells

Wet well compartments are required for Program pump stations or large capacity pump stations with four or more pumps. Wet well compartments essentially divide the well into separate, isolatable chambers with electrically operated, fabricated stainless steel slide gates in accordance with AWWA C561. These compartments allow maintenance or cleaning of the wet wells, submersible pump base flange repair, or the replacement of guide rails or guide cables without bypassing the pump station.

The dividing wall between wet well compartments shall extend to the top of the wet well, so that when the gate is closed the wet well being dewatered and potentially accessed is maintained dry and not subjected to gases from the adjacent wet well. This will serve to protect workers entering the dewatered wet well. A fabricated stainless steel slide gate is to be located in the dividing wall for hydraulic balancing when the wet well is compartmentalized.

A common influent chamber is required. All influent pipes will flow into this common chamber and the flow will split from there, through electrically operated, fabricated stainless steel slide gates, to the two wet well compartments.

At a minimum, wet wells (if odor control is not provided) shall be designed for passive gravity ventilation with a gooseneck vent pipe and equipped with non-corroding insect screens. Vent rates shall not create more than 1 inch of static pressure or vacuum to be applied to the structure at peak pump station design flow. Vent opening (bottom of gooseneck) shall be at least two feet above the 100-year flood elevation.

Concrete fillets shall be provided per Hydraulic Institute Standards to prevent solids build up in the influent chamber of the wet well and around the pumps.

The wet well hydraulic entrance with baffle shall be designed to minimize turbulence, air entrainment, and potential hydrogen sulfide gas release.



A depressed sump (4 feet x 4 feet x 2 feet deep) is to be provided for each wet well chamber for final compartment dewatering. A 4 foot x 6 foot access hatch shall be provided for access to the sumps. The C-P will provide portable pumps to dewater the sumps.



# 7. Structural Requirements

---

## 7.1 Geotechnical Coordination

At least one boring shall be located below the foundation of the pump station with a diameter, length, or width less than 20 feet. At least two borings shall be located below pump stations with diameter, length, or width greater than or equal to 20 feet. Depth of borings shall be extended at least 20 feet below the planned foundation base; actual depth is to be determined by the Engineer and their geotechnical engineer. The seismic site specific soil classification shall be provided by the registered professional geotechnical engineer preparing the soil investigation report in accordance with ASCE 7-05. Unless indicated by special site considerations, evaluation of soil corrosivity is not required.

## 7.2 Construction Type

For circular submersible pump stations with wet well inside diameters less than 12 feet, precast, coated concrete pipe sections (conforming to fabrication and tolerance requirements of ASTM C478) may be used for caisson or conventional construction, instead of cast-in-place type concrete.

If the C-P standard precast concrete wet well with integral precast concrete valve vault detail is used, the Engineer is to design the integral valve vault for cantilever, with no support from the wet well below.

Wet wells shall incorporate an epoxy coating applied to the interior surface of the concrete, whether of precast or cast-in-place construction, in accordance with Section 822 of the C-P standards. Coating shall cover interior concrete surfaces of the wet well wall(s) and underside of the roof slab. Joints of precast sections shall be provided with a positive seal (see manholes in Conveyance Requirements). Construction joints of cast-in-place construction shall utilize a minimum 6-inch by 3/8-inch PVC waterstop. Detailing shall indicate a continuous seal.

## 7.3 Structural Design Criteria for Program Pump Stations

Structural designs shall be in accordance with the applicable codes and standards, including ACI 350.

Below-grade structures shall be designed to withstand external horizontal loads imposed by saturated lateral earth pressures with ground water at finished grade or at the 100-year flood elevation, whichever is higher, while empty, and internal hydrostatic loads while pump station is full of water with no external earth pressures. Lateral earth pressures shall provide for surcharge due to adjacent truck or crane loads. Where pump station consists of dual wet well compartments (cells), the common wall between the cells shall be designed for full hydrostatic load on one side while the other cell is empty.



The top slab of a submersible pump station shall support the dead load of the slab, plus a uniform live load of 250 per square foot (psf). The slab shall also support a concentrated live load at any location equal to the weight of the single largest submersible pump to be installed in the station. The facility design shall preclude vehicles from driving onto the top slab.

Other minimum uniform live loads are as follows:

Grating	150 psf
Stairs and Catwalks	150 psf
Electrical Control Rooms	200 psf or actual loads, whichever is greater

Wind (2006 IBC)

Basic wind speed (3 sec gust)	110 mph
Category	C
Importance Factor	I=1.15

Seismic (2006 IBC)

Occupancy Category	III
Importance Factor	I=1.25
$S_s$	=0.125g
$S_1$	=0.054g

## 7.4 Buoyancy

A buoyancy analysis shall be performed to determine if additional restraint is required to prevent wet well flotation when the wet well is dewatered. The buoyancy analysis shall follow the recommendations of ACI 350.4R, *Design Considerations for Environmental Engineering Concrete Structures*, and as noted herein. The pump station and all ancillary below grade structures shall be designed to resist buoyancy due to groundwater at finished grade or the 100-year flood elevation, whichever is higher. The use of flap (hydrostatic relief) valves in the walls or pressure relief valves in the floor slab will not be an acceptable approach. The weight of items such as mechanical and electrical equipment, water weight, baffle walls, fillets, grout fill, shall not be considered in resistance against buoyant forces, since these are either temporary or may change in the future.

Note that special precautions may be required to prevent the possibility of flotation during the construction of the wet well.

## 7.5 Access Hatches

Hatches shall be gasketed to prevent rainwater from entering the pump station and designed for a uniform load of 250 psf. The frame and cover plate shall be fabricated from extruded aluminum trough flange with continuous anchor flange around the perimeter and aluminum checker plate or be constructed of 316 stainless steel. All aluminum embedded in concrete shall be coated with a bituminous paint. The frame and cover plate shall be



equipped with all Type 316 stainless steel hardware and accessories, including lift assist mechanisms. Lifting mechanism shall consist of stainless steel compression lift springs enclosed in telescoping vertical housing or stainless steel torsion lift springs. The access hatch shall be provided with a hasp and recessed, keyed padlock locking system. Due to potential vandalism, a standard integral snap lock system shall not be used.

Pump access hatches (minimum 4 feet x 6 feet) shall be sized to provide standard or manufacturer's recommended clearance on all sides of the pump as it is being removed. Sizing and placement of the hatch shall be in accordance with the pump manufacturer's minimum recommendations and hatches shall be provided by the pump. Safety hatches shall be provided. Access hatches for maintenance of pumps and influent chamber shall be 4 feet wide x 6 feet long.

## 7.6 Handrails

Two-rail type handrails shall be provided where required by OSHA and shall be designed to sustain concentrated and uniform loads as prescribed in the IBC.

Aluminum handrails are acceptable. Carbon steel handrails are not acceptable, regardless of surface treatments they might receive.

## 7.7 Grating

Foot traffic grating shall be aluminum press-locked or swage-locked, rectangular, bar-type with manufacturer's standard slip resistant surface. I-bar type grating will not be acceptable. Seat angles or support beams shall be aluminum, except for supports embedded in concrete, which shall be Type 316 stainless steel.

Light and heavy vehicle traffic grating shall be galvanized steel heavy-welded or press-locked, rectangular, crossbar type. Seat angles or support beams shall be galvanized steel, except for supports embedded in concrete, which shall be Type 316 stainless steel.

## 7.8 Wet Well Specialties

- All guide rails, chains, anchor bolts, and other fasteners and hardware within the wet well shall be Type 316 stainless steel.
- No permanent ladders or rungs are to be installed. No handrails or intermediate landings are to be installed inside the wet well.



# 8. Architectural Requirements

---

## 8.1 Need for Electrical Building

Electrical buildings are generally not required for C-P standard duplex pump stations. An electrical building may be required for C-P standard triplex pump stations with variable frequency drive (VFDs), depending on the horsepower of the motors. In this case, a special detail has been developed for the electrical building, which can be obtained from the PM at the request of the Engineer.

An electrical building is required to house motor control centers (MCCs), VFDs, and instrumentation and control systems for Program pump stations and large capacity pump stations. An electrical building may also be required if the station design includes an electrical MCC or instrumentation microprocessor for telemetry, depending upon the size of the pump station.

See below for electrical building requirements.

## 8.2 General Building Considerations

- Exterior treatment will be based upon neighboring site conditions and aesthetics to enhance the pump station/electrical building appearance.
- Housekeeping pads (6 inch minimum) shall be placed under all floor mounted equipment.
- Materials of wall construction shall be concrete or masonry.
- Pre-engineered metal building construction is not permitted.
- Consider security and safety in the selection of materials and in the design features of the building.
- Buildings shall meet the requirements of the Louisiana Energy Code.
- Minimum interior height clearance of control building shall be 10 feet.
- Windows are not allowed.
- Gutters and downspouts are not allowed.

## 8.3 Wall Construction

Wall construction shall be masonry bearing wall construction. Masonry may be decorative CMU, brick veneer on CMU back up, or brick/block cavity wall construction. Cast-in-place or precast concrete is allowed only where buildings do not require insulated walls. Concrete walls shall be aesthetically enhanced by use of rustication or formliners.



## 8.4 Roof Structure and Roofing Materials

All roofs shall have a minimum positive slope of ½ inch per foot for drainage to roof drains or roof scuppers. Gutters and downspouts are not allowed.

Roof penetrations shall be minimized or eliminated, where possible.

Roof construction shall be one of the following types:

- Metal deck on structural beams.
- Metal deck on steel bar joist.
- Steel roof truss.
- Light-gauge steel truss.
- Pre-cast concrete hollow core slabs
- Pre-engineered wood truss.

Roofing materials shall be rated for minimum UL I-90 wind uplift and use one of the following, as appropriate, for the roof structure construction:

- Standing seam metal roof (preferred by C-P)
- 40-year architectural grade asphalt shingles (if approved by C-P).
- Fully adhered or mechanically attached elastomeric single-ply membrane (if approved by C-P).

## 8.5 Energy and Insulation

Building shall be cooled only and not heated. Exposed insulation is not permitted.

## 8.6 Finishes

Exterior walls shall be coated with water repellent and sacrificial anti-graffiti coating.

Exterior eave overhangs shall be constructed of low maintenance materials such as metal soffit panels.

Interior wall surfaces shall be painted with semi gloss enamel for increased light reflectance.

## 8.7 Security

All louver openings shall be covered with anti-burglar bars.

Windows are not allowed. Doors shall not have any installed windows or panels.

## 8.8 Building Access

### 8.8.1 Doors and Hardware

Personnel doors and frames shall be of hot dip galvanized steel construction. Where security is a concern, stainless steel frames and doors shall be used.



For access to electrical buildings or rooms for the installation or removal of MCCs or control panels, doors shall be hot dip galvanized steel overhead coiling doors of sufficient height for equipment to pass through vertically.

Access doors shall meet the requirements of the IBC. All hardware shall meet BHMA standards.

Hinges shall be ball bearing, extra heavy weight, stainless steel finish, meeting BHMA 156.1 standards. Exterior hinges shall include a non-removable pin.

Locks and latches shall be lever-handled, mortise locks meeting BHMA 156.13, series 1000, grade 1 with stainless steel lock case and finish and non-ferrous or corrosion resistant working parts.

All active leaves of doors shall be equipped with closers. Exterior doors shall be equipped with door stops. Provide hold-open devices at doors used for moving equipment.

All exterior doors shall be fully weather-stripped and provided with thresholds.

### **8.8.2 Louvers**

All louvers shall be factory finished, storm-proof, aluminum construction. Where operating louvers are required, a combination-type louver is recommended.

## **8.9 Confined Space Entry**

All designs shall consider the provisions stipulated within OSHA and other regulatory agency requirements to protect operational and maintenance personnel from potential hazards in pump stations. In general, wet wells will not be regularly entered by maintenance personnel.





# 9. Mechanical Requirements

---

## 9.1 Piping Clearances

The minimum acceptable vertical distance from any walking surface to the bottom of any pipe, slab, beam, or other overhead obstruction is 7'-0". Vaults, if required, shall have enough depth for air release valve(s) to fit on top of the discharge header and beneath the top slab or hatch with at least 6 inches of clearance.

The minimum acceptable spacing between the outside of piping joints and walls in valve vaults is 24 inches, measured from the outside of the widest pipe fitting or valve, typically a check valve.

The minimum acceptable clearance between a floor and the deepest pipe fitting or valve is 12 inches.

The minimum acceptable spacing between discharge pipes is typically determined by the required spacing between the pumps or the pump hatches, with a minimum 3'-6" clearance. The minimum distance between hatch openings is 12 inches.

## 9.2 Pump Spacing

All pump spacing and related clearances shall be in accordance with manufacturer's recommendations and Hydraulic Institute standards for proper pump operation.

## 9.3 Pump Selection

All submersible pumps shall be able to "run dry," that is, with liquid in the wet well only deep enough to submerge the bottom half of the pump's volute. Sufficient electrical/control cable shall be attached to the pump such that no splicing is required between the pump and a junction box. A seal shall be supplied between a junction box and any panel or disconnect. An air gap shall be provided between the wet well and junction box or a portion of the junction box shall be vented to isolate the junction box from the moisture and corrosive gases in the wet well. A C-P standard detail has been developed for the junction box. A detail for the Program pump station junction boxes has been included in Attachment C.

Selected pump impeller diameters shall be in the middle range of the available diameters for the selected pump. Maximum or minimum impellers are not allowed.

If a pump is to operate with a variable speed drive, the design point flow shall be located at about 120 percent of the peak efficiency flow.

The Baton Rouge Qualified Products List (QPL) includes five approved pump manufacturers. The Engineer shall utilize the QPL-approved manufacturers for pump selection unless only one pump manufacturer on the QPL can provide an acceptable pump, at which time the Engineer shall determine other acceptable manufacturers.



## 9.4 Pump Motor Selection Criteria

Submersible, explosion proof motors shall be provided for all submersible pumps. TEFC motors or submersible, explosion proof motors shall be provided for dry pit pumps. Motor horsepower for submersible pumps for pump stations shall be 5 to 500 hp. Motor size shall be such that the nominal horsepower rating is not exceeded over the full operating range of the pump (i.e. motors shall be non-overloading at all points on the pump curve, exclusive of the service factor).

Submersible pump manufacturers use different approaches to define the service factor of motors at rated head conditions. Each manufacturer also rates horsepower at different temperatures and at different locations of where the amperage draw is measured (at the starter or at the motor terminal input leads). The minimum acceptable service factor on constant speed motors is 1.15, and minimum acceptable insulation is Class F. Motors are not to be oversized to reach the 1.15 service factor. The service factor for inverter duty rated motors shall be 1.0 with the nameplate indicating that the motor meets the standards of NEMA MG1, Part 31.

The Engineer shall determine the motor horsepower based upon the manufacturers on the QPL who can provide an acceptable pump. If the horsepower range between pump manufacturers is greater than 10 percent, then the Engineer may inform a manufacturer that their pump selection is not acceptable due to horsepower. The Engineer shall list a maximum allowed horsepower for each pump in the pump specifications for a Program pump station or on Sheet 805-02, Sheet 2 of 2 or 805-03, Sheet 2 of 2 for a C-P standard pump station. The maximum allowed horsepower shall be used to determine generator sizing. Motors for use with variable speed drives shall be inverter duty rated motors. Motors from 5 to 500 hp shall be 480 V, 3-phase, 60 Hz. Smaller pump motors may be 240 V, 3-phase, 60 Hz. The Engineer shall coordinate with the electric utility company to determine what voltages are available at a given site at which the pump station is being installed or modified. In addition, the Engineer shall coordinate with the local electric utility to determine if the local power grid can support across-the-line pump starting or if the grid requires some type of current-limiting starting method.

Following the preliminary pump size selection, the local Electrical Utility shall be contacted to coordinate electrical service for the pump station. If 480 V, 3-phase, 60 Hz is not available at the pump station site or if the Utility assesses a fee to provide electrical service to the pump station, the Engineer shall do the following:

1. Inform the PM
2. Determine by working with the electric utility a) the nearest 480 volt (V) source, b) the cost to the C-P to bring 480 V service to the site, and c) the location and cost to bring 240 V, 3-phase, 60 Hz service to the site.

If the connected load is less than or equal to 100 hp, the C-P and the PM may allow 240 V, 3-phase service and motors. Single phase motors are not allowed.



## 9.5 Pump Removal Systems

Only Type 316 stainless steel link chain shall be used to lift submersible pumps out of wet wells.

Pump stations with large submersible pumps that exceed the weight capacity of the C-P's portable lifting equipment (10 tons) will require permanent hoisting systems for pump removal and replacement. The Engineer shall consult with the Project Manager regarding approved systems for pump removal and handling. Pump/motor combinations that weigh more than 10 tons shall have permanently installed bridge cranes for equipment removal, meeting the requirements stated below.

## 9.6 Pump Guide System

Dual Type 316 stainless steel guide rail systems shall be used for guiding submersible pumps to/from their anchorage/hydraulic connection points.

Guide rail supports shall be installed not more than 20 feet on center, with 10 feet preferred, all in accordance with the manufacturer's recommendations. Guide rails and supports shall be Type 316 stainless steel. Non-sparking components shall be specified for discharge connections.

## 9.7 Piping Selection and Arrangement

For C-P standard pump stations, the pump station layout and piping arrangement shall be in accordance with the C-P Standard Details. For Program pumping stations, the pump station discharge piping, including check valves with hydraulic cushion and closing speed control, isolation non-lubricated eccentric plug valves, and header piping shall all be located abovegrade as shown in Attachment B. A dual header shall be provided to include two flow meters (one on each header), with plug valves isolating the flow meters.

The station piping, valve, and flow meter support slab, as shown in Attachment B for Program Pump Stations, shall have a valved gravity drain line piped to the wet well above the high water elevation, depending on specific site conditions.

Wet well, valve vault, and other site piping shall be ductile iron up to the point of tie-in to the forcemain. All buried piping shall be mechanically restrained. All non-buried piping shall be hard flanged with flange coupling adaptors with thrust-rod tie elements for ease in piping installation and removal. Use fabricated hot-dip galvanized steel pipe saddle or concrete assemblies for support and thrust restraint of exposed pipes and valves that are not in the wet well. For support and thrust restraints in the wet well, Type 316 stainless steel shall be used. Do not use concrete support or thrust blocks within valve vaults.

Wall penetrations shall be flexible, watertight connections that allow differential settlement of the pipe and structure wall to take place without damage.

All station piping shall be epoxy ceramic-lined ductile iron, which shall have a minimum pressure rating of 150 pounds per square inch (psi). High pressure rating may be required when considering operating and surge pressures and maximum pump shutoff head.



Water piping following the backflow preventer shall be marked “non-potable” and painted yellow, per the C-P standard plans, Sheet 805-04. Backflow preventers and yard hydrants shall follow the detail on Sheet 805-04.

Pump station influent gravity sewer piping, yard piping, station piping, and forcemain piping shall be in accordance with the Program *Conveyance Design Requirements*.

## 9.8 Valve/Gate Selection

Isolation valves shall be bolted directly to the flange connections on headers.

Full port eccentric plug valves (non-lubricated) with elastomeric-coated plug and geared handwheel operators are to be used for isolation purposes. Lubricated plug valves with metal seats are unacceptable. Eccentric plug shaft shall be installed horizontally, with plug stored in the top position when valve is OPEN, to minimize potential for grit accumulation in valve seat or shaft bearing. Valves shall be laid such that the plug is on the “top” of the body when fully opened.

Gate valves shall be used for isolation  $\leq 10$  inches in size.

Double-disk gate valves, knife gates, and “coplastic” gates are not acceptable, unless approved by the PM.

Chain wheel operators shall be provided for all valves mounted with centerlines more than 6 feet above the operating floor.

Only full-body flanged check valves shall be used. Wafer body valves and ball-type valves are not acceptable. Cushioned swing-type check valves with an outside lever and spring or weight unit shall be provided on Program pump stations, so operators can see which valves are OPEN. Hydraulically-operated pump control valves may be utilized under special circumstances. Flow velocities through check valves shall not exceed 10 fps, and the valve closure shall be hydraulically dampened with three speed controls to mitigate high surge pressures associated with pump shutdown. Check valves shall be mounted at elevations that permit servicing from the floor without scaffolds or ladders.

A position switch shall be provided on each pump check valve to indicate when the valve is in the OPEN position. The pump controls shall monitor the check valve position switch when the pump is called to operate. If the check valve is not detected to be OPEN after a preset time delay, the logic will consider that there is no pump flow and the logic will shut down and alarm the pump. Refer to Drawing E-3 in Attachment C for specific relay logic used in the example.

Sewage-type combination vacuum/air-release valves with stainless steel trim shall be installed on the discharge piping for C-P standard pump stations. If the valve will not fit in the valve vault, a separate vault in the yard piping of the station shall be provided for the combination vacuum/air release valve.

Sewage-type combination vacuum/air-release valves with stainless steel trim shall be installed on single pump piping for Program pump stations immediately adjacent to the check valve inlet on a branch of a tee. The valves shall be provided on the discharge of each pump. The valves shall be tapped into a blind flange on a tee. The valve exhaust line shall



discharge back to the pump station wet well, above the maximum water surface elevation. Provide an eccentric plug or gate isolation valve on the vertical piping upstream of each combination vacuum/air release valve.

Combination air-vacuum relief valves shall be provided at all high points within the pump station and on the site. Valves shall be of the type typically used on wastewater applications per DPW standard air release valve (ARV) short body. Provide an eccentric plug isolation valve under each combination air-vacuum relief valve.

All valves shall have a minimum pressure rating of 150 psi, and valve design and selection shall take into consideration operating and surge pressures and maximum pump shutoff head.

Isolation gates in the wet well shall be fabricated Type 316 stainless gates conforming to AWWA C561.

Electric operators shall be provided for valves 20 inches and larger and gates having four square feet or more of surface area. The operators shall include local OPEN/CLOSED controls that can be secured to prevent unauthorized operation of the valve. The operators shall include OPENED and CLOSED limit switches that shall be monitored via the Station control system. The preferred manufacturer for electric operators is Limitorque.

## 9.9 Backflow Preventer

For Program pump stations, a reduced-pressure principle backflow preventer per C-P Standard Details for the required water supply source shall be located adjacent to the water meter with a minimum of one 1-1/2 inch diameter hose bibb on the exterior, supported by a pipe bollard, and 1-1/2 inch hose bibbs located onsite as necessary for pump wash down and wet well wash down. The backflow preventer shall be located on the water supply immediately as the line arrives onsite, and shall be mounted abovegrade in an appropriate, DPW-approved standard enclosure. The area shall be appropriately landscaped. Note that backflow preventers have a drain that operates periodically – this shall be taken into account in the design. The Engineer shall verify that adequate potable water pressure exists at the site, and that the need for potable water booster pumps is not required.

## 9.10 Provisions for Bypassing

For Program and large capacity pump stations, an abovegrade flanged connection, force main size, shall be provided to receive a DPW-supplied header. It shall be located downstream of the individual pump isolation valves to permit connection of a dewatering pump discharge during wet well maintenance. This will allow temporary pumps to be located in the influent chamber and to discharge to the forcemain so the pump station can be taken out of service.

For C-P standard pump stations, C-P Standard Details include a connection in the valve vault on the discharge of the pump station for bypassing purposes. An immediate upstream manhole or chamber on the influent sewer, within 30 feet of the wet well, shall also be provided to serve as the dewatering pump suction well.



## 9.11 Odor Control

The need for odor control will be identified in the Project Definition. The Engineer shall design biotowers for odor control for all pump stations where odor control is required, except those that pump only wet weather peak flows. Since biotowers need continuous operation, carbon canisters shall be used for pump stations that only pump peak wet weather flow. Wet wells shall have a minimum of six air changes per hour. At least two fans shall be installed. One or more towers shall be provided. Odor control scrubber connections shall be based upon site-specific requirements and condition.

For biotowers with a recirculation system, an air gap shall be provided per the detail entitled "Odor Control System Piping Detail" shown below. The air gap must be provided to meet the requirements of the Louisiana Department of Health and Hospitals. For biotowers without a recirculation system, the air gap is not required (see figure *Odor Control System Piping Detail* below).

Those pump stations that are in service on a continuous basis shall use biotower technology.

### Design Criteria

- Minimum Empty Bed Contact Time (EBCT) – 15 seconds
- Hydrogen sulfide (H<sub>2</sub>S) inlet design conditions
  - Average concentration 10 parts per million on a volume basis (ppmv)
  - Maximum concentration 200 ppmv
- Removal efficiency – 99 percent minimum

Those pump stations that are to be used for wet weather flow events only shall use activated carbon technology.

### Design Criteria

- Maximum superficial velocity – 55 feet per minute (fpm)
- H<sub>2</sub>S inlet conditions
  - Average concentration 10 ppmv
  - Maximum concentration 200 ppmv
- Removal efficiency – 99 percent minimum

Note: At some sites with more than one station, one of the stations may operate continuously while the other(s) only operates in wet weather conditions. In this case, biotower technology may be used for both stations.

### Odor Ducts

- Fiberglass (FRP) shall be used abovegrade.
- Penetrations through concrete shall be Type 316 stainless steel
- Buried duct work shall be high density polyethylene (HDPE) and shall have drainage provisions

### Fans

Fans shall be FRP construction with constant speed motors (TEFC).

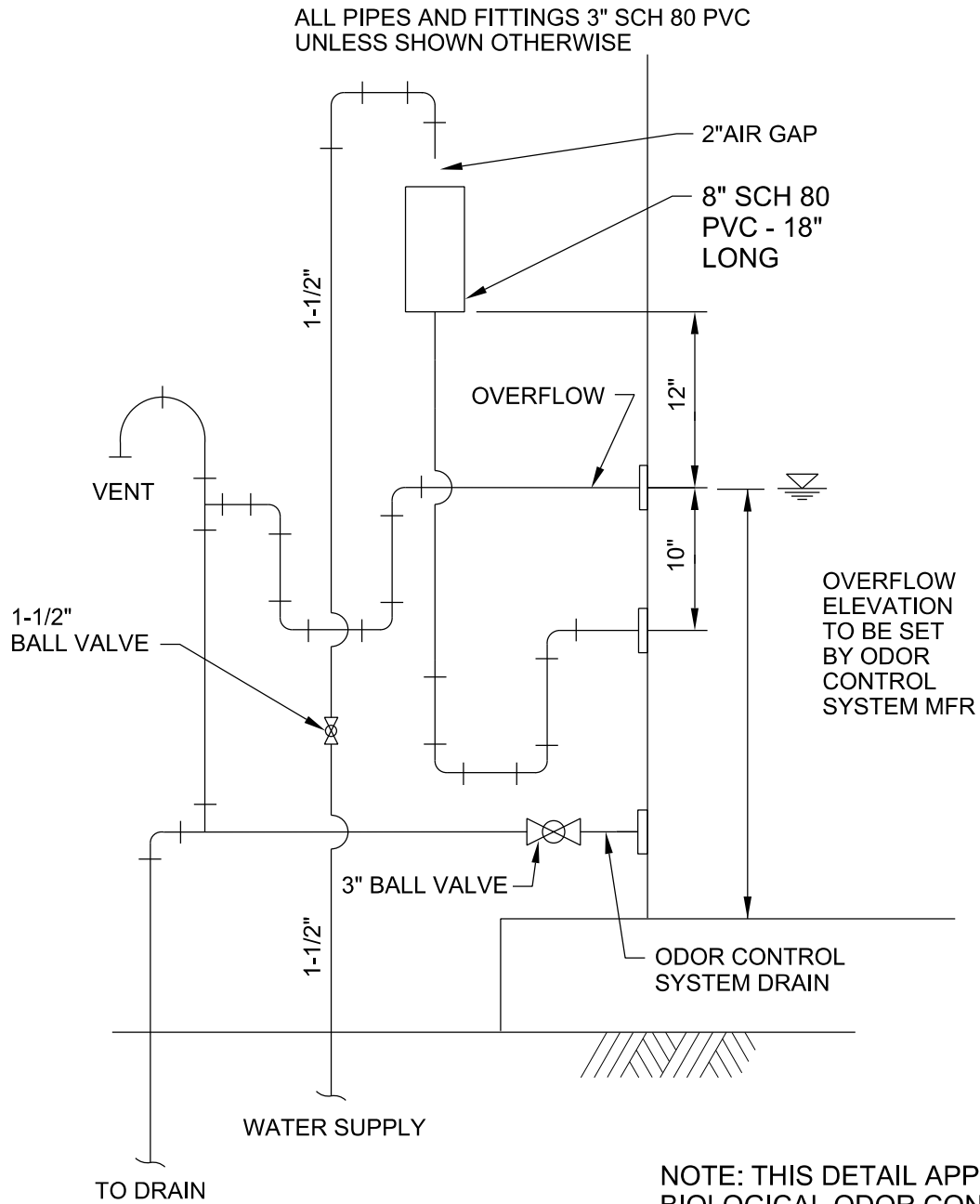

NOTE: THIS DETAIL APPLIES TO BIOLOGICAL ODOR CONTROL SYSTEMS WITH RECIRCULATION PUMPS

# ODOR CONTROL SYSTEM PIPING DETAIL

NTS

© CH2M HILL  
NOTE TO DESIGNER:

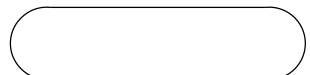

DATE  
TDC  
TDR  
LCT



## 9.12 Pigging Facilities

Pigging facilities will not be provided at pump stations for launching pipe pigs; however, the pump station's bypass connection shall be arranged to allow the connection of a pig launcher. If this is not feasible, buried and plugged branches shall be provided so that these facilities can be installed in the future.

## 9.13 Pipe Finishes

Exposed interior and exterior piping shall be painted with an industrial-grade alkyd enamel with a primer coat, plus two finish coats per DPW standards.

Piping and pumps in wet wells shall be coated with high solids content epoxy per DPW standards.

## 9.14 Pump Station Layout

Attachment B includes two drawings for a typical Program pump station.



# 10. Ventilating and Air Conditioning Requirements

---

## 10.1 Design Standards

Ventilating and air conditioning (A/C) systems shall be designed in accordance with all codes. Ventilation with odor control shall be provided for wet wells where specifically required by the Project Manager. Cooling loads shall be calculated using ASHRAE methods. Ventilation systems shall be coordinated with odor control systems where both are used.

## 10.2 Area Classifications

Wet wells shall be classified as Class I, Division I, Group D areas, unless modified by ventilation, per NFPA 820. Electrical and control buildings and valve and meter vault spaces shall be located in non-classified areas per NFPA 820.

## 10.3 Motor Control Housing

MCC and instrumentation shall be housed in a separate air-conditioned electrical/control building. Field-mounted exterior panels may be used only for C-P standard pump stations. If VFDs are allowed in a field-mounted panel, the panel shall be air-conditioned.

## 10.4 Air Conditioning

Heating shall not be provided. Heat pumps are not allowed.

Any control building shall be equipped with moisture and condensation control; however, humidity levels shall not be specifically controlled in the building. The preferred design is a properly sized unit(s) (minimum two units at 50 percent capacity each) that runs continuously to keep the air moving and to provide adequate level of dehumidification through the cooling cycles. The heating, ventilating, and air conditioning (HVAC) units shall be wall mounted package units, if possible. Large units, if required, shall have an indoor evaporator and outdoor condenser mounted at grade level. Window units are not acceptable. Portions of the unit that contact high humidity and potentially corrosive atmospheres shall be coated with corrosion-resistant material. The protective coating shall be factory-applied and provided by the unit manufacturer.

## 10.5 Ventilation and Air Conditioning

Specific ventilation requirements are as follows:

- The Engineer shall investigate both active and passive ventilation systems.
- Ventilation in a non-odor controlled wet well will be provided by a C-P supplied portable fan, during maintenance operations.



- The electrical control building/ room, if provided, shall be air conditioned only, not ventilated. The A/C unit shall provide a minimum of 50 cubic feet per minute (cfm) of outside (make-up) air. The A/C unit shall be wall mounted and designed to reject all heat loads from electrical equipment in the building and heat gained from the walls and roof.
- The maximum temperature setpoint shall be 80 degrees F.
- Roof mounted units are not acceptable.
- Exterior panels shall be Type 316 stainless steel.
- All ventilation fans shall be made of corrosion resistant materials and shall be explosion-proof in classified areas.
- Pressure drop through louvers shall not exceed 0.1 inch at an air flow velocity of 750 fpm.
- Ductwork in passive ventilation systems shall be designed for velocities less than 600 fpm.

# 11. Electrical Requirements

---

## 11.1 General

The electrical design for power distribution to the individual pump stations will be undertaken by the serving electrical utility, under a separate contract, and not addressed in these design requirements. However, issues of coordination with the serving utility are addressed.

The pump stations have areas classified under NFPA 820, Standard for Fire Protection in Wastewater Treatment and Collection Facilities, and NFPA 70, National Electric Code, as Class 1, Division 1 and Class 1, Division 2 hazardous areas and unclassified areas. All materials and electrical design applications shall meet the requirements of the area classification in which it is installed.

The typical pump station, from an electrical load perspective, consists of electrical service, power distribution, standby generation and automatic load transfer, pump controls, pumps, wet well level monitoring, ventilation and odor control fans, electrical protection components, and lighting. The electrical design requirements for pump stations include the following elements:

- Electrical Service Equipment
- Power Distribution Equipment
- Branch Circuits
- Motor Control Equipment
- Conduit System
- Conductors
- Junction Boxes and Enclosures
- Lighting
- Grounding
- Transient Voltage Surge Suppression

Primary criteria for the design of the electrical system are that it is safe, meets capacity requirements, is reliable, provides desirable operational control and ease of maintenance, and is economically reasonable. The following sections are a discussion of the individual electrical system elements as it relates to the aforementioned primary design requirements.

## 11.2 Codes

- National Electrical Code 2011 Edition
- National Fire Protection Association 820
- ANSI/IEEE Standard 141 for Motor Control Equipment
- IEEE Standard 142 for Grounding
- IEEE C62 for application of Transient Voltage Surge Suppression
- National Safety Fire Protection Code



## 11.3 Electrical Service Equipment

The local electrical utility, as discussed above, shall provide electric service at 480 V, 3-phase for pump stations with pumps from 5 hp to 500 hp. If 480 V, 3-phase power is not available, 240 V, 3-phase may be used for converted loads of 100 hp or less. There may be cases where only single phase power is available. In these cases, phase converters or a new 3-phase service will be required. While 3-phase power is preferred, DPW shall decide which option, 3-phase power or phase converters, is to be used. Cost estimates for bringing 3-phase power to the pump station shall be received from the electrical utility to assist DPW in their decision making. The electrical engineer shall be responsible for coordination of all pump station power requirements with the serving electrical utility and obtain the associated approvals and cost estimates. The program has arranged dedicated points of contact with each electric utility, each of them are familiar with the program and have been charged with providing support.

It is anticipated that the utility will distribute power to pump stations with an underground service lateral to the electrical service equipment provided under these projects. The electrical service equipment shall consist of a utility conductor landing section, metering section, and a main breaker. All of these devices will be designed based on the serving utility's service requirements.

## 11.4 Electrical Design, Power Distribution, and Motor Control Requirements

### 11.4.1 C-P Standard Pump Stations

C-P standard pump stations include pump stations with two pumps (duplex) and three pumps (triplex). Duplex pump stations are smaller pump stations that include one duty and one stand by pump. Duplex and triplex stations are defined as Type I and Type II pump stations in Section 805 of the DPW standard specifications.

#### Type I Pump Stations

Type I pump stations include both duplex and triplex pump stations with the electrical and controls equipment in a field-mounted panel, including VFDs, if specified.

Duplex pump stations are generally 75 hp or smaller and are typically constant speed, unless VFDs are needed for hydraulic reasons. Duplex stations with pumps 50 hp or greater shall utilize a reduced voltage soft starter (RVSS), rather than a full voltage, non-reversing starter (FVNR). Sheet 805-09, Sheet 2 of 2 shall note whether or not the starter is FVNR or RVSS.

Triples Type I pump stations are generally less than 75 hp per pump and have VFDs. The DPW Engineering Division has prepared a set of standard drawings and specifications that show electrical design requirements for Type I pump stations. The Engineer shall follow these requirements for detailed design of Type I pump stations. The following drawings shall be followed for electrical design:

Standard Drawing #	Title
805-01	Concrete Duplex Station with Integral Valve Box Details – 2 sheets
805-02	Concrete Duplex Station Details – 2 sheets
805-03	Concrete Triplex Station Details – 2 sheets



Standard Drawing #	Title
805-04	Miscellaneous Pump Station Details (Type I and Type II) – 2 sheets
805-05	Miscellaneous Electrical Details (Type I and Type II)
805-06	VFD Control Wiring Diagram (Type I and Type II)
805-07	Pedestal Mount Control Panel Details (Type I) – 2 sheets
805-08	Power Distribution and Pump Control Diagram (Type I)
805-09	Three Line Power Diagram (Type I) – 2 sheets
805-10	PLC Power Distribution (Type I)
805-11	PLC Slot 1 Detail (Type I) – 2 sheets

The Engineer shall obtain copies of the standard drawings listed above for use in electrical design of the duplex pump stations. For triplex stations with a field-mounted panel, standard drawings include VFDs and automatic transfer switch (ATS) incorporated into the panel. In sizing the generator and other electrical equipment, the Engineer shall use the maximum allowable pump motor horsepower as the basis, per the process mechanical Engineer.

The Engineer is responsible for final design and stamping of Sheet 805-09, Sheet 2 of 2.

Note that all equipment shown on these drawings are furnished and installed by the contractor except the generator and Supervisory Control and Data Acquisition (SCADA) cellular modem/antenna, which are Owner-furnished equipment. ATS shall be sized by the Engineer and furnished by the contractor.

### Type II Pump Stations

Type II pump stations include triplex pump stations with variable speed pumping in an electrical building. Triplex stations include two duty pumps and one standby pump, with motor horsepower up to 300 hp. Type II stations shall also be designed in accordance with C-P standard drawings and specifications. The following drawings shall be followed for electrical design:

Standard Drawing #	Title
805-03	Concrete Triplex Station Details
805-04	Miscellaneous Pump Station Details (Type I and Type II) – 2 sheets
805-05	Miscellaneous Electrical Details (Type I and Type II)
805-06	VFD Control Wiring Diagram (Type I and Type II)
805-12	Control Panel (Type II) – 2 sheets
805-13	Power Distribution and Pump Control Diagram (Type II) – 2 sheets
805-14	Three Line Power Diagram (Type II) – 2 sheets
805-15	PLC Slot 1 Detail (Type II)
805-16	PLC Slot 2 Detail (Type II)
805-17	PLC Slot 3 Detail (Type II)



Standard Drawing 805-14 provides a three-line diagram for a triplex pump station with an electrical building. The primary requirements for the Type II pump station electrical design are:

- An appropriately sized standby generator will be purchased by the C-P and provided to the contractor as owner-furnished equipment. All other electrical equipment including the automatic transfer switch shall be furnished and installed by the contractor and included in the Engineer's design. An automatic transfer switch can be integrated with the motor control center described below, or can be separate stand-alone equipment.
- In sizing the generator and other electrical equipment, the Engineer shall use the maximum allowable pump motor horsepower as the basis, per the process mechanical Engineer.
- Design shall include a power distribution panel (PDP) as shown on drawing 805-14. The PDP shall include appropriately sized feeder breakers for the VFDs, power panel and lighting panels, and combination starters for other miscellaneous pumps or fans as required for each pump station. Lighting and power panels shall include circuits required for the stand by generator miscellaneous loads and other facility loads. Coordinate with generator supplier for requirements.
- Coordinate with utility for a utility transformer size required to meet the pump station loads per the Engineer's design. The Engineer will finalize generator size based on selected pump horsepower. Examples of typical ATS ratings, utility transformer ratings, and bus ratings are provided in Table II shown on drawing E-2 (Attachment C).
- The Engineer is responsible for final design and stamping of 805-14, Sheet 2 of 2.
- VFDs that are above 150 hp shall be free standing, 18 pulse, pulse width modulation (PWM) type drives. Specifications shall require meeting individual and total current and voltage harmonic distortion limits in accordance with IEEE 519-1992 at the MCC bus, when all duty pumps are running at full load for both utility and standby generator operation.
- Design VFD control diagram based on standard drawing 805-06.
- The preferred manufacturers for switchgear are Allen Bradley, Tesco, General Electric, and Square D. The preferred manufacturers for VFDs are Allen Bradley and Toshiba.
- A special detail has been developed and shall be used for electrical buildings for Type II stations. The special detail is available in AutoCAD format from the PM at the request of the Engineer.
- Standard drawings 805-12, 805-13, and 805-15 through 805-17, show control panel/PLC wiring. Coordinate all signal interfaces with the control panel design. See Section 12 in this document for more information on instrumentation and control design.

## 11.4.2 Program Pump Stations

Program pump stations include pump stations with four, six, or eight pumps. These stations are Type III stations as defined in Section 805 of the DPW standard specifications.



- Example drawings I-1 through I-8, showing control panel/PLC wiring, are included in Attachment D. Coordinate all signal interfaces with the control panel design.

For pump stations with an electrical service rated for 800 amps or less, an ATS shall be utilized, rather than a main-tie-main arrangement. Drawing E-1 (Attachment C) provides an example one line diagram for a four pump station with an ATS. These types of pump stations are identified as "Type IIIA" on Drawing E-1 (Attachment C).

Drawing E-2 (Attachment C) provides an example of electrical design requirements for Program pump stations that include four or more pumps with a main service rating greater than 800 amps. These types of pump stations are identified as "Type IIIB" on Drawing E-2 (Attachment C). For pump stations with four or more 200 hp or larger pumps, a 480 V switch board with main, tie, and generator breaker with automatic transfer control (ATC) is a requirement. Provide hard wired electrical interlocks to prevent simultaneous closing of generator and utility breakers if the tie breaker is closed. The switchboard shall include feeder breakers for the VFDs and a small MCC. The MCC will include starters for other miscellaneous fans and pumps required for the pump station, per the Engineer's design.

Other requirements are similar to those described above for the Type II pump stations. An appropriately sized standby generator will be furnished by the Owner for installation by the contractor. All other electrical equipment is furnished and installed by the contractor.

The Engineer is responsible for preparing complete contract documents including all drawings and specifications.

Program pump stations shall be designed to match the inflow hydrograph. The minimum speed shall generally be 70 percent of the full speed, depending upon the static head of the pump station/forcemain system. The selection of VFDs shall take into consideration harmonic distortion limitations set forth in IEEE 519.

## 11.5 Branch Circuits

The load on branch circuits that supply lighting and receptacles, where applicable, shall be limited to 80 percent of the rating of the branch circuit protective device, per Article 220-3 of the National Electrical Code (NEC), because lighting and receptacle loads shall be considered "continuous." Branch circuit breakers for instruments, instrumentation panels, and other accessories, where the exact load is unknown but small, shall be sized at 15 amps to allow installation of multiple conductors to be installed in the same conduit without the need for de-rating. In addition, these circuits may pass through an instrument panel and become No. 14 AWG (American wire gauge) control conductors.

A separate branch circuit shall be provided for each instrument and instrumentation panel. Branch circuits and branch circuit protective devices shall be rated at 15 amps unless a larger size is required to supply the load. The design shall make an effort to group circuits that perform a common function together within a panelboard (i.e., all lighting together, all receptacles together). In addition, three- and four-wire branch circuits shall be used wherever they are appropriate to minimize the amount of conduit that is required. These circuits shall be connected to adjacent circuit breakers in the panelboard. Where a common neutral is used for multi-wire branch circuits, the neutral size shall be increased to account for third-harmonic neutral current generated by non-linear loads such as computers and



other similar devices. Extra space and spare breakers shall be provided in all 208/120 V panelboards.

A 110 V branch circuit shall be provided at each pump station for a convenience receptacle located in pump station control panel and in appropriate areas of the electrical building to help facilitate maintenance. Area classification shall be considered in locating convenience receptacles. Ground fault interruption shall be provided for all outlets at a pump station.

Branch circuits for pump power, controls, and alarm circuits entering the wet well shall be designed to provide strain relief for conductors suspended in the wet well and provide a demarcation box outside the wet well for transition to conductors suitable for the wet well environment. The demarcation box shall be located outside the wet well and associated hazardous classified areas. The example drawings provide detail of the preferred demarcation box and method of applying sealing fittings. Appropriate sealing fitting shall be used between the demarcation box and any panel.

Pump stations with four or more pumps of 200 hp or more shall have dual feed with tie-breakers with the loads equally divided between each half of the line-up.

## 11.6 Conduit System

Because of the small number of devices and loads and physical nature expected at pump station sites, the raceway to be utilized on program pump stations shall be a conduit system. Conduit material shall be selected based on the environment and application in which it is installed. Underground conduits shall be direct buried PVC-coated galvanized rigid steel (GRS). PVC-coated GRS shall be used for all conduits embedded in structural slabs, installed under structural slabs, in vertical penetrations of earth or concrete slabs, Class 1, Division 1 areas, Class 1, Division 2 areas, and for all underground conduit between facilities and structures. No other material shall be used for underground conduit applications with the exception of underground conduit for the electric utility service lateral, which shall meet the respective utility's specification for the application. Above ground conduits shall be PVC-coated GRS (classified area) or rigid aluminum conduit. The connection to field devices and motor shall be made with the use of liquid-tight flexible non-metallic conduit or liquid-tight flexible metal conduit (flex) with the lengths limited to 3 feet. Conduit material and associated fittings shall be applicable to the area classification in which it is installed. No other conduit types will be allowed.

Associated support of exposed conduit systems shall be Type 316-stainless steel for aluminum rigid and PVC-coated GRS conduits. Underground duct banks shall use nonmetallic duct bank spacers for multiple conduit installations. Install at intervals not greater than that specified in NFPA 70 for support of the type conduit used, but in no case should intervals be greater than 10 feet. Provide expansion fittings that allow a minimum of 4 inches of movement in vertical conduit runs from underground, where exposed conduit will be fastened to or will enter building or structure. Provide deflectional/expansion fittings in conduit runs that exit building or structure belowgrade. Specify the installation of ductbank warning tape approximately 12 inches above underground raceways. Align parallel to, and within 12 inches of, centerline of runs.

In the pump station site area, conduits shall be routed exposed or under slabs wherever possible. Embedded conduits shall be limited to small sizes (typically 1-1/2 inch or smaller)





and only used when absolutely necessary. Layout of any embedded conduits shall be coordinated with the structural engineer. Articles 345, 346, 347, 348, 351, and 501 of the NEC contain additional information pertaining to the installation of conduit systems and shall be consulted during design. All ductbank systems shall be designed with 20-percent spare conduit capacity sized similarly to other conduits which make up the same ductbank system.

## 11.7 Conductors

The minimum size power and control conductor shall be No.14 AWG. No.12 AWG conductors shall be used for long circuits where voltage drop is a concern. The minimum conductor size for lighting and receptacle circuits will be No. 12 AWG. All conductors shall be stranded copper conductors for all circuits except for lighting circuits, where solid or stranded conductors may be used. The conductors shall be PVC insulated and have a nylon jacket per UL type THWN/THHN/MTW. Where multiple control conductors are required between two devices, panels, or terminal junction boxes, a multi-conductor control cable can be utilized. Multi-conductor controls cables shall be constructed using UL type THWN/THHN/MTW single conductors bound together in a single assembly with a PVC jacket. The assembly shall be manufactured in accordance with UL 1277.

One hundred twenty (120) V control conductors may be installed with motor branch circuit conductors where control devices are located at or near the motor. Individual conductors shall be installed with branch circuit conductors No. 4 AWG and smaller, and multi-conductor cables shall be installed where the branch circuit conductors are No. 2 AWG or larger. Where the branch circuit conductors are larger than No. 4/0 or parallel conductors are used, control conductors shall be installed in a separate raceway.

The minimum size conductor to be used for instrument analog signal circuits and other low voltage discrete direct current circuits shall be No. 16 AWG. These conductors shall be installed as twisted shielded pairs (TSPs) and/or twisted shielded triads (TSTs) as required for the specific installation and application. A TSP shall contain two No. 16 stranded copper conductors with PVC insulation and a bare copper drain wire twisted together within a conducting shield and a flame-retardant jacket. A TST shall be similar in arrangement except that it shall contain three No. 16 insulated stranded conductors. Cables with 600 V insulation shall be used wherever they are installed in equipment containing circuits that operate at or above 120 V to ground.

As a general rule, no conductor, regardless of voltage, shall be spliced, but there are certain situations where splices and terminations may be required. Low-voltage power conductors in lighting and receptacle circuits may be spliced using UL-listed, insulated, twist-on spring connectors (wirenuts). Splices in conductors to process equipment, control elements, and instruments shall be made with approved compression-type connectors. Final terminations at motors and similar equipment, where removal of the equipment for maintenance can be expected, shall be made with approved bolted connections. Splices are not allowed in control and instrumentation circuit conductors. Where splices are required, they may be made on terminal strips in a junction box (terminal junction box). Control conductors and cables shall be terminated at box, lug-type terminal blocks rated at 600 V.

All conductors shall be identified by a system of unique numbers. The conductor numbers shall be arranged in two parts. The first part shall be a termination identifier consisting of a



series of letters and numbers that uniquely keys the termination to its respective pump station, control enclosure or device, and terminal number. The second part of the conductor number shall be in parentheses and contain the unique termination identifier for the other end of that conductor.

The following is the format to use for single conductor wire tags. Tag information to the left refers to the termination point. Tag information in parenthesis refers to the point of origination.

XXXX XX (XXXX-XXXX-XXXXX / XXXX XX)

Device Terminal Identifier No. (Equipment Tag No.\*/Device Terminal Identifier No.)

\* For wiring within a piece of equipment, control panel, junction box, etc., the Equipment Tag Number is not required, only the Device Identifier and Terminal Number from the point of origination is required.

Example: For a wire connected from terminal block 1 terminal 23 to relay CR1 terminal 9, the correct tag would be TB1-23(CR1-9) at the terminal block and CR1-9(TB1-23) at the relay.

Each conductor shall be identified at each termination point and at all accessible locations, such as handholes, manholes, pullboxes, etc. Conductor and cable tags shall be machine printed and of the heat shrink sleeve type.

## 11.8 Junction Boxes and Enclosures

Junction boxes and pull boxes shall be provided to facilitate the combination of multiple circuits into a single conduit and the pulling of conductors and cables. Junction boxes shall be sized as required by the NEC to accommodate the conductors and cables being installed and conduits connected to them. They shall be constructed of a material suitable for the environment where they will be located. Small boxes shall be cast metal with suitable accessories for wet locations. Larger boxes located outside or in wet areas, shall be Type 316 stainless steel (316 SST) NEMA 4X rated. Boxes located in air conditioned areas shall have a NEMA 1 or 12 rating.

The term terminal junction box (TJB) shall be a term applied to junction boxes that contain terminal strips for the termination of control conductors, small power conductors, or instrumentation cables. They shall be constructed using a junction or pullbox that is suitable for the area where it is to be installed and contain terminal strips that are suitable for the conductors to be terminated. For C-P standard pump stations, a TJB detail is included in the standard drawings. For Program pump stations, a TJB detail is included in Attachment C.

## 11.9 Lighting

Site lighting shall be provided as directed by the DPW personnel for each specific site. Additional task lighting with a manual switch may need to be provided by maintenance personnel for some night repair activities. In addition, where switchgear enclosures are greater than 18 cubic feet, a switch controlled internal fluorescent light shall be provided.



## 11.10 Grounding

Electrical circuits, equipment, and equipment enclosures shall be bonded and grounded as required by Article 250 of the NEC. References to be used in designing grounding systems shall include the following:

- NFPA 70–The National Electrical Code
- IEEE Standard 142–IEEE Recommended Practices for Grounding of Industrial and Commercial Power Systems

A grounding electrode system shall be provided for all pump station site wiring systems as required by the NEC. The grounding electrode system shall be used for neutral grounding of the low-voltage power supply and the equipment ground conductors. Each power supply system shall be connected to a grounding electrode system meeting all requirements of NEC Article 250. Each item within the electrical system shall be bonded together by a bonding conductor sized in accordance with the requirements of the NEC. Grounding electrodes shall be 5/8-inch by 10-foot (minimum) copper-plated steel rod (copperweld or equal).

## 11.11 Transient Voltage Surge Suppression

Transient voltage surge suppressors (TVSS) shall be specified for the electrical distribution system including the main service, distribution, motor control equipment, and branch circuit panelboards per the recommendations of IEEE C62.41.1, C62.41.2, and C62.45 and compliant with UL 1449. The TVSS shall be designed for critical loads at service equipment (IEEE C62.41, Category C3/B3) or distribution panelboard (IEEE C62.41, Category C2/B3) locations. The TVSS equipment will limit the maximum clamp voltage line-to-line or phase-to-neutral per UL 1449 at 400 V for 208Y/120 3-phase and 120 V single-phase, and 800 V for 480Y/277 and 240 V 3-phase systems.

## 11.12 Standby Power Generator System

### 11.12.1 Generator Design

The pump station design shall include a standby power generator. The generator package will be purchased by the C-P, and provided to the pump station project as Owner-furnished Equipment. The Engineer shall include the Owner Furnished Products specification included in Attachment E with the specific generator product submittal included as a supplement to the Owner Furnished Products specification. The generator submittal will be provided by the Project Manager. The pump station construction contractor will install the generator and interconnecting conduit and conductors. The generator supplier will receive and store the equipment at a site in East Baton Rouge Parish, and make it available for pick up by the pump station construction contractor. The generator supplier will provide start up services as part of the generator supply contract.

Generator packages shall consist of a skid-mounted, diesel-engine-driven generator set with an integral double-wall sub-base fuel tank. The design generator size is listed in the Project Definition document. This size shall be verified during the design process by filling out the Electrical Load Estimate Sheet, included in Attachment F.



The generator package will include a sound/ weather enclosure, a silencer for the engine, control panel, and a steel skid. A battery charger will be mounted on the skid and the engine will have a jacket water heater.

For C-P standard pump stations, an ATS will be included in the control panel in accordance with the C-P Standard Details. For automatic transfer control or ATS requirements for Program pump stations, see the example drawings referenced in Section 11.4 Power Distribution and Motor Control Requirements.

The generator shall be mounted outdoors on a concrete pad. If the generator is not located within a fenced pump station site, the generator shall be fenced by itself, with a minimum of 3-foot clearance between the generator and the fence and a gate of sufficient width to allow the entire generator package to be removed.

The Engineer's responsibilities in regard to the generator include:

- Locate the generator(s) on the pump station site.
- If multiple generators are to be used for one pump station, include the Automatic Transfer Control System specification provided in Attachment G. This specification shall be modified by the Engineer as necessary for the specific pump station.
- Provide distribution panel breakers, circuits, and raceways to the generator for the battery charger (115 V single-phase), the jacket water heater (115/230 V single-phase depending on generator size) and a duplex ground fault circuit interrupter (GFCI) receptacle inside the generator enclosure. For generators 750 kW and larger, with walk-in style weather and sound enclosures, provide a circuit to the distribution panel mounted in the enclosure.
- Provide access platforms with stairway around the generator if the generator control panel is more than 6 feet abovegrade or the access door is more than 4 feet abovegrade.
- Provide electrical load data to the PM to allow them to verify the generator sizing. Data shall include number of duty pumps, pump motor horsepower, motor voltage and phase, motor starting arrangement (across-the-line, soft start, variable frequency drive, etc.), and number and size of auxiliary loads such as lights, exhaust fans, heaters, sump pumps, odor scrubbing equipment, etc. The Electrical Load Estimate Sheet to be filled out by the Engineer is included in Attachment F. The Microsoft Excel version of the estimate sheet may be obtained from the PM.
- Provide jacket heater 120 V receptacle (for 250 kW and smaller generators) and convenience receptacle. For larger generators, the size of the jacket water heater will be provided with the generator size.
- Provide sealed engineering drawings of the generator installation for submission to the Louisiana State Fire Marshal for the generator-mounted fuel tank permit.

The PM will supply the designer with the following information:

- Preliminary and final generator size and manufacturer's data for the proposed equipment.



- Verified generator size and manufacturer's data for the proposed equipment after the designer provides electrical load data.
- Location where the generator will be available for pick up by the installing contractor. This location is included in Attachment E.

Additional power distribution design requirements are specified in 11.4 Power Distribution and Motor Control Requirements.

## 11.12.2 Generator Permits Description

### SPCC/SPC Compliance

Both Louisiana Department of Environmental Quality (LDEQ) and EPA have regulations that require facilities with an onsite aggregate oil storage capacity greater than 1,320 gallons to develop a spill prevention control and countermeasure plan (SPCC Plan). While the EPA requirement includes oils, LDEQ includes all substances listed in the LDEQ Notification Regulations in LAC 33:I.3931, and for pump stations collocated with other DPW facilities, the SPCC Plan will need to include any substances on that list. For facilities with less than 10,000 gallons of total storage and no single tank with a capacity greater than 5,000 gallons, a Tier I SPCC Plan can be developed using the Tier I SPCC Plan template found at the EPA website (<http://www.epa.gov/ceppo/web/content/spcc/tier1temp.htm>). For facilities with greater than 10,000 gallons of total storage or a single tank with a capacity greater than 5,000, see the brochure, *A Facility Owner/Operator's Guide to Oil Pollution Prevention - Updated (PDF)*, for a list of required SPCC Plan elements. This brochure can be found at the EPA website (<http://www.epa.gov/ceppo/web/content/spcc/index.htm>).

### Fire Marshal Requirements

The generator packages consist of skid-mounted, diesel-engine-driven generator sets with an integral double-wall sub-base fuel tank. The Louisiana Office of State Fire Marshal Code Enforcement and Building Safety requires that any facility that contains a storage tank undergo a review and approval process. The review requires the submittal of the following:

- The exact location of the pump station including any structures within 20 to 50 feet of the generators. The location must comply with NFPA 30 Storage of Liquids in Tanks - Aboveground Storage Tanks, Table 22.4.11 (b).
- The make, model, and dimensions of the generator/fuel tank.
- The make, model, and dimensions of the fuel tank and verification of whether or not it will have a fire rating.
- Professional Engineer stamped construction plans.
- A Louisiana State Fire Marshal's Office Plan Review Application shall be completed.
- A Louisiana State Fire Marshal's Office Storage Tank System Review Checklist shall be completed.
- An evaluation fee of \$75, to be paid by DPW.

Once this information has been provided to the Fire Marshal's Office, it will go under review (approximately 5 to 10 days). After the pump station has been inspected, an official



letter from the Louisiana State Fire Marshal's Office will be issued stating that it has been reviewed and approved.

### 11.12.3 PDP Pump Station Design Firm Responsibilities

The PDP pump station design firm responsibilities follow:

- For pump stations with a single generator that has a usable fuel tank value greater than 1320 gallons (typically 600 kW or greater), submit a contour map of the pump station location and site layout of the pump station to the Project Manager for approval.
- For generators where the sum of the useable fuel tank volume exceeds 10,000 gallons, submit a complete facility SPCC Plan to the Project Manager for approval ([http://www.epa.gov/oem/docs/oil/spcc/tier1template\\_edit.doc](http://www.epa.gov/oem/docs/oil/spcc/tier1template_edit.doc)).
- Submit to the PM a complete Review Packet for Louisiana State Fire Marshal approval. Packet to include:
  - Exact location of the pump station including any structures within 20 to 50 feet of the generators. Location must comply with NFPA 30 Storage of Liquids in Tanks – Aboveground Storage Tanks, Table 22.4.11(b)
  - The make, model, and dimensions of the generator/fuel tank
  - The make, model, and dimensions of the fuel tank, and verification of whether or not it will have a fire rating
  - Plan Review Application
  - Storage Tank System Review Checklist
  - Professional Engineer stamped drawings of the construction plans

### 11.12.4 Program Manager Responsibilities to Designers

The PM's responsibilities to designers follow:

- Review SPCC plans for completeness ( to ensure that all sections have been addressed)
- Review State Fire Marshal submitted packages for completeness
- Forward State Fire Marshal package to Generator Coordinator. Generator coordinator will deliver package to DPW to attach payment and submit

# 12. Instrumentation and Control Requirements

---

## 12.1 Applicable Codes and Standards

All applicable codes are discussed within this Section.

The *Equipment and Instrument Tagging Requirements* shall be followed to develop tag numbering.

## 12.2 Specific Control Panel and PLC System Design Requirements

### 12.2.1 C-P Standard Pump Stations (Type I and II)

C-P Standard Pump Stations, Type I and II, are specified under C-P Master Specification, Section 805, Submersible Wastewater Pump Station. Obtain the specification from the Program web site, <http://www.brprojects.com/SSOProgram/DesignMasterSpecs.aspx?grpID=cc> and follow all requirements included.

For Type I pump stations, the controls, PLC system, and pump motor starters will be integrated in a single control panel enclosure. Design and wiring requirements are shown on the C-P Standard Drawings #805-02 through 805-04 and 805-10 through 805-11. Obtain these plans and follow all requirements. See Electrical section paragraph 11.4.1, C-P Standard Pump Stations for additional details.

For Type II pump stations, the controls, PLC system, and VFDs will be included in an electrical building. The C-P standard drawings for a Type II pump station include the following drawings for control panels, PLC hardware, and wiring details:

Drawing No.	Title
805-12	Control Panel (Type II)
805-13	Power Distribution and Pump Control Diagram (Type II) – 2 Sheets
805-15	PLC Slot 1 Detail (Type II)
805-16	PLC Slot 2 Detail (Type II)
805-17	PLC Slot 3 Detail (Type II)

### 12.2.2 Program Pump Stations

The electrical power distribution system for Program pump stations will require a separate MCC or a switchboard with free standing VFDs, as shown on electrical design example drawings E-1 (Type IIIA Pump Station), E-2 (Type IIIB pump station), E-3, and E-3A (typical VFD Control Diagrams) in Attachment C. A separate free standing control panel is required at each pump station to house a PLC-based control system with associated control devices.



Another separate panel is needed to house the bubbler level control system. For pump stations with two or more wet wells, provide one bubbler control panel with a separate bubbler tube for each wet well. Locate bubbler panels in the electrical room. The bubbler tubes shall be provided with a three-way valve that will allow selection of the basin in which the level is measured for a given wet well.

Attachment D includes the following example drawings for control panels, PLC hardware, and wiring details to be followed for Type IIIA and IIIB pump stations:

<b>Example Drawing No.</b>	<b>Title</b>
I-1	Typical Control Panel Details
I-2	Control Panel Wiring
I-3	Bubbler Panel and Level Controls (2 sheets)
I-4	PLC I/O Wiring Diagram, Sheet 1
I-4A	Utility/Generator Source Transfer Scheme – Two Generators
I-5	PLC I/O Wiring Diagram, Sheet 2
I-6	PLC I/O Wiring Diagram, Sheet 3
I-7	Example Data Exchange Table for SCADA

The Engineer is responsible for developing detailed design drawings and specifications based on requirements shown on the example drawings included in Attachment D. The Engineer is responsible for customizing the instrumentation drawings to suit each specific application including Piping and Instrumentation Drawings (P&ID) drawings and equipment/instrument tag numbering. The Engineer may obtain the example drawings in AutoCAD from the PM upon request.

### 12.2.3 PLC and Related Hardware

PLC hardware shall meet the Input/Output and communication requirements shown on the drawings for each type of pump station. All PLCs shall include a built-in Ethernet port or card for Ethernet communication. Where shown on the drawings, provide an operator interface for local monitoring/SCADA functions. The operator interface shall be equipped with an Ethernet communication port. Provide Ethernet switch as shown. Typical acceptable manufacturers are listed below:

- a. PLCs):
  - TESCO L2000 PLC+ with Ethernet port
  - Rockwell Automation, Micro Logix series with Ethernet/IP
- b. Operator Interface:
  - TESCO L2000 full size operator interface
  - Rockwell Automation Panel View Plus 700
- c. Ethernet Switch: CISCO





## 12.3 Piping and Instrumentation Drawings

Engineer shall develop detailed P&IDs showing all field instruments, valves, and signal interfaces to control panels, PLCs, motor starters, and VFDs. All equipment, instruments, and valves shown on the P&IDs shall be assigned unique tag numbers in accordance with the Program *Equipment and Instrument Tagging Requirements*. Specific field instrumentation requirements are listed below:

- All pump station discharge forcemains shall be equipped with magnetic flow meters with flow rate and totalized flow indicators. Flow meters shall be located either on an abovegrade slab or in an accessible vault and shall have sufficient upstream and downstream straight pipe diameters in accordance with manufacturer requirements. The flow meter vault shall contain a lockable access hatch. The flow meter control panel shall be located abovegrade, adjacent to the vault/meter, or in an electrical building.
- A local analog pressure gauge with annular diaphragm seal and discharge pressure switch shall be located just upstream of each check valve on each pump discharge. The pump controls shall monitor the pump discharge pressure switch when the pump is called to operate. If the discharge pressure is detected to be greater than a given setpoint for a preset time delay, the logic will consider that the pump is operating under adverse conditions and the logic will shut down and alarm the pump. The pump station discharge header shall include a local analog pressure gauge and analog pressure transmitter with annular diaphragm seal. Pressure gauge, pressure switches, and discharge pressure transmitter shall follow the C-P standard drawings and specifications, even for Program pump stations.
- A position switch shall be provided on each pump check valve to indicate when the valve is in the open position. The pump controls shall monitor the check valve position switch when the pump is called to operate. If the check valve is not detected to be open after a preset time delay, the logic will consider that there is no pump flow and the logic will shut down and alarm the pump. Refer to Drawing E-3 in Attachment C for specific relay logic used in the example.
- Provide bubbler type level measurement system for wet wells as shown on example Drawing I-3, sheet nos. 1 and 2, included in Attachment D.
- Provide combustible gas analyzers and associated alarm systems as shown on example Drawing I-3, sheet nos. 1 and 2, Attachment D.

## 12.4 Specifications

The Engineer shall prepare a set of Specifications to accompany the set of Drawings. Specifications shall include:

- Component Specifications for all field and panel mounted instrumentation equipment. Include PLC hardware specifications.
- Instrument lists including ranges, set points, scales, and options of instruments as appropriate for the application.



- PLC Input/Output Lists.
- Loop Specifications describing functional requirements.
- Application programming, testing, and start-up requirements. Include provision for future SCADA interface including testing requirements for SCADA data exchange. Refer to Drawing I-7 of Attachment D for an example of the format in which the data exchange shall be provided from the contractor.

## 12.5 Functional Requirements for Pump Station Control System/Sequencing

The pump station control strategy and sequencing for the pump station shall be programmed in the PLC housed in the pump station control panel. This paragraph provides general requirements for pump control and sequencing logic for a typical pump station with four pumps (specifically three duty and one standby pump). The Engineer shall use these guidelines to develop detailed and customized control and sequencing specifications for four, six, and eight pump applications.

### 12.5.1 Pump Control/Sequencing for Rising Levels

1. As the wet well level starts rising, start the LEAD pump at an adjustable preset level "L1," at 50 percent speed (adjustable to higher percent speed). The speed of the LEAD pump is modulated proportional to the level. Should the level start dropping and the pump speed is at 50 percent for a pre-set time or the level is at ALL PUMPS OFF level, stop the single running pump.
2. As the level keeps rising, the LEAD pump speed should increase linearly, proportional to level. When the speed of the LEAD pump reaches 95 percent and/or the level rises to an adjustable pre-set level "L2," start the first lag pump (LAG-1) at 50 percent speed (adjustable to higher percent speed). The speed of the LEAD pump is modulated down and the LAG-1 pump speed is modulated up until both pumps modulate at a common speed, proportional to the wet well level.
3. As the wet well level keeps rising to an adjustable pre-set level "L3" and the pair of pumps (Lead and LAG-1) are operating at 95 percent speed for an adjustable pre-set time, START the LAG-2 pump at 50 percent speed (adjustable to higher percent speed). Modulate the speed of the pair of pumps (LEAD, LAG-1) down and the LAG-2 pump speed up until all three pumps modulate at a common speed proportional to wet well level.
4. As the wet well level keeps rising, the common speed of all three pumps linearly increases proportional to the level. If all three pumps are at 100 percent speed and the level keeps rising to a HIGH-HIGH level set point, generate an alarm. The control logic shall prevent starting the standby pump when all duty pumps are already running.
5. Initial pre-set level differences shall be 1.5 feet.



### 12.5.2 Pump Control/Sequencing for Falling Levels

1. As levels start falling the common speed of the three pumps will be reduced linearly proportional to level, until such time that the speed is at 50 percent (adjustable to higher percent speed) for a pre-set time, and an adjustable pre-set level  $L3'$  between  $L3$  and  $L2$  is reached ( $L3 > L3' > L2$ ), then stop the LAG-2 pump, and modulate the pair of LEAD and LAG-1 pumps at a common speed proportional to the level.
2. As the level keeps falling, such that the common speed of LEAD and LAG-1 pump drops to 50 percent (adjustable) and an adjustable pre-set level of  $L2'$  between  $L2$  and  $L1$  is reached ( $L2 > L2' > L1$ ), then stop the LAG-1 pump, and modulate the single LEAD pump speed proportional to the level.
3. When LEAD falls to ALL PUMPS OFF level ( $L1$ ) and the LEAD pump speed is at 50 percent (adjustable to a higher percent speed) for an adjustable time stop the LEAD pump. Indicate low level status on the panel.
4. If the level falls to a LOW-LOW level set point, generate an alarm and stop all pumps. The pumps shall restart automatically as the level rises, in accordance with Section 12.5.1.

### 12.5.3 Emergency Pump Call Procedure

In the event that the PLC fails, the pressure switches on the bubbler tube, hard-wired to the VFDs, shall be utilized to control the pump station based on level. If the station reaches the HIGH-HIGH level, the LEAD pump will come on at a preset speed on the VFD (typically initially set at 100 percent). The remaining number of duty pumps shall be started sequentially after a pre-set time delay until all available duty pumps are running at a preset speed or the LOW-LOW level pressure switch shuts all the pumps off. The Consultant is responsible for development of customized control logic for each specific pump station. Refer to Drawing I-3, Sheets 1 of 2 and 2 of 2 for example of typical bubbler system and associated level controls.

### 12.5.4 Pump Alternation

Control logic shall include pump alternation scheme to equalize run times on LEAD and LAG pumps.

### 12.5.5 Hardwired Interlock to Prevent Starting of Standby Pump When All Duty Pumps are Running

Hardwired relay based interlock shall be provided for each of the pumps, to be wired into the drive control circuit to prevent starting of the next pump when all duty pumps are already running. In this specific example, when a pump is "called" to run, and all other duty pumps are running, the logic shall generate an interlock to be hardwired into the VFD control circuit of the pump called to run, to prevent drive operation either in manual or automatic mode. This pump can be started if one of the duty pumps stops due to failure or other reason. The pump fail condition should be alarmed. In the case of duplex pump stations with pumps under 30 hp, the hardwired interlock is not necessary, since the electrical system, including the generator, is sized to run both pumps if needed.



### 12.5.6 Pump Failed to Start and Out of Service Logic

If a RUN command is issued to a pump VFD and an ON status is not received within an adjustable time delay, generate a “pump failed to start” alarm and issue a “pump call” to the next pump.

If a pump VFD “Hand-off-Remote” switch is in the OFF position, that pump is considered “Out of Service,” by-pass this pump from sequencing logic until such time that the VFD switch is turned to REMOTE position. To be part of pump sequence logic, the VFD switch must be REMOTE position.

## 12.6 Interface to Collection System SCADA System

DPW intends to implement a SCADA system for monitoring the collection system pump stations at a central location. The collection system SCADA will be a separate project; however, the Engineer shall make provision for adding a cellular radio modem and connection for an antenna in each control panel (at least a 12 inch x 12 inch space in the control panel). The requirements are shown on the C-P standard drawings and on drawings part of Attachment D. On a case-by-case basis the antenna may have to be installed at a convenient location away from the panel. The PLC shall have a provision for an Ethernet data link to the radio modem as shown. All data related to pump stations (e.g., alarms, wet well levels, pump station discharge flow, equipment failure, and intrusion alarms) will be transmitted to the central location via cellular radio link.

Specifications shall include specific application programming requirements for data exchange between each pump station PLC and future SCADA servers via Ethernet. The PLC application program shall include addresses of locations where READ and WRITE bits and words are located within the PLC for use in future SCADA data exchange. Provide documentation and testing of this data exchange “look-up” table as part of the contractor scope of work.

# 13. Pump Station Commissioning and Startup

---

Pump station commissioning and startup is a vital step to confirm the correct operation of the pumps. The Engineer shall include the Pump Station Commissioning specification and checklist, provided in Attachment H, for all Program pump stations. The specification and checklist need to be modified by the Engineer to reflect their particular project. This specification and checklist also needs to be coordinated with the other construction specifications which may also include testing and startup requirements.

The Engineer shall provide direction and design features which allow the pump station to be commissioned. Consideration shall be given during the design as to whether the pump station will be tested with clean water in a recirculation mode or by pumping clean water or sewage through the discharge piping. If flow is to be recirculated, branch connections shall be provided to allow for the installation of temporary recirculation piping, or other means of providing for recirculated flow. While it is the contractor's responsibility to come up with the detailed commissioning and start up plan, it is the Engineer's responsibility to include design features which will allow the commissioning to occur without modifications to the pump station that may lead to a claim by the contractor.



# 14. Pump Station Design Checklists

---

Pump Station Design Checklists are included in Attachment I. The checklists shall be completed by the Engineer and submitted as part of the applicable design submittal.

The checklists are intended to serve as a tool for all Engineers involved in wastewater pump station design projects. They provide an outline of the design process and alert the user to issues sometimes overlooked in the process. The checklists are not intended as detailed design tools, or as a source of fundamental design principles and formula.

The checklists are designed to correspond to the design phases defined in the *Standard Scope of Engineering Services*, which is included in the *Program Requirements for Engineers*.

## 14.1 Preliminary Design (30%)

This checklist is intended to guide the project from first client contact through the development of a 30% design submittal. The list identifies the environmental, regulatory, and legal issues that shall be addressed early in a pump station project. It establishes the data collection efforts needed for subsequent design work.

## 14.2 60% Engineering Design

The second checklist takes the project from preliminary design through 60% design, including specifications. There are detailed checklists for the pump station design, the specifications, and a general Quality Assurance (QA) checklist for the drawings.

## 14.3 Final Design and Contract Documents (90% and 100% Design)

The final checklist takes the project from 60% design to the production of contract documents, including specifications. Only Project Manager and C-P comments are to be incorporated after the 90% submittal. There are detailed checklists for the pump station design, the specifications, and a general QA checklist for the drawings.

The Engineer shall direct any questions regarding the use or applicability of the checklists to the Project Manager.





Attachment A  
Pump Station Hydraulic System Curve(s) Assumptions

ATTACHMENT A

# Pump Station Hydraulic System Curve(s) Assumptions

---

(to be provided by the Program Manager for each pump station as part of the Project Definition Document, unless force main is included in the project)

1. High Wet Well Level Elevation \_\_\_\_\_
2. Low Wet Well Level Elevation \_\_\_\_\_
3. Force Main Discharge High Hydraulic Grade Line (HGL) elevation \_\_\_\_\_
4. Force Main Discharge Low HGL Elevation \_\_\_\_\_
5. Pipe Line Material \_\_\_\_\_
6. Pipe Line Inside Diameter(s) (ID) \_\_\_\_\_
7. Pump Design Point Head \_\_\_\_\_ (ft) and Flow (Q) \_\_\_\_\_ (gpm)
  - a. C value \_\_\_\_\_
  - b. Static Head \_\_\_\_\_
    - i. Discharge HGL \_\_\_\_\_
    - ii. Suction HGL \_\_\_\_\_
8. Boundary System Curve - Upper Boundary Assumptions
  - a. C value \_\_\_\_\_
  - b. Static Head \_\_\_\_\_
    - i. Discharge HGL \_\_\_\_\_
    - ii. Suction HGL \_\_\_\_\_
9. Boundary System Curve - Lower Boundary Assumptions
  - a. C value \_\_\_\_\_
  - b. Static Head \_\_\_\_\_
    - i. Discharge HGL \_\_\_\_\_
    - ii. Suction HGL \_\_\_\_\_
10. Assumed number of pumps installed \_\_\_\_\_

**Attachment B**  
**Example Pump Station Drawings**

---

1 2 3 4 5 6

A  
B  
C  
D

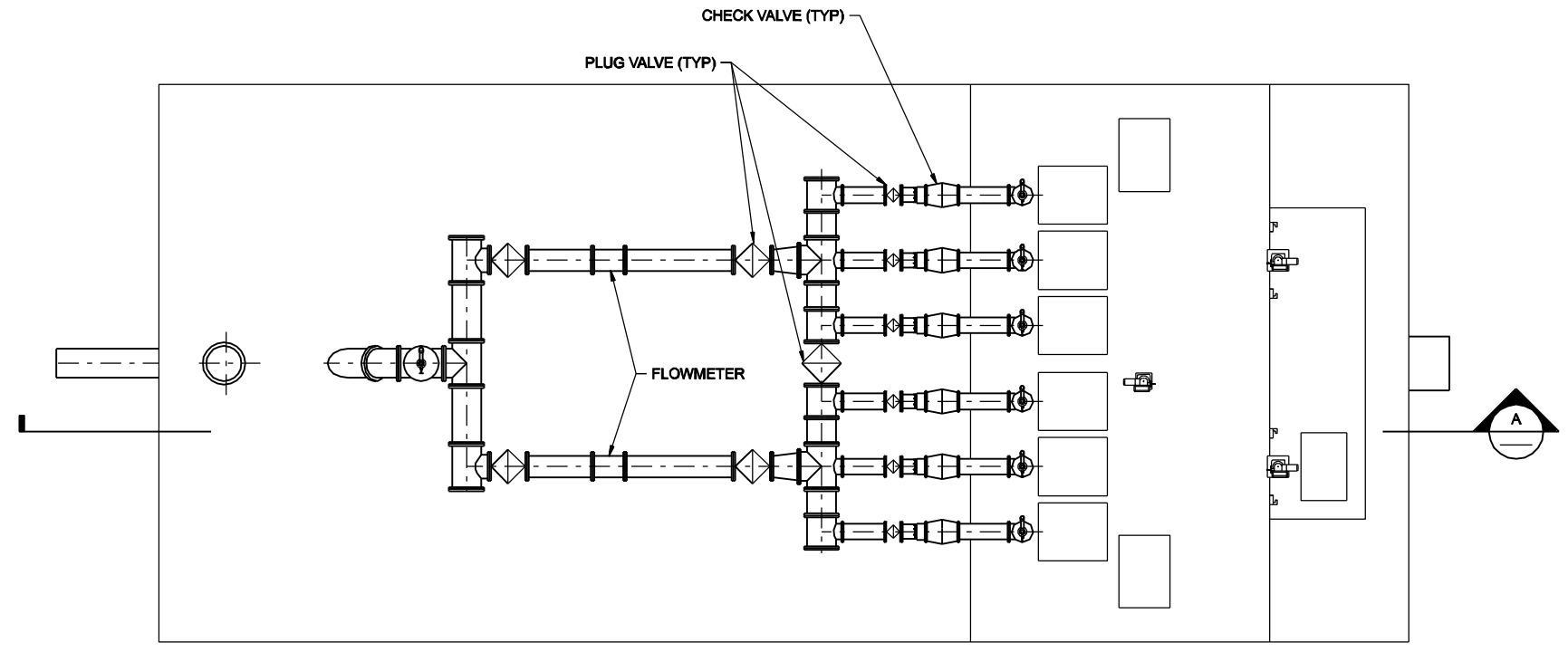

**UPPER PLAN**  
1/8"=1'-0"

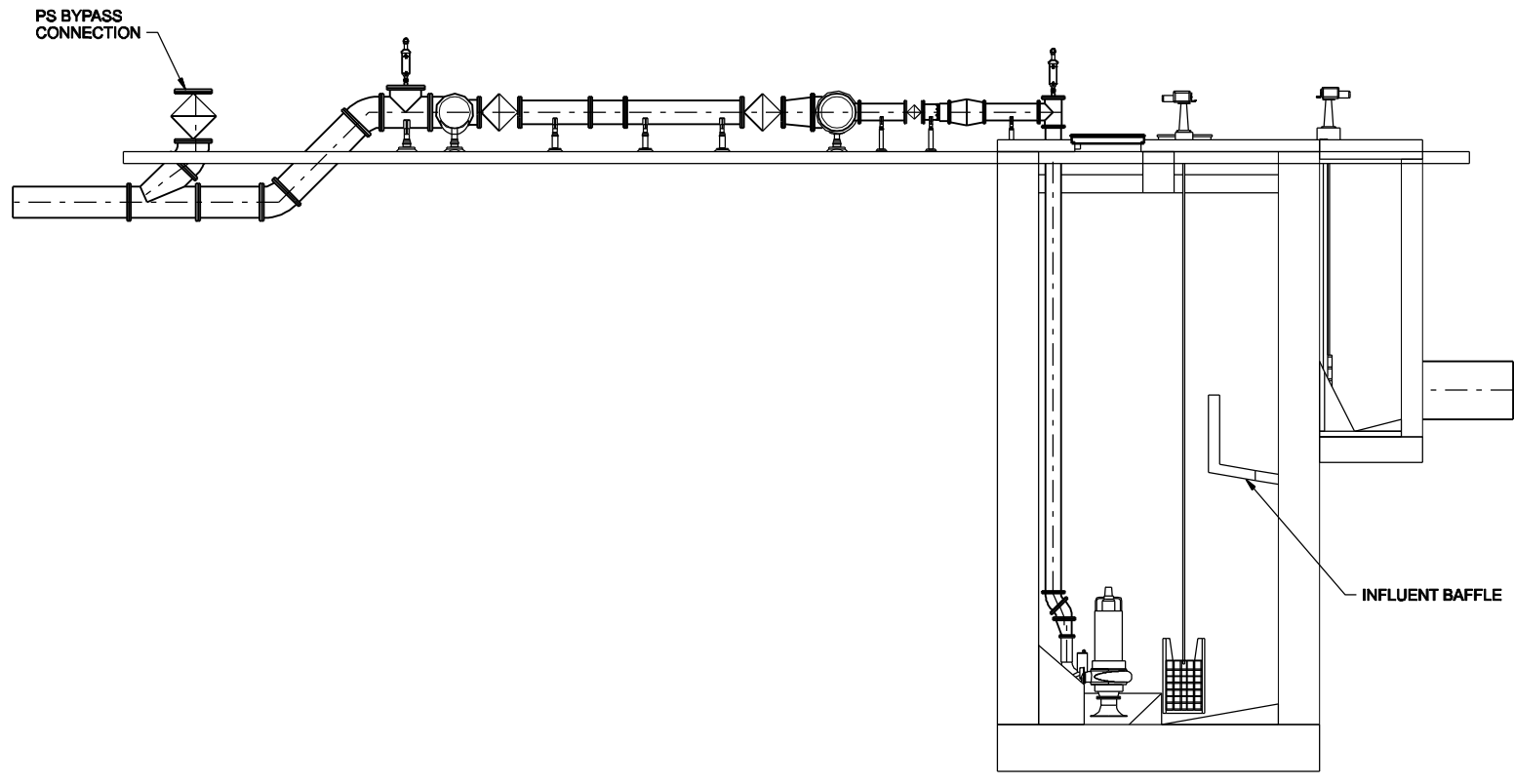

**A SECTION**  
1/8"=1'-0"

**CH2MHILL**

CITY OF BATON ROUGE  
PARISH OF EAST BATON ROUGE  
DEPARTMENT OF PUBLIC WORKS  
BATON ROUGE, LOUISIANA

PROCESS MECHANICAL  
PUMP STATION  
PLAN AND SECTION

VERIFY SCALE	
BAR IS ONE INCH ON ORIGINAL DRAWING.	
DATE	DECEMBER 2008
PROJ	350589
DWG	FIGURE 1
SHEET	

NO.	DATE	DGN	DR	REVISION	CHECKED-BY	APPROVED-BY
				CHK	K. MURRAY	APVD

REUSE OF DOCUMENTS: THIS DOCUMENT AND THE IDEAS AND DESIGNS INCORPORATED HEREIN, AS AN INSTRUMENT OF PROFESSIONAL SERVICE, IS THE PROPERTY OF CH2M HILL AND IS NOT TO BE USED, IN WHOLE OR IN PART, FOR ANY OTHER PROJECT WITHOUT THE WRITTEN AUTHORIZATION OF CH2M HILL. © CH2M HILL 2004. ALL RIGHTS RESERVED.

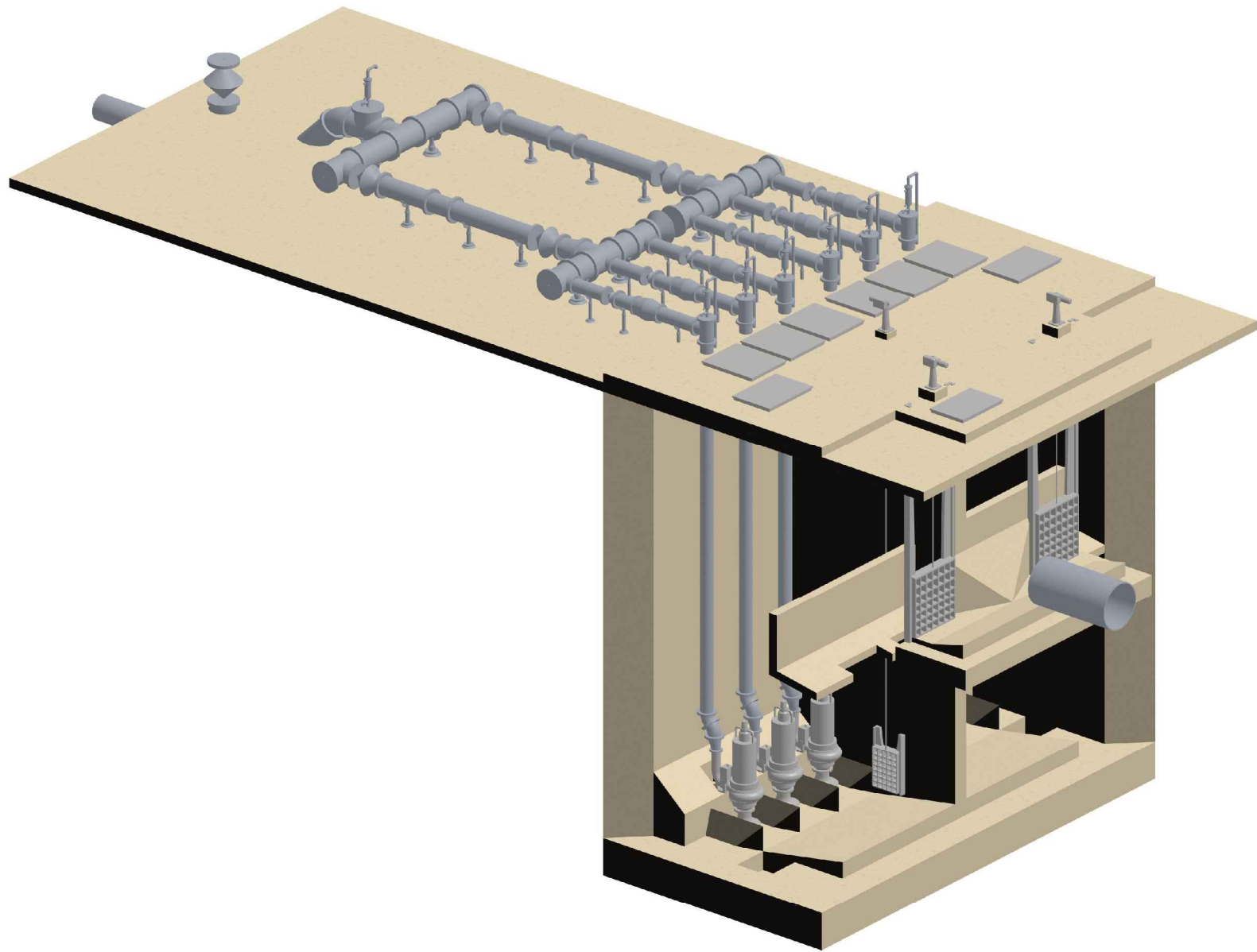

**ILLUSTRATIVE ISOMETRIC**  
NTS

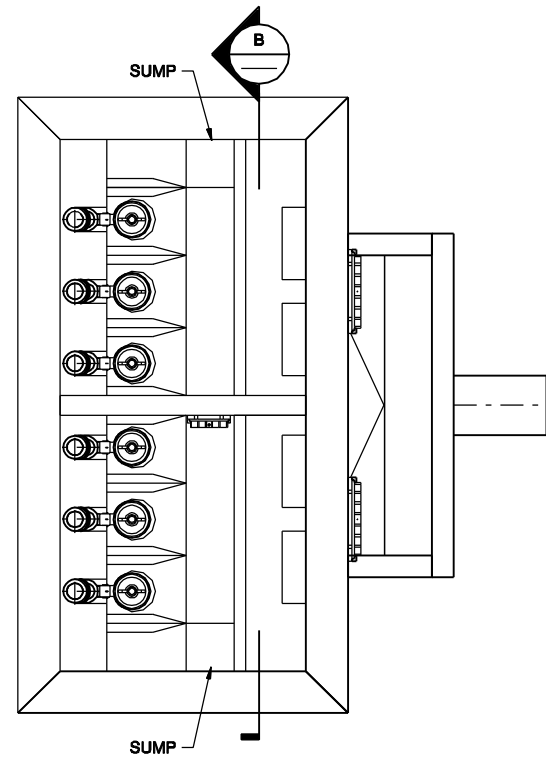

**LOWER PLAN**  
1/8"=1'-0"

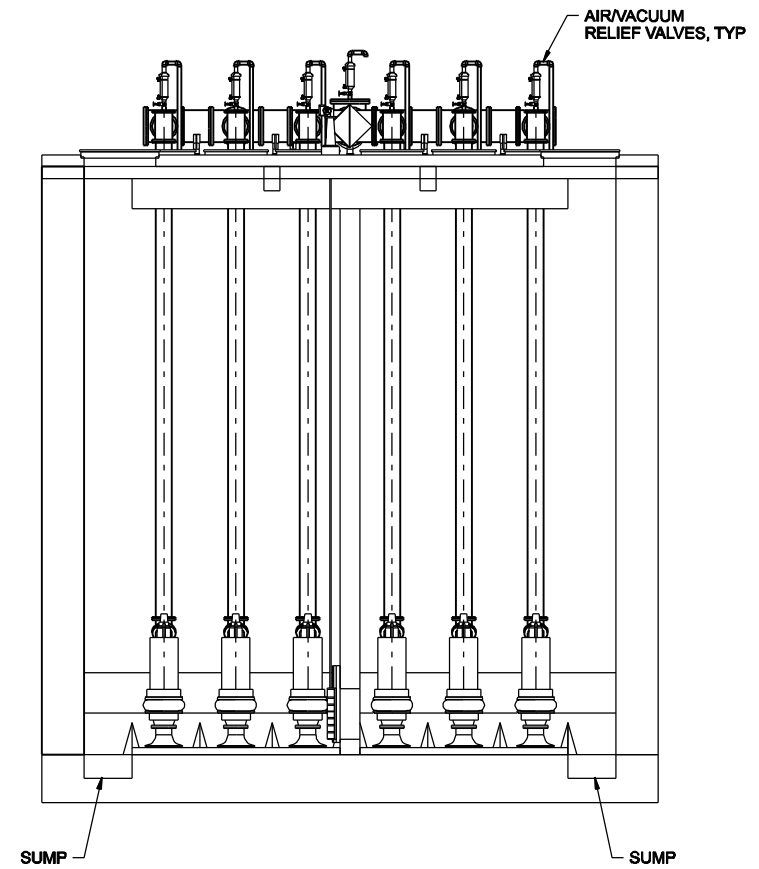

**B SECTION**  
1/8"=1'-0"

**CH2MHILL**

PROCESS MECHANICAL  
PUMP STATION  
LOWER PLAN, SECTION, AND ISOMETRIC

CITY OF BATON ROUGE  
PARISH OF EAST BATON ROUGE  
DEPARTMENT OF PUBLIC WORKS  
BATON ROUGE, LOUISIANA

NO.	DATE	DGN	DR	CHK	APVD	BY	APVD
				J HAWKEY	K MURRAY		
				REVISION	CHECKED-BY	APPROVED-BY	

VERIFY SCALE	
BAR IS ONE INCH ON ORIGINAL DRAWING.	
DATE	AUGUST 2008
PROJ	350589
DWG	FIGURE 2
SHEET	

REUSE OF DOCUMENTS: THIS DOCUMENT AND THE IDEAS AND DESIGNS INCORPORATED HEREIN, AS AN INSTRUMENT OF PROFESSIONAL SERVICE, IS THE PROPERTY OF CH2MHILL AND IS NOT TO BE USED, IN WHOLE OR IN PART, FOR ANY OTHER PROJECT WITHOUT THE WRITTEN AUTHORIZATION OF CH2MHILL. © CH2MHILL 2004. ALL RIGHTS RESERVED.

**Attachment C**  
**Example Electrical Drawings**

---

1 2 3 4 5 6

A  
B  
C  
D

# ATTACHMENT "C"

**CH2MHILL**

EXAMPLE  
PROGRAM PUMP STATIONS (PDP)  
ATTACHMENT "C"

CITY OF BATON ROUGE  
PARISH OF EAST BATON ROUGE  
DEPARTMENT OF PUBLIC WORKS  
BATON ROUGE, LOUISIANA

DGN	NO.	DATE
	1	09/2010

DR	CHK	APVD
J O'CONNOR	J EFAW	J BALDWIN

PK	BY
	APVD

VERIFY SCALE	
BAR IS ONE INCH ON ORIGINAL DRAWING.	
DATE	MAY 2012
PROJ	350589
DWG	E-0
SHEET	

REUSE OF DOCUMENTS: THIS DOCUMENT AND THE IDEAS AND DESIGNS INCORPORATED HEREIN AS AN INSTRUMENT OF PROFESSIONAL SERVICE IS THE PROPERTY OF CH2M HILL AND IS NOT TO BE USED, IN WHOLE OR IN PART, FOR ANY OTHER PROJECT WITHOUT THE WRITTEN AUTHORIZATION OF CH2M HILL. © CH2M HILL 2004. ALL RIGHTS RESERVED.

FOR NOTES AND LEGENDS  
SEE E-1, SHEET 2 OF 2

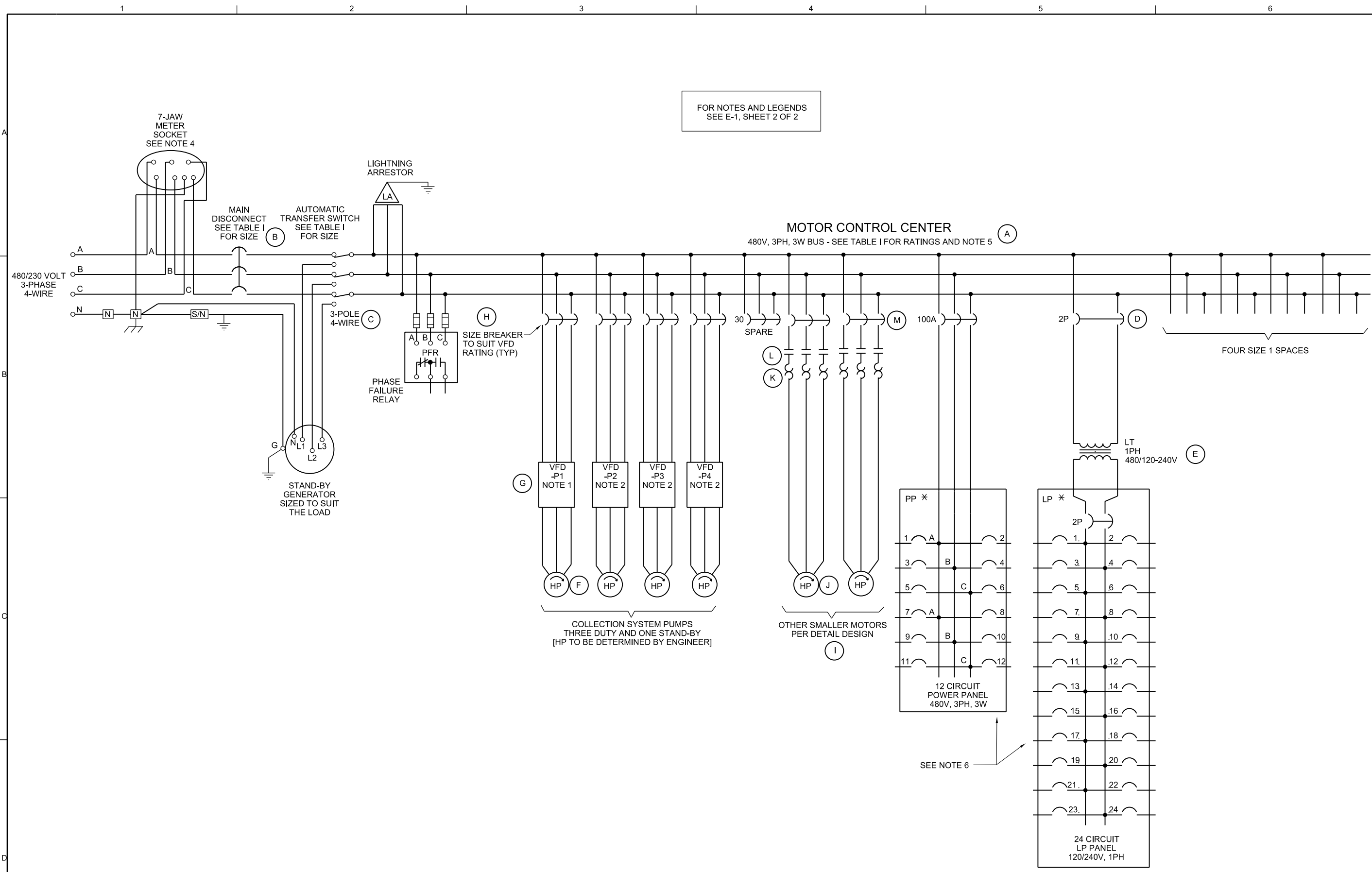

NO.	DATE	DGN	DR	CHK	REVISION	BY	APVD
		J O'CONNOR	J O'CONNOR	J. EFRAW		J. BALDWIN	APVD

CITY OF BATON ROUGE  
PARISH OF EAST BATON ROUGE  
DEPARTMENT OF PUBLIC WORKS  
BATON ROUGE, LOUISIANA

**CH2MHILL**  
TYPE IIIA PUMP STATION  
ELECTRICAL THREE LINE DIAGRAM

VERIFY SCALE	
BAR IS ONE INCH ON ORIGINAL DRAWING.	
DATE	MAY 2012
PROJ	350589
DWG	E-1
SHEET	1 of 2

REUSE OF DOCUMENTS: THIS DOCUMENT, AND THE IDEAS AND DESIGNS INCORPORATED HEREIN, AS AN INSTRUMENT OF PROFESSIONAL SERVICE, IS THE PROPERTY OF CH2M HILL AND IS NOT TO BE USED, IN WHOLE OR IN PART, FOR ANY OTHER PROJECT WITHOUT THE WRITTEN AUTHORIZATION OF CH2M HILL. © CH2M HILL 2004. ALL RIGHTS RESERVED.



TABLE E-1

PUMP STATION NO. _____			
DESIG.	ITEM DESCRIPTION	ITEM VALUE	UNITS
A	UTILITY SHORT CIRCUIT RATING		KAIC
B	UTILITY MAIN DISCONNECT CIRCUIT BREAKER SIZE		AMPS
C	AUTOMATIC TRANSFER SWITCH RATING		AMPS
D	TRANS T1 PRIMARY CIRCUIT BREAKER		AMPS
E	TRANS T1 SIZE		KVA
F	PUMP MOTOR SIZE		HP
G	VFD RATING		KVA
H	PUMP MOTOR BREAKER SIZE		AMPS
I	QUANTITY OF SMALLER MOTORS		EACH
J	SMALLER MOTOR SIZE		HP
K	SMALLER MOTOR STARTER SIZE		NEMA SIZE
L	SMALLER MOTOR VFD SIZE		KVA
M	SMALLER MOTOR BREAKER SIZE		AMPS
N			
O			

NOTES:

- THIS DRAWING PROVIDES GENERAL REQUIREMENTS. THE SPECIFIC SIZE AND QUANTITY OF PUMPS, THE USE OF FIXED SPEED OR VFD AND THE SPECIFIC REQUIREMENTS FOR ANCILLARY AND ELECTRIC BUILDING LOADS ARE PROVIDED IN THE SPECIFIC CONTRACT DOCUMENTS FOR THE INDIVIDUAL PUMP STATIONS. ANY VALUES SHOWN ON SHEET 1 OF 2 ARE FOR EXAMPLE ONLY. THE DESIGN ENGINEER SHALL MAKE APPROPRIATE CHANGES TO THESE DRAWINGS TO MAKE THEM SPECIFIC TO EACH PUMP STATION.
- ALL DRIVES ABOVE 150HP SHALL BE FREE STANDING, 18 PULSE PWM TYPE. DRIVES SHALL MEET IEEE 519-1992 HARMONIC DISTORTION LIMITS AT THE MCC BUS WHEN ALL DUTY PUMPS ARE RUNNING ON UTILITY AND GENERATOR.
- WIRE ATS SIGNALS TO PUMP CONTROL PANEL.
- COORDINATE WITH ELECTRIC UTILITY. PROVIDE CT ENCLOSURE WITH METER SOCKET WHERE REQUIRED.
- VERIFY AVAILABLE SHORT CIRCUIT CURRENT WITH SERVICING ELECTRIC UTILITY.
- PROVIDE PANELS SIZED ACCORDING TO SPECIFIC LOAD REQUIREMENTS OF THE PUMP STATION AND ASSOCIATED GENERATOR. 480 VOLT PANELS MAY BE EXCLUDED AS DICTATED. SEE PANEL SCHEDULES THIS SHEET.
- COORDINATE TRANSFORMER AND BREAKER SIZES BASED ON SPECIFIC LOADS, GENERATOR JACKET WATER HEATER AND AIR CONDITIONER.

LEGEND:

- VFD = VARIABLE FREQUENCY DRIVE
- TVSS = TRANSIENT VOLTAGE SURGE SUPPRESSOR
- PFR = PHASE FAILURE RELAY
- ATS = AUTOMATIC TRANSFER SWITCH
- LT = LIGHTING TRANSFORMER
- LP = LIGHTING PANEL

PANEL SCHEDULES

PANEL: LP					
MAIN RATING _____ AMPS			AIC RATING _____ KAIC		
DESCRIPTION	AMPS / POLES	CIRCUIT NO.	CIRCUIT NO.	AMPS / POLES	DESCRIPTION
PLC & DC POWER SUPPLY	20/1	1	2	20/1	LEVEL CONTROL & CGD
STATION ALARM AND INDICATORS	20/1	3	4	20/1	CONTROL PANEL LIGHTS RECEPT. & HEATERS
AREA LIGHTS	20/1	5	6	20/1	GEN. BATTERY CHARGER
GEN JACKET WATER HEATER (SEE NOTE 7)	XX/2	7	8	20/1	GEN. MAINTENANCE RECEPTACLE
		9	10		
		11	12		
		13	14		
		15	16		
		17	18		
		19	20		
		21	22		
		23	24		

PANEL: LP					
MAIN RATING _____ MLO AMPS			AIC RATING _____ KAIC		
DESCRIPTION	AMPS / POLES	CIRCUIT NO.	CIRCUIT NO.	AMPS / POLES	DESCRIPTION
		1	2		
		3	4		
		5	6		
		7	8		
		9	10		
		11	12		

**CH2MHILL**

CITY OF BATON ROUGE  
PARISH OF EAST BATON ROUGE  
DEPARTMENT OF PUBLIC WORKS  
BATON ROUGE, LOUISIANA

TYPE IIIA PROGRAM PUMP STATIONS  
ELECTRICAL ONE LINE DIAGRAM

VERIFY SCALE

BAR IS ONE INCH ON ORIGINAL DRAWING.

DATE MAY 2012

PROJ 350589

DWG E-1

SHEET 2 of 2

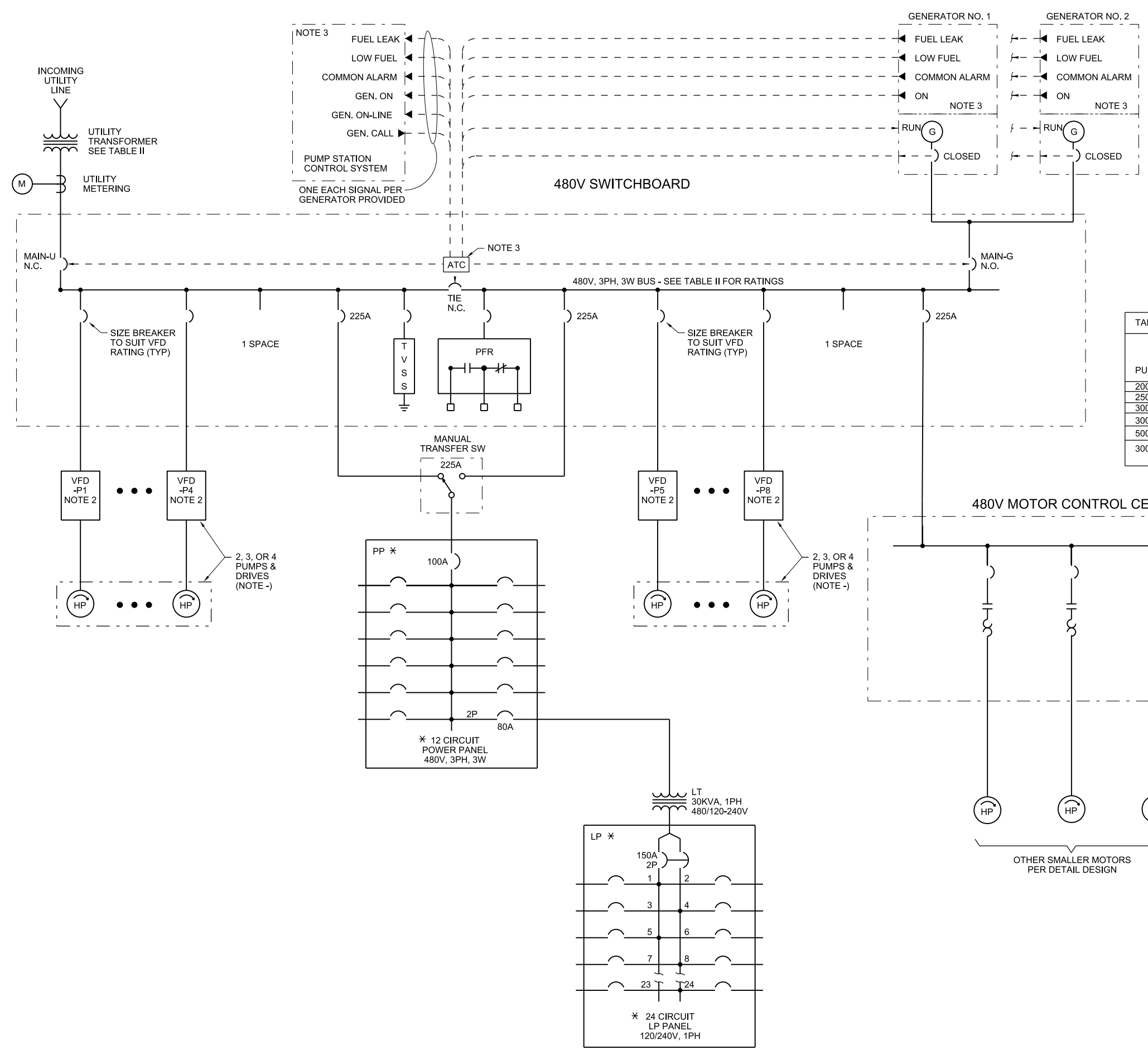

- NOTES:**
- THIS DRAWING PROVIDES GENERAL REQUIREMENTS. THE SPECIFIC SIZE AND QUANTITY OF PUMPS, THE USE OF FIXED SPEED OR VFD AND THE SPECIFIC REQUIREMENTS FOR ANCILLARY AND ELECTRIC BUILDING LOADS ARE PROVIDED IN THE SPECIFIC CONTRACT DOCUMENTS FOR THE INDIVIDUAL PUMP STATIONS. THE DESIGN ENGINEER SHALL MAKE APPROPRIATE CHANGES TO THESE DRAWINGS TO MAKE THEM SPECIFIC TO EACH PUMP STATION.
  - ALL DRIVES ABOVE 150HP SHALL BE FREE STANDING, 18 PULSE PWM TYPE. DRIVES SHALL MEET IEEE 519-1992 HARMONIC DISTORTION LIMITS AT THE MCC BUS WHEN ALL DUTY PUMPS ARE RUNNING ON UTILITY AND GENERATOR.
  - SEE DRAWING I-4A FOR ADDITIONAL INFORMATION AND REQUIREMENTS FOR TWO GENERATOR INTERFACE. STANDBY GENERATORS TO BE DETERMINED DURING DESIGN AND SIZED TO SUIT THE LOAD.
  - COORDINATE WITH ELECTRIC UTILITY.
- \* PROVIDE PANELS SIZED ACCORDING TO SPECIFIC LOAD REQUIREMENTS OF THE PUMP STATION AND ASSOCIATED GENERATOR. 480 VOLT PANELS MAY BE EXCLUDED AS DICTATED.

- LEGEND:**
- VFD = VARIABLE FREQUENCY DRIVE
  - TVSS = TRANSIENT VOLTAGE SURGE SUPPRESSOR
  - PFR = PHASE FAILURE RELAY
  - ATC = AUTOMATIC TRANSFER CONTROLS
  - LT = LIGHTING TRANSFORMER
  - LP = LIGHTING PANEL

**TABLE II : EXAMPLE OF TYPICAL EQUIPMENT RATINGS**

PUMP HP	NO. OF PUMPS		UTILITY TRANSF. KVA	MAIN/TIE BREAKER RATING AMPS	BUS AMPS RATING	BUS AIC KILO-AMPS
	DUTY	STAND-BY				
200	3	1	1000	1500	2000	42 KA
250						
300						
300	5	1	2500	3200	4000	65 KA
500						
300	7	1	2500	3200	4000	65 KA
300						

CH2MHILL

EXAMPLE

CITY OF BATON ROUGE  
PARISH OF EAST BATON ROUGE  
DEPARTMENT OF PUBLIC WORKS  
BATON ROUGE, LOUISIANA

**TYPE III B PROGRAM PUMP STATIONS (PDP)  
ELECTRICAL ONE LINE DIAGRAM  
TYPE II PUMP STATION**

NO. DATE

DR J O'CONNOR

REVISION

CHK J EFRAW

BY APVD J BALDWIN

APVD

VERIFY SCALE

BAR IS ONE INCH ON ORIGINAL DRAWING.

DATE MAY 2012

PROJ 350589

DWG E-2

SHEET

REUSE OF DOCUMENTS: THIS DOCUMENT, AND THE IDEAS AND DESIGNS INCORPORATED HEREIN, IS THE PROPERTY OF CH2MHILL AND IS NOT TO BE USED, IN WHOLE OR IN PART, FOR ANY OTHER PROJECT WITHOUT THE WRITTEN AUTHORIZATION OF CH2MHILL.

© CH2MHILL 2004. ALL RIGHTS RESERVED.

FILENAME: 350589-Baton Rouge\SWWTP\Standards\ dn05e02\_350589.dgn PLOT DATE: 2012/05/31 PLOT TIME: 12:03:48 PM

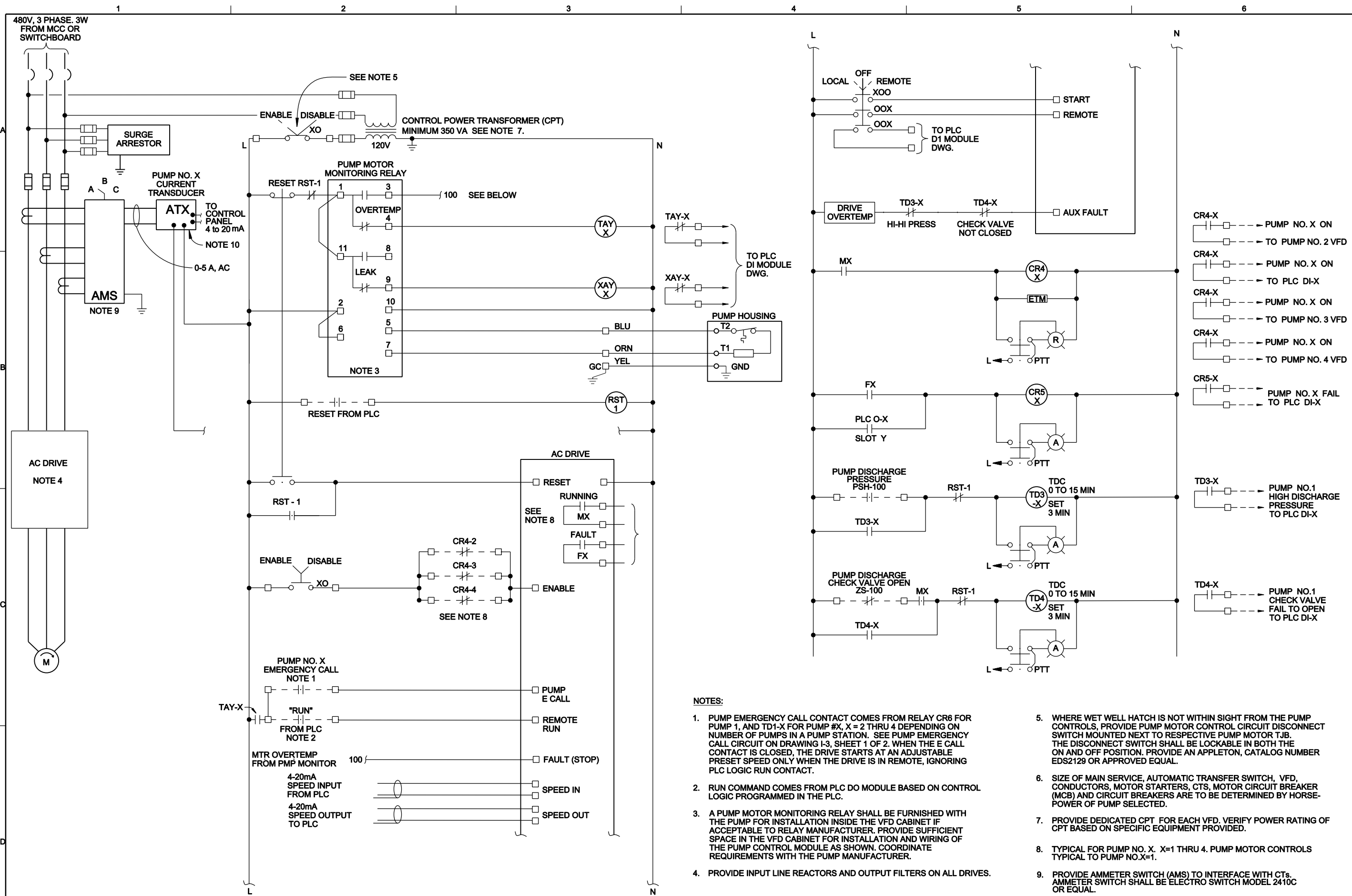

**TYPICAL PUMP VFD CONTROL DIAGRAM LESS THAN 150 HP**

X = 1, 2, 3, 4

**NOTES:**

- PUMP EMERGENCY CALL CONTACT COMES FROM RELAY CR6 FOR PUMP 1, AND TD1-X FOR PUMP #X, X = 2 THRU 4 DEPENDING ON NUMBER OF PUMPS IN A PUMP STATION. SEE PUMP EMERGENCY CALL CIRCUIT ON DRAWING I-3, SHEET 1 OF 2. WHEN THE E CALL CONTACT IS CLOSED, THE DRIVE STARTS AT AN ADJUSTABLE PRESET SPEED ONLY WHEN THE DRIVE IS IN REMOTE, IGNORING PLC LOGIC RUN CONTACT.
- RUN COMMAND COMES FROM PLC DO MODULE BASED ON CONTROL LOGIC PROGRAMMED IN THE PLC.
- A PUMP MOTOR MONITORING RELAY SHALL BE FURNISHED WITH THE PUMP FOR INSTALLATION INSIDE THE VFD CABINET IF ACCEPTABLE TO RELAY MANUFACTURER. PROVIDE SUFFICIENT SPACE IN THE VFD CABINET FOR INSTALLATION AND WIRING OF THE PUMP CONTROL MODULE AS SHOWN. COORDINATE REQUIREMENTS WITH THE PUMP MANUFACTURER.
- PROVIDE INPUT LINE REACTORS AND OUTPUT FILTERS ON ALL DRIVES.
- WHERE WET WELL HATCH IS NOT WITHIN SIGHT FROM THE PUMP CONTROLS, PROVIDE PUMP MOTOR CONTROL DISCONNECT SWITCH MOUNTED NEXT TO RESPECTIVE PUMP MOTOR TJB. THE DISCONNECT SWITCH SHALL BE LOCKABLE IN BOTH THE ON AND OFF POSITION. PROVIDE AN APPLETON, CATALOG NUMBER EDS2129 OR APPROVED EQUAL.
- SIZE OF MAIN SERVICE, AUTOMATIC TRANSFER SWITCH, VFD, CONDUCTORS, MOTOR STARTERS, CTS, MOTOR CIRCUIT BREAKER (MCB) AND CIRCUIT BREAKERS ARE TO BE DETERMINED BY HORSE-POWER OF PUMP SELECTED.
- PROVIDE DEDICATED CPT FOR EACH VFD. VERIFY POWER RATING OF CPT BASED ON SPECIFIC EQUIPMENT PROVIDED.
- TYPICAL FOR PUMP NO. X. X=1 THRU 4. PUMP MOTOR CONTROLS TYPICAL TO PUMP NO.X=1.
- PROVIDE AMMETER SWITCH (AMS) TO INTERFACE WITH CTS. AMMETER SWITCH SHALL BE ELECTRO SWITCH MODEL 2410C OR EQUAL.
- PROVIDE CURRENT TRANSDUCER AS SHOWN; 0-5 A, AC, CT INPUT AND 4-20 MA OUTPUT.

**CH2MHILL**  
 EXAMPLE  
 TYPE IIIA PUMP STATION  
 VFD CONTROL WIRING DIAGRAM

VERIFY SCALE	
BAR IS ONE INCH ON ORIGINAL DRAWING.	
DATE	MAY 2012
PROJ	350589
DWG	E-3
SHEET	

NO.	1	DATE	09/2010
DSGN	J. O'CONNOR	CHK	J. EFRAW
REVISION		APVD	J. BALDWIN
PK		BY	
APVD		BY	
UPDATED DESIGN REQUIREMENTS			

CITY OF BATON ROUGE  
 PARISH OF EAST BATON ROUGE  
 DEPARTMENT OF PUBLIC WORKS  
 BATON ROUGE, LOUISIANA

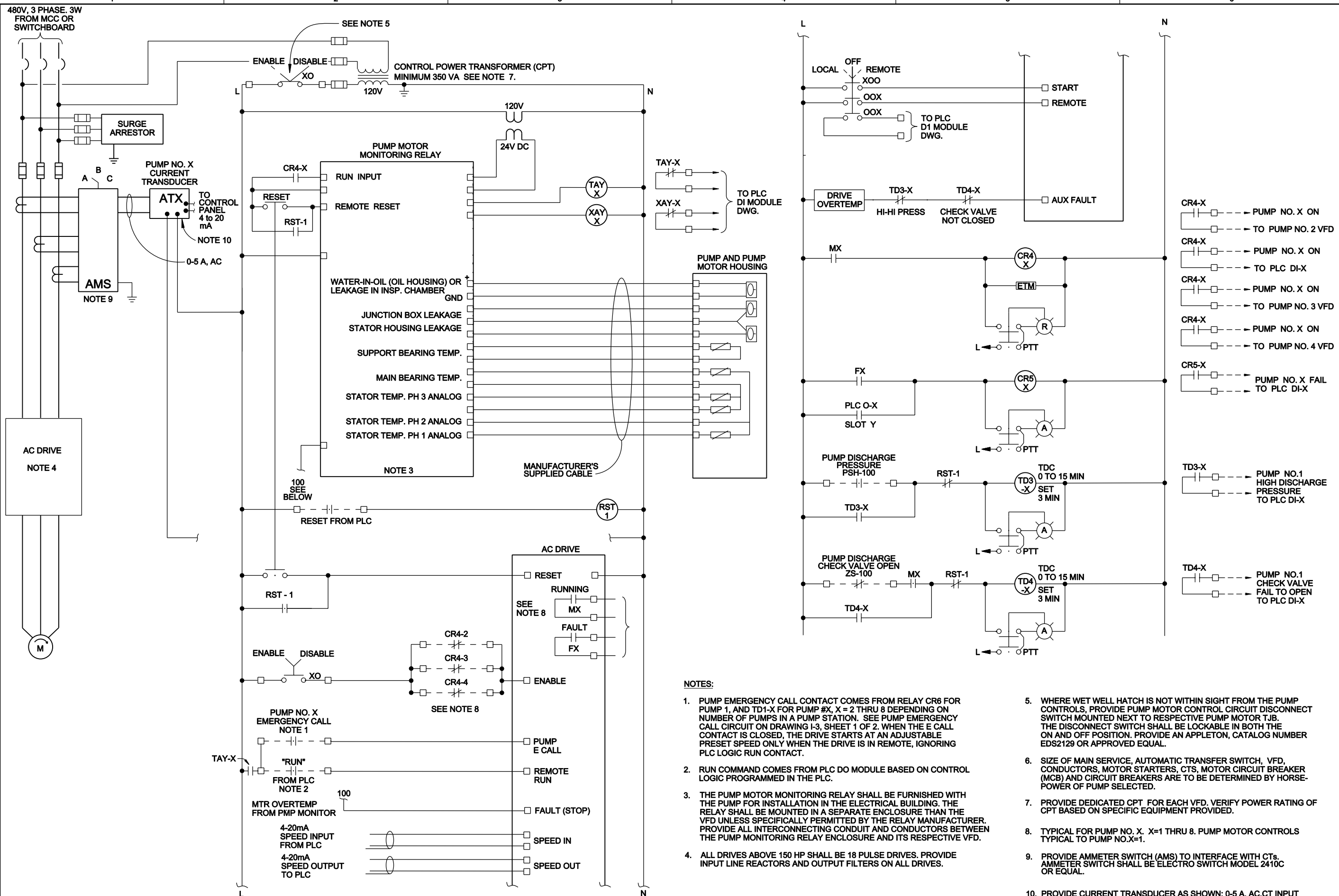

**TYPICAL PUMP VFD CONTROL DIAGRAM 150 HP AND GREATER**

X = 1, 2, 3, 4, 5, 6, 7, 8

**NOTES:**

1. PUMP EMERGENCY CALL CONTACT COMES FROM RELAY CR6 FOR PUMP 1, AND TD1-X FOR PUMP #X, X = 2 THRU 8 DEPENDING ON NUMBER OF PUMPS IN A PUMP STATION. SEE PUMP EMERGENCY CALL CIRCUIT ON DRAWING I-3, SHEET 1 OF 2. WHEN THE E CALL CONTACT IS CLOSED, THE DRIVE STARTS AT AN ADJUSTABLE PRESET SPEED ONLY WHEN THE DRIVE IS IN REMOTE, IGNORING PLC LOGIC RUN CONTACT.
2. RUN COMMAND COMES FROM PLC DO MODULE BASED ON CONTROL LOGIC PROGRAMMED IN THE PLC.
3. THE PUMP MOTOR MONITORING RELAY SHALL BE FURNISHED WITH THE PUMP FOR INSTALLATION IN THE ELECTRICAL BUILDING. THE RELAY SHALL BE MOUNTED IN A SEPARATE ENCLOSURE THAN THE VFD UNLESS SPECIFICALLY PERMITTED BY THE RELAY MANUFACTURER. PROVIDE ALL INTERCONNECTING CONDUIT AND CONDUCTORS BETWEEN THE PUMP MONITORING RELAY ENCLOSURE AND ITS RESPECTIVE VFD.
4. ALL DRIVES ABOVE 150 HP SHALL BE 18 PULSE DRIVES. PROVIDE INPUT LINE REACTORS AND OUTPUT FILTERS ON ALL DRIVES.
5. WHERE WET WELL HATCH IS NOT WITHIN SIGHT FROM THE PUMP MOTOR CONTROLS, PROVIDE PUMP MOTOR CONTROL DISCONNECT SWITCH MOUNTED NEXT TO RESPECTIVE PUMP MOTOR T.J.B. THE DISCONNECT SWITCH SHALL BE LOCKABLE IN BOTH THE ON AND OFF POSITION. PROVIDE AN APPLETON, CATALOG NUMBER EDS2129 OR APPROVED EQUAL.
6. SIZE OF MAIN SERVICE, AUTOMATIC TRANSFER SWITCH, VFD, CONDUCTORS, MOTOR STARTERS, CTS, MOTOR CIRCUIT BREAKER (MCB) AND CIRCUIT BREAKERS ARE TO BE DETERMINED BY HORSE-POWER OF PUMP SELECTED.
7. PROVIDE DEDICATED CPT FOR EACH VFD. VERIFY POWER RATING OF CPT BASED ON SPECIFIC EQUIPMENT PROVIDED.
8. TYPICAL FOR PUMP NO. X. X=1 THRU 8. PUMP MOTOR CONTROLS TYPICAL TO PUMP NO.X=1.
9. PROVIDE AMMETER SWITCH (AMS) TO INTERFACE WITH CTs. AMMETER SWITCH SHALL BE ELECTRO SWITCH MODEL 2410C OR EQUAL.
10. PROVIDE CURRENT TRANSDUCER AS SHOWN; 0-5 A, AC, CT INPUT AND 4-20 MA OUTPUT.

**CH2MHILL**

EXAMPLE  
TYPE IIIB PUMP STATION  
VFD CONTROL WIRING DIAGRAM

VERIFY SCALE	
BAR IS ONE INCH ON ORIGINAL DRAWING.	
DATE	MAY 2012
PROJ	350589
DWG	E-3A
SHEET	

NO.	1	DATE	09/2010	DR	J O'CONNOR
DSGN				CHK	J EFAW
REVISION				APVD	J BALDWIN
UPDATED DESIGN REQUIREMENTS				BY	PK

CITY OF BATON ROUGE  
PARISH OF EAST BATON ROUGE  
DEPARTMENT OF PUBLIC WORKS  
BATON ROUGE, LOUISIANA

REUSE OF DOCUMENTS: THIS DOCUMENT, AND THE IDEAS AND DESIGNS INCORPORATED HEREIN, AS AN INSTRUMENT OF PROFESSIONAL SERVICE, IS THE PROPERTY OF CH2M HILL AND IS NOT TO BE USED, IN WHOLE OR IN PART, FOR ANY OTHER PROJECT WITHOUT THE WRITTEN AUTHORIZATION OF CH2M HILL. © CH2M HILL 2004. ALL RIGHTS RESERVED.

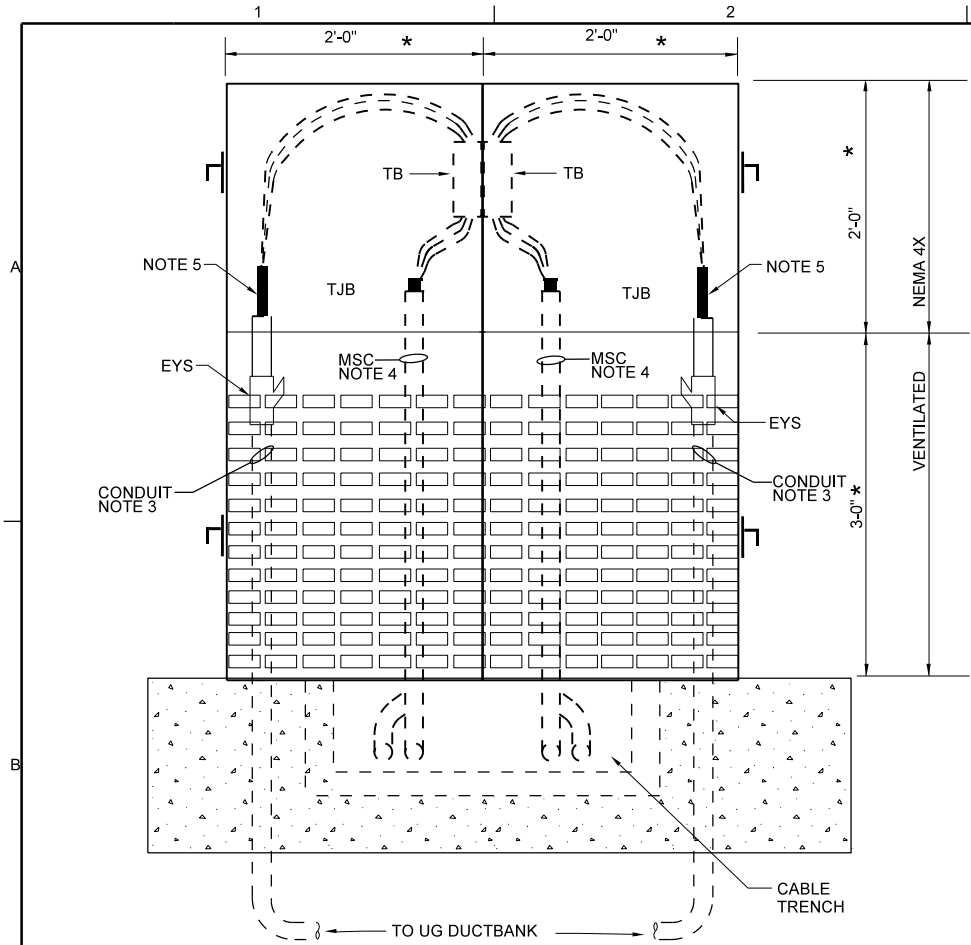

**A** TYPICAL SECTION  
NTS

\* ALL DIMENSIONS ARE FOR GUIDANCE ONLY.  
CUSTOM DESIGN TJB FOR EACH APPLICATION.

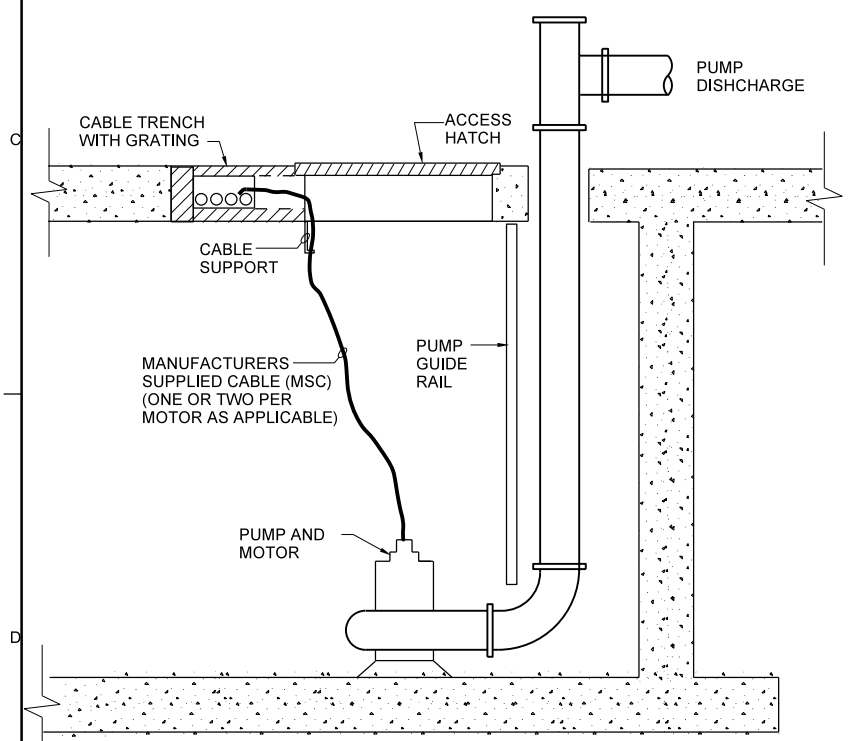

**B** TYPICAL SECTION  
NTS

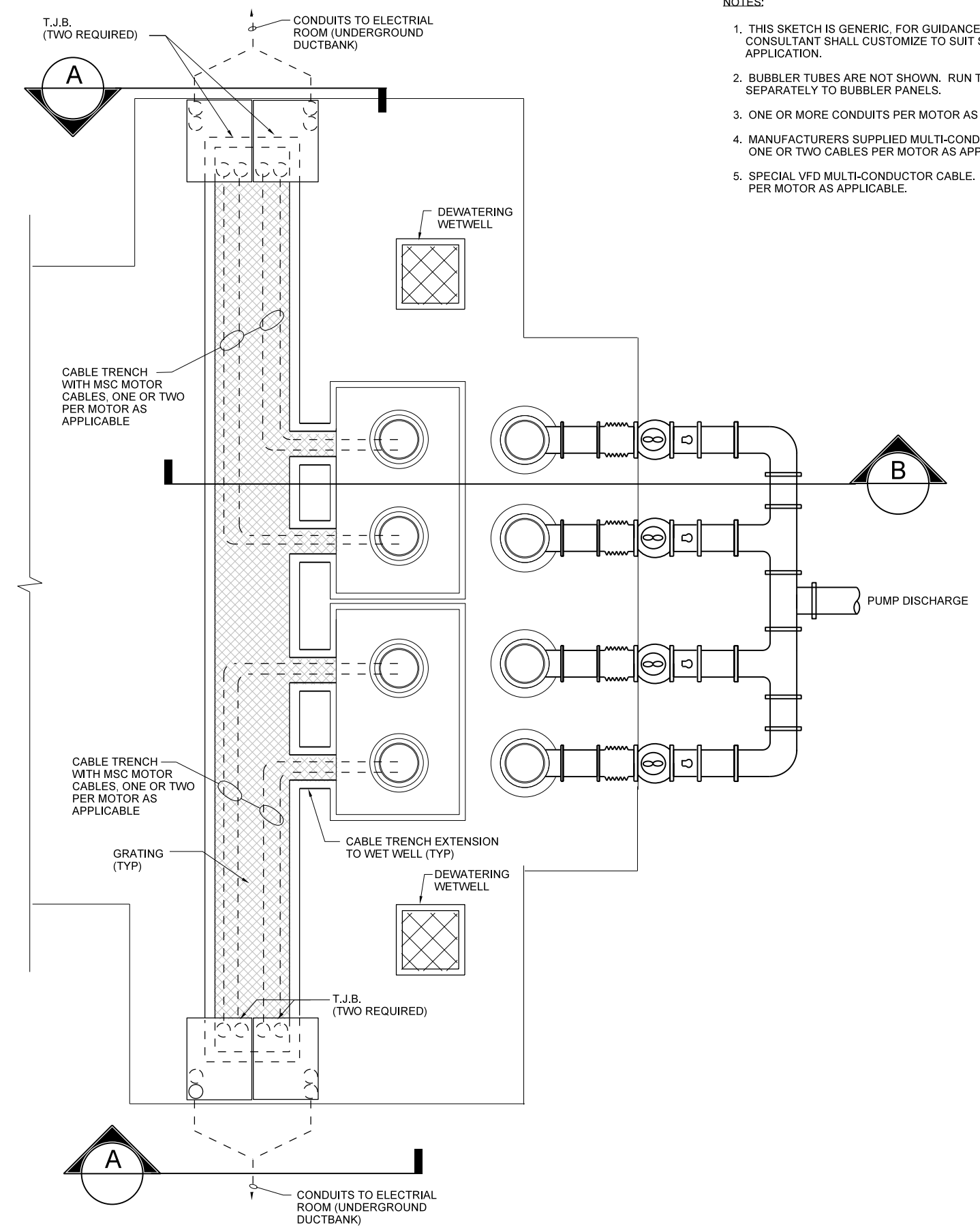

**PUMP STATION PLAN**  
NTS

- NOTES:
1. THIS SKETCH IS GENERIC, FOR GUIDANCE ONLY. CONSULTANT SHALL CUSTOMIZE TO SUIT SPECIFIC APPLICATION.
  2. BUBBLER TUBES ARE NOT SHOWN. RUN THESE TUBES SEPARATELY TO BUBBLER PANELS.
  3. ONE OR MORE CONDUITS PER MOTOR AS APPLICABLE.
  4. MANUFACTURERS SUPPLIED MULTI-CONDUCTOR CABLE. ONE OR TWO CABLES PER MOTOR AS APPLICABLE.
  5. SPECIAL VFD MULTI-CONDUCTOR CABLE. ONE OR TWO PER MOTOR AS APPLICABLE.

<p><b>CH2MHILL</b></p> <p>EXAMPLE RECOMMENDED TJB AND CABLE TRENCH LAYOUT FOR TYPE III PUMP STATIONS</p>		CITY OF BATON ROUGE		PARISH OF EAST BATON ROUGE		DEPARTMENT OF PUBLIC WORKS		BATON ROUGE, LOUISIANA	
		NO. 1	DATE 09/2010	DR J. O'CONNOR	CHK J. LEFAY	BY APVD J. BALDWIN	PK	APVD	
VERIFY SCALE		BAR IS ONE INCH ON ORIGINAL DRAWING.							
DATE	MAY 1012								
PROJ	350589								
DWG	E-4								
SHEET									

**Attachment D**  
**Example Instrumentation and Control Drawings**

---

# ATTACHMENT "D"

**CH2MHILL**

EXAMPLE  
PROGRAM PUMP STATIONS (PDP)  
[THREE OR MORE PUMPS]  
ATTACHMENT "D"

CITY OF BATON ROUGE  
PARISH OF EAST BATON ROUGE  
DEPARTMENT OF PUBLIC WORKS  
BATON ROUGE, LOUISIANA

1	09/2010
DSGN NO.	DATE

J O'CONNOR	DR	J EFAW	CHK	J BALDWIN	APVD
UPDATED DESIGN REQUIREMENTS			REVISION	PK	BY

VERIFY SCALE	
BAR IS ONE INCH ON ORIGINAL DRAWING.	
DATE	MAY 2012
PROJ	350589
DWG	I-0
SHEET	

REUSE OF DOCUMENTS: THIS DOCUMENT AND THE IDEAS AND DESIGNS INCORPORATED HEREIN AS AN INSTRUMENT OF PROFESSIONAL SERVICE IS THE PROPERTY OF CH2M HILL AND IS NOT TO BE USED, IN WHOLE OR IN PART, FOR ANY OTHER PROJECT WITHOUT THE WRITTEN AUTHORIZATION OF CH2M HILL. © CH2M HILL 2004. ALL RIGHTS RESERVED.

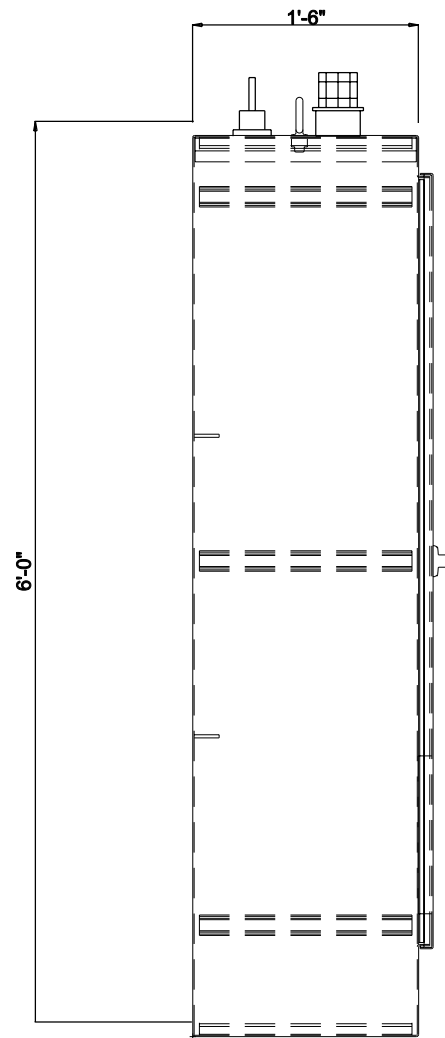

**CONTROL PANEL  
SIDE VIEW  
NOTE 9**

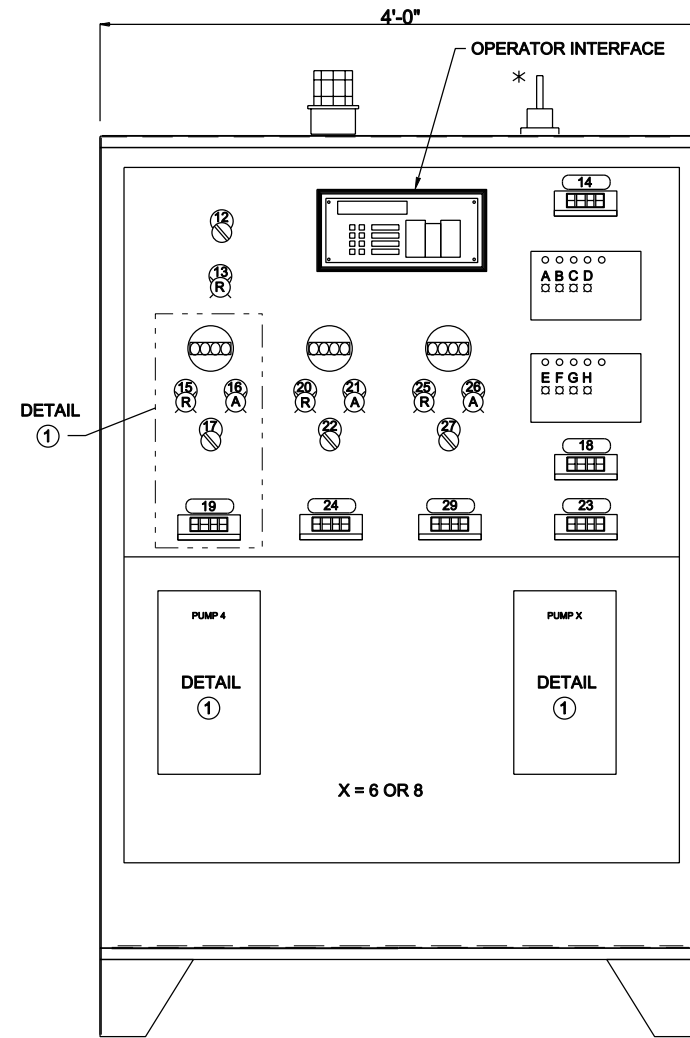

**CONTROL PANEL INNER DEADFRONT DOOR  
NOTE 9**

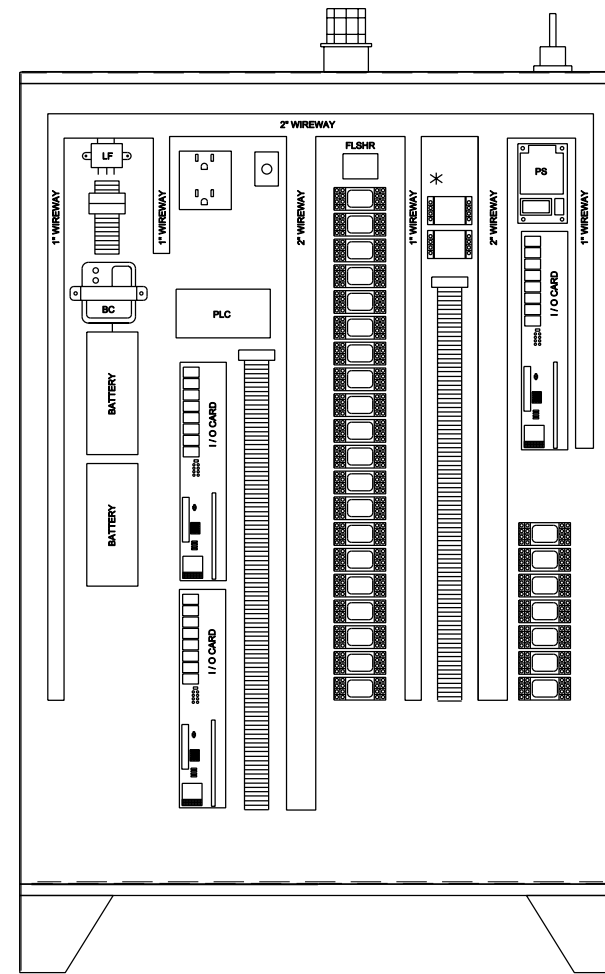

**CONTROL PANEL  
BACKPAN LAYOUT  
(SHOWN WITH ALL DOORS REMOVED)**

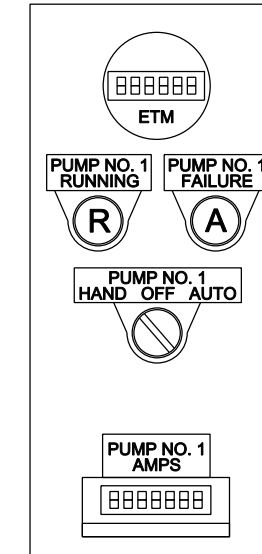

**DETAIL  
NTS 1**

NAMEPLATE SCHEDULE		
TAG NO.	TYPE	INSCRIPTION
12	RING	AREA LIGHT HAND OFF AUTO
13	RING	SILENCE
14	PLATE	DISCHARGE PRESSURE
15	RING	PUMP No. 1 RUNNING
16	RING	PUMP No. 1 FAILURE
17	RING	PUMP No. 1 HAND OFF AUTO
18	PLATE	PUMP STATION FLOW
19	PLATE	PUMP No. 1 AMPS
20	RING	PUMP No. 2 RUNNING
21	RING	PUMP No. 2 FAILURE
22	RING	PUMP No. 2 HAND OFF AUTO
23	PLATE	WET WELL LEVEL
24	PLATE	PUMP No. 2 AMPS

NAMEPLATE SCHEDULE		
TAG NO.	TYPE	INSCRIPTION
25	RING	PUMP No. 3 RUNNING
26	RING	PUMP No. 3 FAILURE
27	RING	PUMP No. 3 HAND OFF AUTO
29	PLATE	PUMP No. 3 AMPS
A	PLATE	HIGH LEVEL FLOAT
B	PLATE	LOW LEVEL FLOAT
E	PLATE	PUMP No. 1 MOISTURE
F	PLATE	PUMP No. 2 MOISTURE
G	PLATE	PUMP No. 3 MOISTURE

**NOTES:**

- CONSTRUCTION SHALL BE GASKETED NEMA 1 FOR ALL INDOOR CONDITIONED ROOMS AND NEMA 4X FOR OUTDOOR PANELS.
- FOR INDOOR CONDITIONED ROOMS: EXTERIOR 12 GA. STEEL SEAMS CONTINUOUSLY WELDED AND GROUND SMOOTH. NO HOLES OR KNOCKOUTS. INTERIOR STIFFENERS WHERE REQUIRED.
- PROVIDE PHENOLIC NAMEPLATES AS REQUIRED.
- CONTROL WIRING SHALL BE MARKED AT BOTH ENDS BY PERMANENT WIRE MARKERS.
- A PLASTIC COATED WIRING DIAGRAM SHALL BE ATTACHED TO THE INSIDE OF THE FRONT DOOR.
- ENCLOSURE WILL BE FACTORY WIRED AND CONFORM TO NEMA STANDARDS.
- WHERE REQUIRED, INTRINSICALLY SAFE WIRING SHALL BE INSTALLED PER NEC ARTICLE 504 AND IEEE AND UL-508 REQUIREMENTS.
- THE CONTROL PANEL ASSEMBLY SHALL BE UL-508 LISTED.
- EXAMPLE DIMENSIONS SHOWN, ENGINEER TO SIZE CONTROL PANEL PER THE REQUIREMENTS OF THE INDIVIDUAL PUMP STATION.
- FOR GENERAL CONSTRUCTION NOTES, SEE DPW PLAN NO. 805-05.

\* ITEM FURNISHED BY OTHERS, TO BE INSTALLED BY CONTRACTOR.

**PUMP STATION # \_\_\_\_\_  
CONTROL PANEL**

MANUFACTURER'S NAME		I.D. #		
PHONE NUMBER		SERIAL #		
ADDRESS, LOCATION				
<b>INDUSTRIAL CONTROL PANEL</b>				
VOLTAGE	PHASE	WIRES	MAINS AMPERES	HZ
120	1	3	—	60
SUITABLE FOR USE ON A CIRCUIT CAPABLE OF DELIVERING NOT MORE THAN:				
AMPERES		AT	VOLTAGE	
12,000 RMS SYM			120 V	
METER SOCKET RATING			A. CONT.	
ENCLOSURE TYPE			NOTE 1	

**EXAMPLE EXTERIOR NAMEPLATES**

**CH2MHILL**  
EXAMPLE  
CONTROL PANEL  
(TYPE IIIA & TYPE IIIB STATION)

VERIFY SCALE	
BAR IS ONE INCH ON ORIGINAL DRAWING.	
DATE	MAY 2012
PROJ	350589
DWG	I-1
SHEET	

NO.	1	DATE	09/2010	DR	J O'CONNOR	CHK	J EFRAW	APVD	J BALDWIN
DSGN									
REVISION									
UPDATED DESIGN REQUIREMENTS									
PK		BY		APVD					



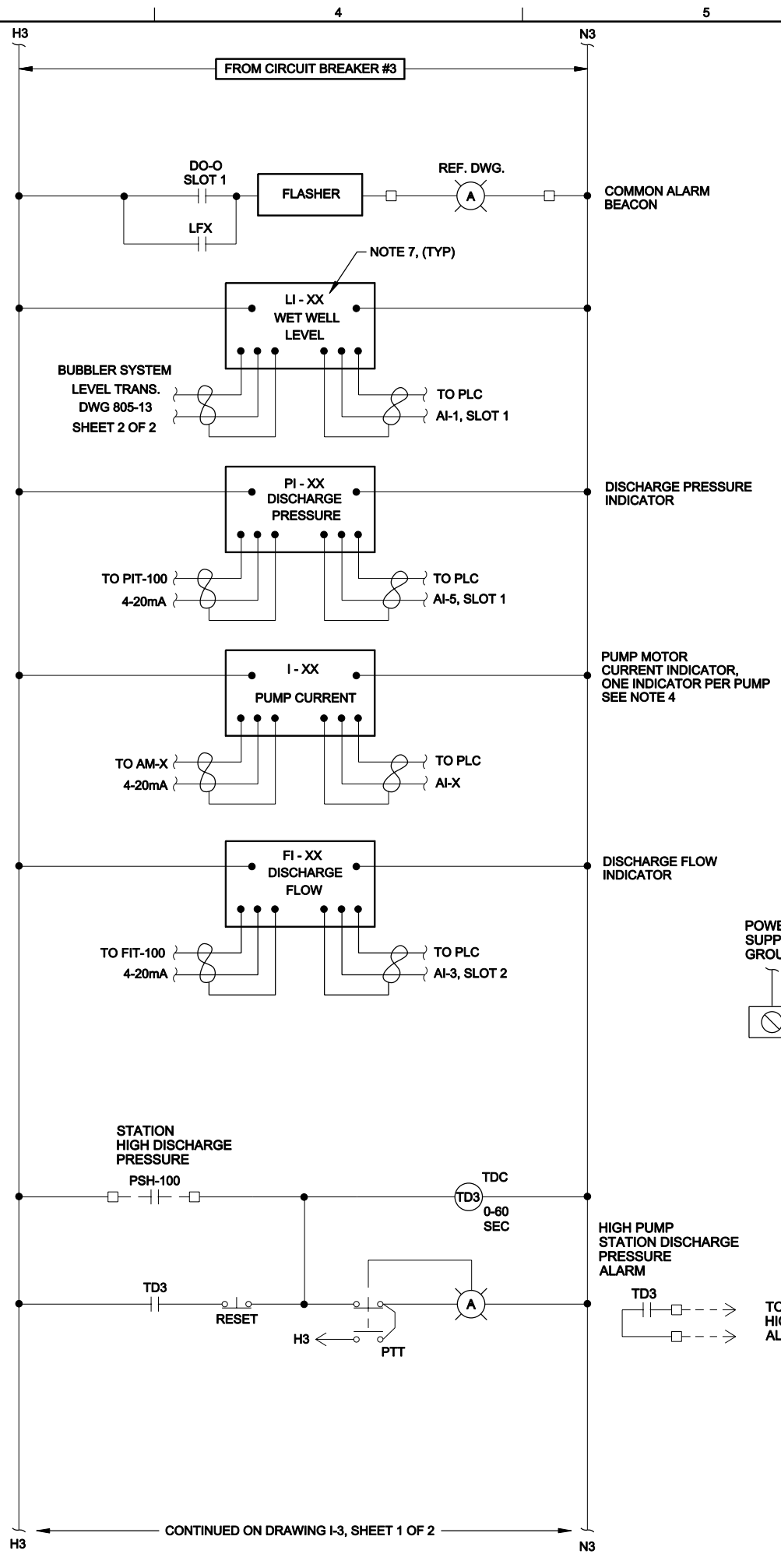
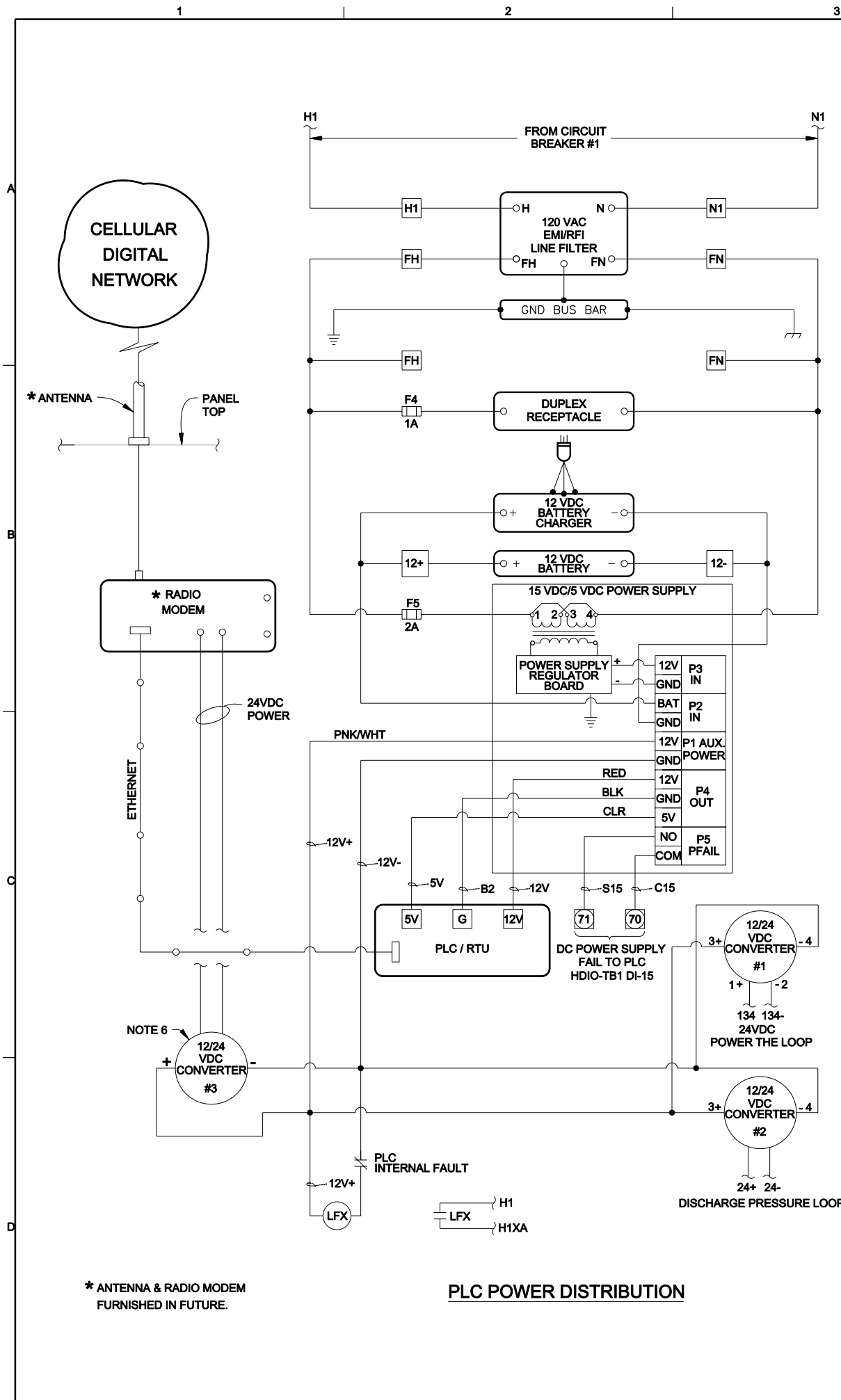

- NOTES:**
1. PROVIDE EITHER A 24VDC BATTERY CHARGER WITH BATTERIES, 24VDC INTEGRATED UPS, OR 120VAC UPS WITH 24VDC POWER SUPPLY MEETING THE REQUIREMENTS OF UL508. PROVIDE MEANS TO TAP 12V DC FROM THE BATTERY SYSTEM AS NEEDED TO POWER THE RADIO MODEM. CHANGE RADIO MODEM POWER SUPPLY WIRING TO SUIT REQUIREMENT.
  2. PROVIDE ADEQUATELY SIZED FUSE FOR ALL DC LOADS.
  3. ITEMS DENOTED WITH AN ASTERISK (\*) ARE FURNISHED BY OTHERS.
  4. NUMBER OF PUMPS IN PUMP STATION VARIES FROM FOUR TO EIGHT. DESIGN CUSTOMIZED WIRING DIAGRAMS FOR EACH PUMP STATION BASED ON NUMBER OF PUMPS.
  5. OPERATOR INTERFACE TO BE INSTALLED ON THE PANEL FRONT DOOR.
  6. CONVERTER #3 IS NOT REQUIRED IF THE RADIO MODEM IS RATED FOR 12VDC INPUT POWER SUPPLY.
  7. ALL INSTRUMENTS AND I/O POINTS SHALL BE TAGGED PER PROGRAM TAGGING REQUIREMENTS.

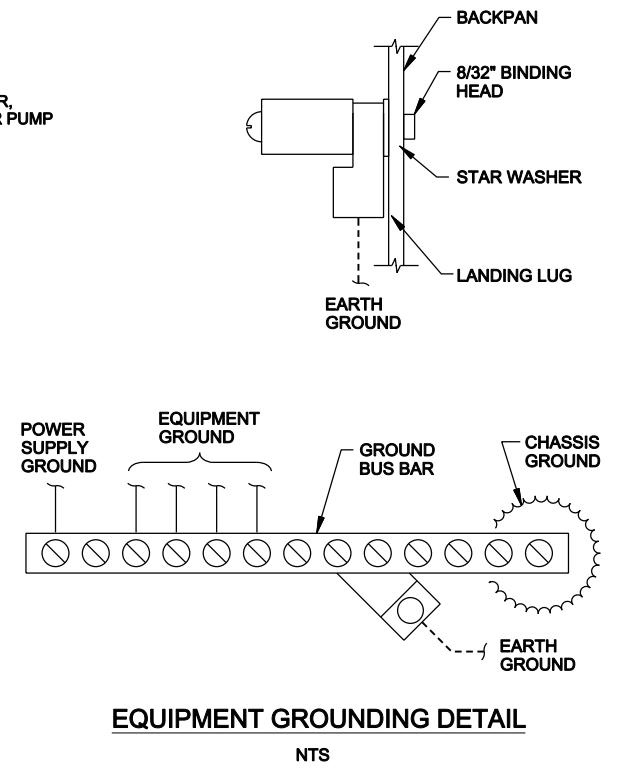

**CH2MHILL**

EXAMPLE

CITY OF BATON ROUGE  
PARISH OF EAST BATON ROUGE  
DEPARTMENT OF PUBLIC WORKS  
BATON ROUGE, LOUISIANA

POWER DISTRIBUTION AND PUMP CONTROL DIAGRAM (TYPE IIIA & IIIB PUMP STATION)

NO.	DATE	DR	REVISION	CHK	BY
		J. O'CONNOR		J. EFRAW	J. BALDWIN

VERIFY SCALE

BAR IS ONE INCH ON ORIGINAL DRAWING.

DATE MAY 2012

PROJ 350589

DWG I-2

SHEET

PROPOSAL

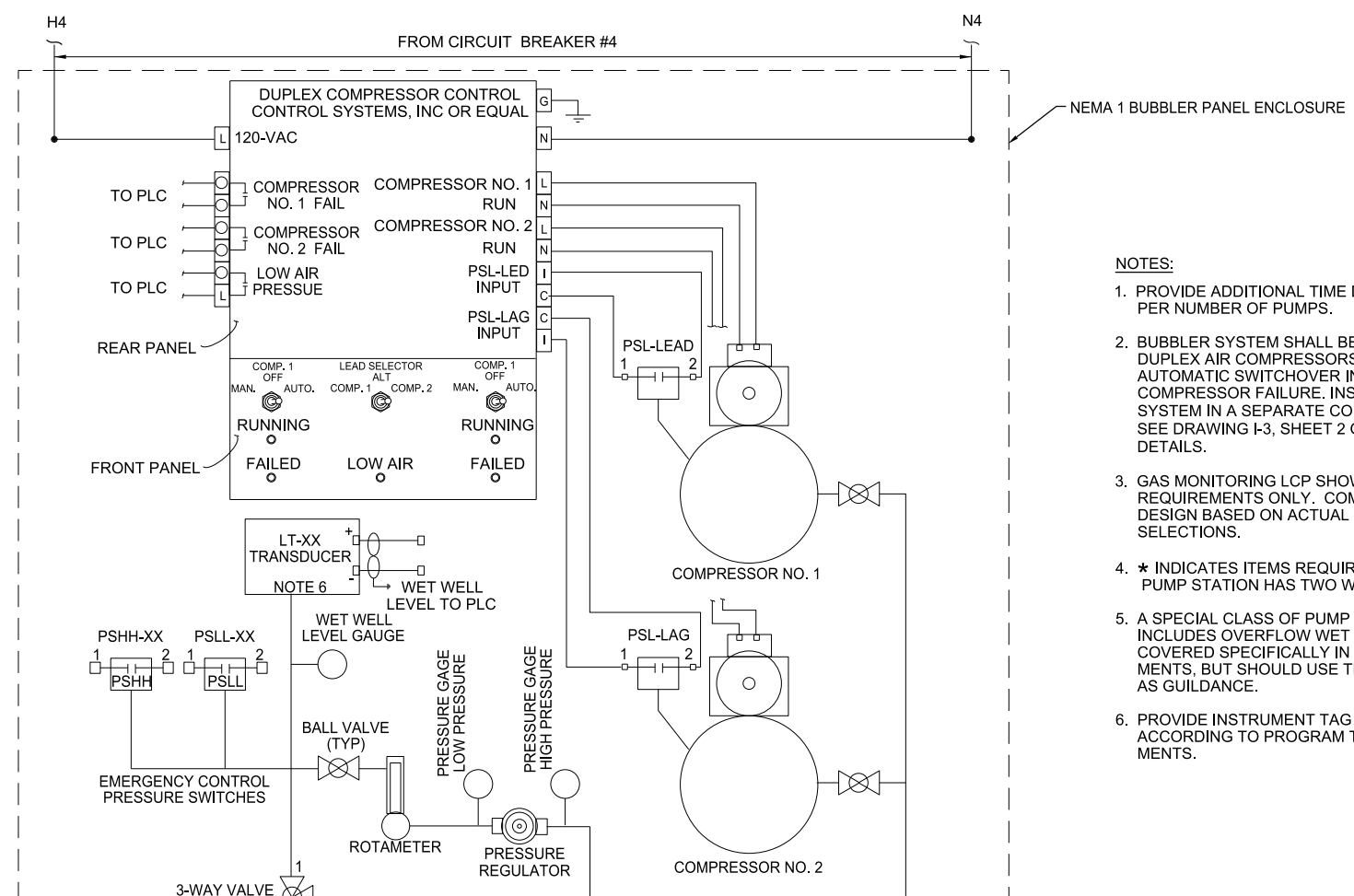

- NOTES:**
1. PROVIDE ADDITIONAL TIME DELAY RELAYS PER NUMBER OF PUMPS.
  2. BUBBLER SYSTEM SHALL BE SUPPLIED WITH DUPLEX AIR COMPRESSORS CONFIGURED FOR AUTOMATIC SWITCHOVER IN THE EVENT OF A COMPRESSOR FAILURE. INSTALL BUBBLER SYSTEM IN A SEPARATE CONTROL PANEL. SEE DRAWING I-3, SHEET 2 OF 2 FOR PANEL DETAILS.
  3. GAS MONITORING LCP SHOWS FUNCTIONAL REQUIREMENTS ONLY. COMPLETE DETAILED DESIGN BASED ON ACTUAL COMPONENT SELECTIONS.
  4. \* INDICATES ITEMS REQUIRED ONLY IF THE PUMP STATION HAS TWO WET WELLS.
  5. A SPECIAL CLASS OF PUMP STATION THAT INCLUDES OVERFLOW WET WELLS ARE NOT COVERED SPECIFICALLY IN THESE REQUIREMENTS, BUT SHOULD USE THESE DOCUMENTS AS GUIDANCE.
  6. PROVIDE INSTRUMENT TAG NUMBERS ACCORDING TO PROGRAM TAGGING REQUIREMENTS.

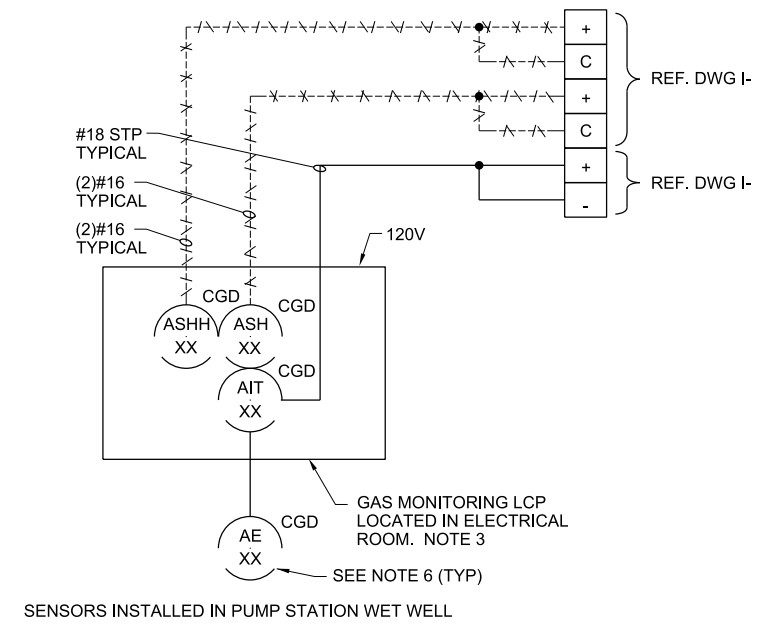
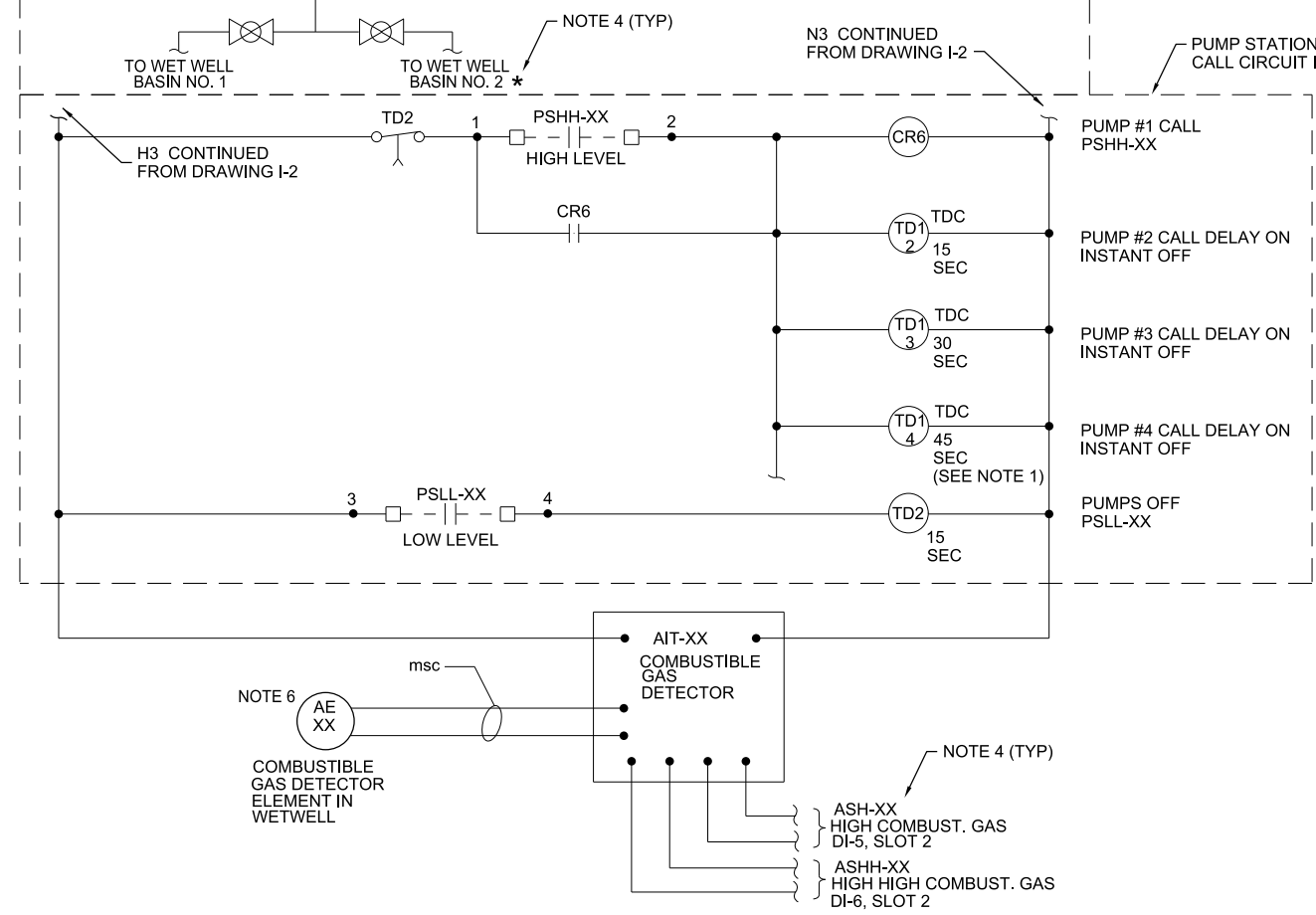

**GAS MONITORING LCP WIRING DIAGRAM**

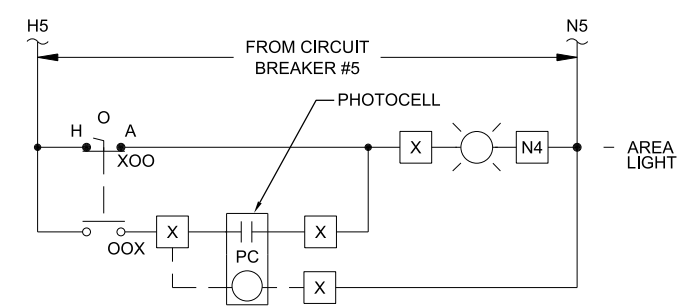

**AREA LIGHTING CONTROLS**

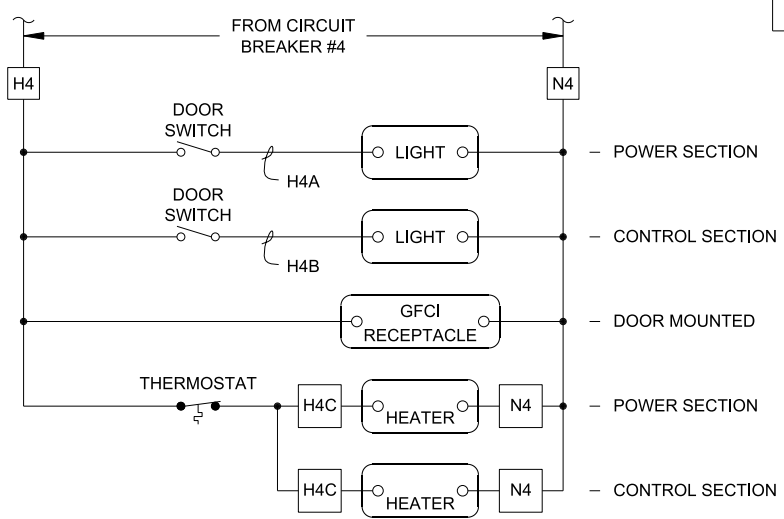

**MISCELLANEOUS WIRING DIAGRAM**

<b>CH2MHILL</b> EXAMPLE PROGRAM PUMP STATION (PDP) TYPE IIIA & IIIB CONTROL-BUBBLER PANEL DETAILS SHT 1/2		CITY OF BATON ROUGE		PARISH OF EAST BATON ROUGE		DEPARTMENT OF PUBLIC WORKS		BATON ROUGE, LOUISIANA	
		DATE	MAY 2012	PROJ	350589	DWG	I-3	SHEET	1 OF 2
VERIFY SCALE		BAR IS ONE INCH ON ORIGINAL DRAWING		DATE		MAY 2012		PROJ	
DATE		MAY 2012		PROJ		350589		DWG	
DWG		I-3		SHEET		1 OF 2		PROPOSAL	

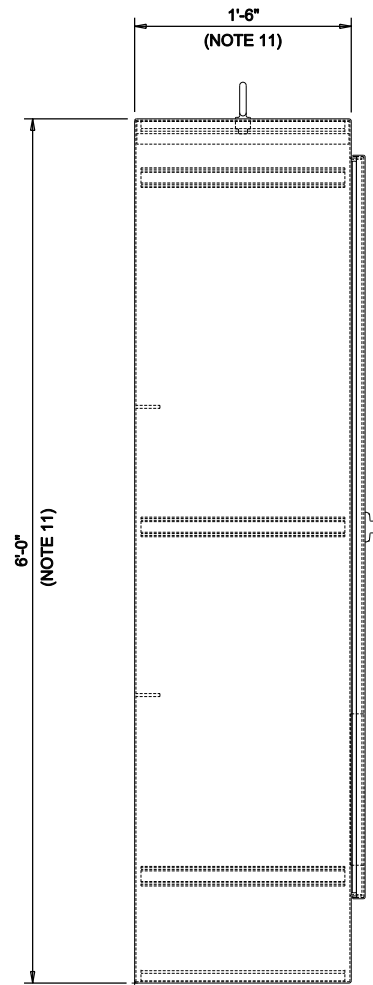

SIDE VIEW

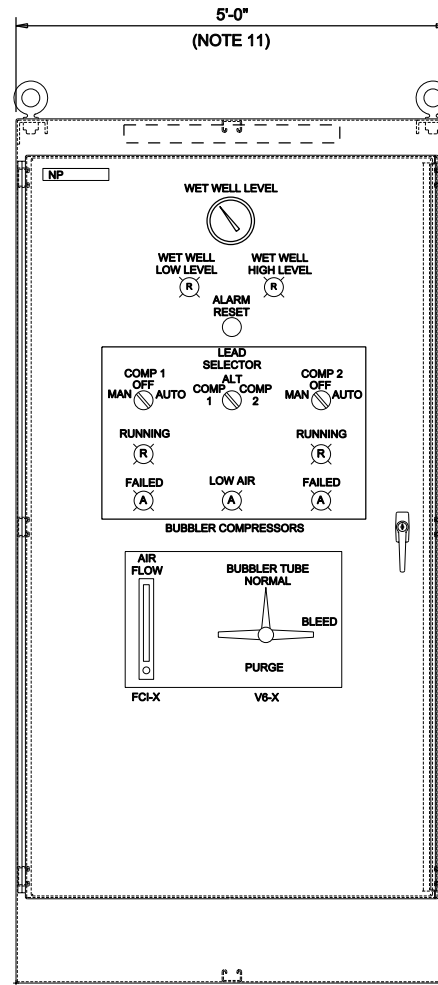

FRONT ELEVATION

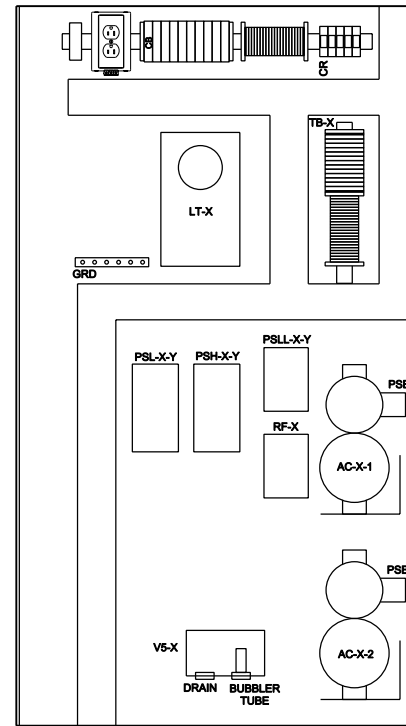

BACK PANEL LAYOUT

TYPICAL AIR BUBBLER SYSTEM ENCLOSURE

MANUFACTURER'S NAME I.D. #  
 PHONE NUMBER SERIAL #  
 ADDRESS, LOCATION

**INDUSTRIAL CONTROL PANEL**

VOLTAGE	PHASE	WIRES	MAINS AMPERES	HZ
120	1	3	-	60

SUITABLE FOR USE ON A CIRCUIT CAPABLE OF DELIVERING NOT MORE THAN:

AMPERES	AT	VOLTAGE
12,000	RMS SYM	120 V

METER SOCKET RATING N/A A. CONT.  
 ENCLOSURE TYPE NOTE 1

**BUBBLER SYSTEM CABINET # X  
 LEVEL CONTROL**

EXAMPLE EXTERIOR NAMEPLATES

- NOTES:
- CONSTRUCTION SHALL BE GASKETED NEMA 1 FOR ALL INDOOR CONDITIONED ROOMS AND NEMA 4X FOR OUTDOOR PANELS.
  - FOR INDOOR CONDITIONED ROOMS: EXTERIOR 12 GA. STEEL. SEAMS CONTINUOUSLY WELDED AND GROUND SMOOTH. NO HOLES OR KNOCKOUTS. INTERIOR STIFFENERS WHERE REQUIRED.
  - FOR OUTDOOR APPLICATIONS PROVIDE 316SS, NEMA 4X PANELS. ALL NUTS, BOLTS, SCREWS, HINGES, LIFTING EYES AND OTHER HARDWARE TO BE 316L STAINLESS STEEL. INCLUDE HEAVY-DUTY THREE-POINT DOOR LATCHING MECHANISM WITH 316L STAINLESS STEEL PADLOCKING HANDLE.
  - PROVIDE PHENOLIC NAMEPLATES AS REQUIRED.
  - CONTROL WIRING SHALL BE MARKED AT BOTH ENDS BY PERMANENT WIRE MARKERS.
  - A PLASTIC COATED WIRING DIAGRAM SHALL BE ATTACHED TO THE INSIDE OF THE FRONT DOOR.
  - ENCLOSURE WILL BE FACTORY WIRED AND CONFORM TO NEMA STANDARDS.
  - INTRINSICALLY SAFE WIRING SHALL BE INSTALLED PER NEC ARTICLE 504 AND IEEE AND UL-508 REQUIREMENTS.
  - ENCLOSURE SHALL BE UL-508 LISTED.
  - REFERENCE DRAWING I-3, SHEET 1 OF 2 FOR CONTROL AND WIRING DETAILS.
  - EXAMPLE DIMENSIONS SHOWN, ENGINEER TO SIZE CONTROL PANEL PER THE REQUIREMENTS OF THE INDIVIDUAL PUMP STATION.

**CH2MHILL**

CITY OF BATON ROUGE  
 PARISH OF EAST BATON ROUGE  
 DEPARTMENT OF PUBLIC WORKS  
 BATON ROUGE, LOUISIANA

EXAMPLE  
 PROGRAM PUMP STATION (PDP)  
 TYPE IIIA & IIIB  
 CONTROL-BUBBLER PANEL DETAILS SHT 2/2

VERIFY SCALE  
 BAR IS ONE INCH ON ORIGINAL DRAWING.

DATE	MAY 2012
PROJ	350589
DWG	I-3
SHEET	2 OF 2

PROPOSAL

REUSE OF DOCUMENTS: THIS DOCUMENT, AND THE IDEAS AND DESIGNS INCORPORATED HEREIN, AS AN INSTRUMENT OF PROFESSIONAL SERVICE, IS THE PROPERTY OF CH2M HILL AND IS NOT TO BE USED, IN WHOLE OR IN PART, FOR ANY OTHER PROJECT WITHOUT THE WRITTEN AUTHORIZATION OF CH2M HILL. © CH2M HILL 2004. ALL RIGHTS RESERVED.

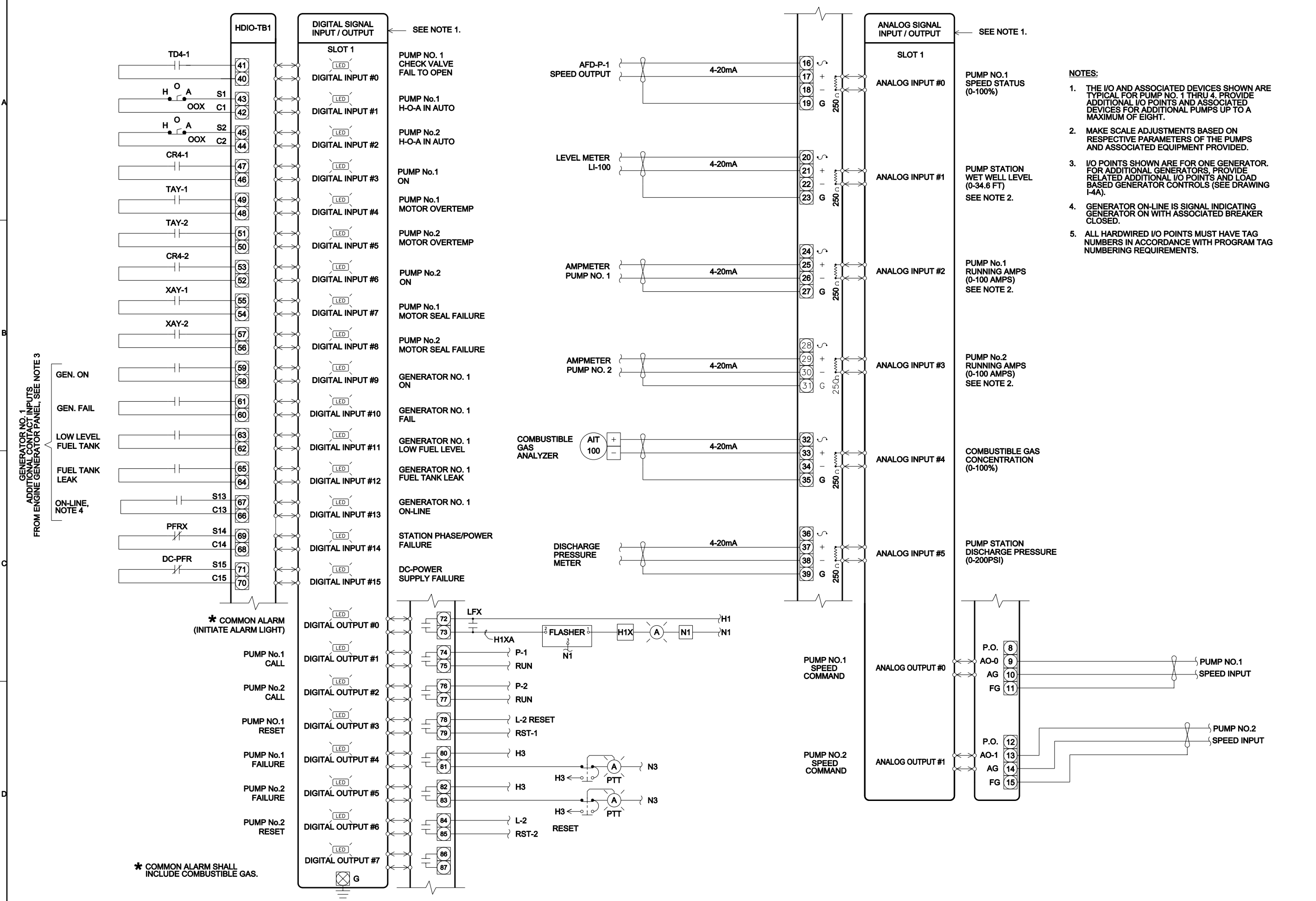

**CH2MHILL**

EXAMPLE  
PROGRAM PUMP STATION (PDP)  
[TYPE IIIA & IIIB]  
PLC I/O WIRING DIAGRAM SHT. 1

CITY OF BATON ROUGE  
PARISH OF EAST BATON ROUGE  
DEPARTMENT OF PUBLIC WORKS  
BATON ROUGE, LOUISIANA

NO. 1 DATE 09/2010

REVISION REQUIREMENTS

PK BY APVD

DR J O'CONNOR

CHK J EFRAW

APVD J BALDWIN

VERIFY SCALE  
BAR IS ONE INCH ON ORIGINAL DRAWING.

DATE MAY 2012  
PROJ 350589  
DWG I-4  
SHEET

REUSE OF DOCUMENTS: THIS DOCUMENT, AND THE IDEAS AND DESIGNS INCORPORATED HEREIN, AS AN INSTRUMENT OF PROFESSIONAL SERVICE, IS THE PROPERTY OF CH2M HILL AND IS NOT TO BE USED, IN WHOLE OR IN PART, FOR ANY OTHER PROJECT WITHOUT THE WRITTEN AUTHORIZATION OF CH2M HILL. © CH2M HILL 2004. ALL RIGHTS RESERVED.

PROPOSAL

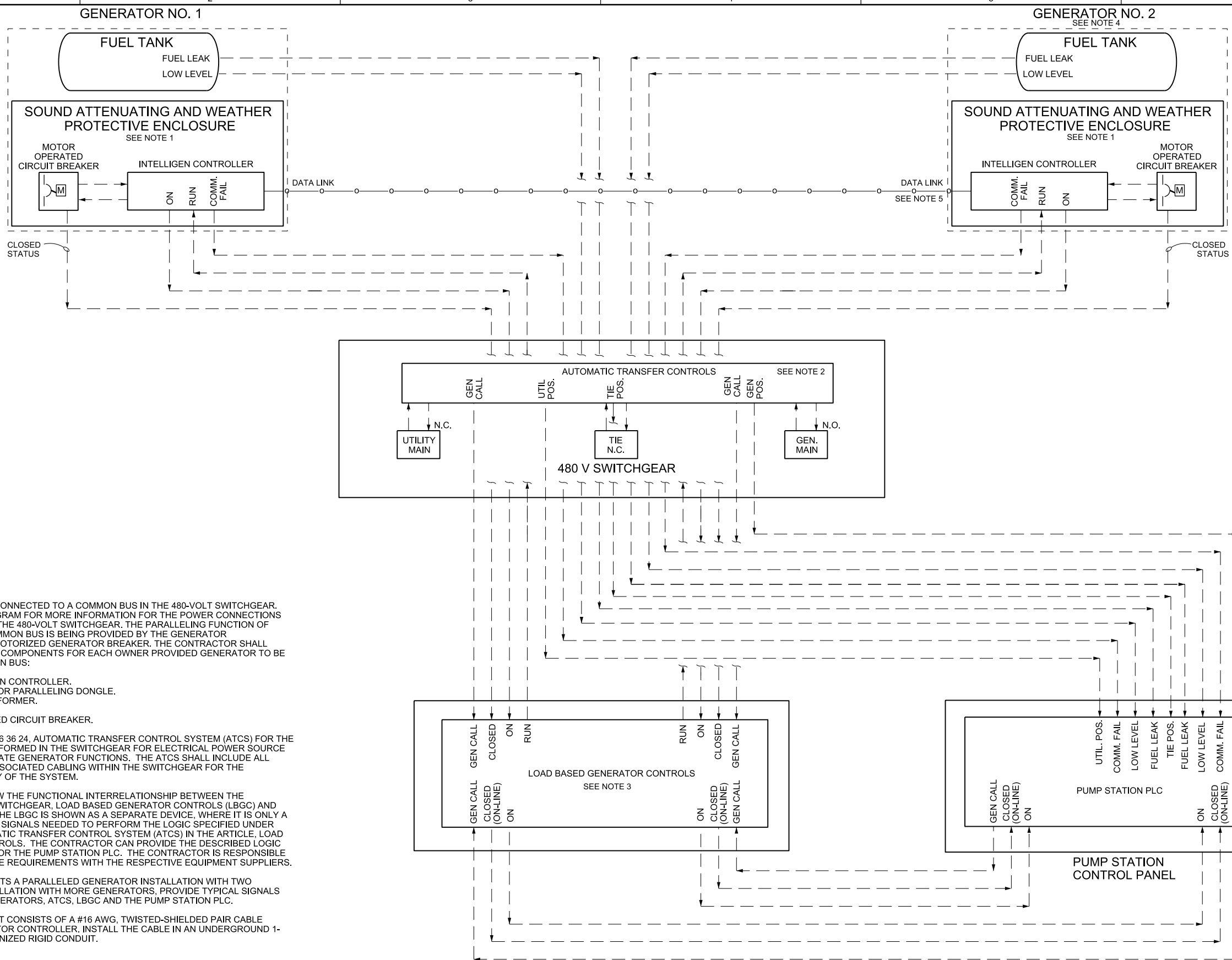

- NOTES:
- BOTH GENERATORS ARE CONNECTED TO A COMMON BUS IN THE 480-VOLT SWITCHGEAR. SEE THE SINGLE LINE DIAGRAM FOR MORE INFORMATION FOR THE POWER CONNECTIONS OF THE GENERATORS TO THE 480-VOLT SWITCHGEAR. THE PARALLELING FUNCTION OF GENERATORS TO THE COMMON BUS IS BEING PROVIDED BY THE GENERATOR CONTROLLERS AND THE MOTORIZED GENERATOR BREAKER. THE CONTRACTOR SHALL PROVIDE THE FOLLOWING COMPONENTS FOR EACH OWNER PROVIDED GENERATOR TO BE PARALLELED TO A COMMON BUS:
    - A. BALDOR, INTELLIGEN CONTROLLER.
    - B. BALDOR, GENERATOR PARALLELING DONGLE.
    - C. BALDOR, IG TRANSFORMER.
    - D. BALDOR, IG AVR1.
    - E. BALDOR, MOTORIZED CIRCUIT BREAKER.
  - REFER TO THE SECTION 26 36 24, AUTOMATIC TRANSFER CONTROL SYSTEM (ATCS) FOR THE SPECIFIC FUNCTIONS PERFORMED IN THE SWITCHGEAR FOR ELECTRICAL POWER SOURCE SELECTION AND COORDINATE GENERATOR FUNCTIONS. THE ATCS SHALL INCLUDE ALL SENSING DEVICES AND ASSOCIATED CABLING WITHIN THE SWITCHGEAR FOR THE SPECIFIED FUNCTIONALITY OF THE SYSTEM.
  - THIS DIAGRAM IS TO SHOW THE FUNCTIONAL INTERRELATIONSHIP BETWEEN THE GENERATORS, TYPE IIIB SWITCHGEAR, LOAD BASED GENERATOR CONTROLS (LBGC) AND THE PUMP STATION PLC. THE LBGC IS SHOWN AS A SEPARATE DEVICE, WHERE IT IS ONLY A REPRESENTATION OF THE SIGNALS NEEDED TO PERFORM THE LOGIC SPECIFIED UNDER SECTION 26 36 24, AUTOMATIC TRANSFER CONTROL SYSTEM (ATCS) IN THE ARTICLE, LOAD BASED GENERATOR CONTROLS. THE CONTRACTOR CAN PROVIDE THE DESCRIBED LOGIC WITHIN EITHER THE ATCS OR THE PUMP STATION PLC. THE CONTRACTOR IS RESPONSIBLE FOR COORDINATING THESE REQUIREMENTS WITH THE RESPECTIVE EQUIPMENT SUPPLIERS.
  - THIS DIAGRAM REPRESENTS A PARALLELED GENERATOR INSTALLATION WITH TWO GENERATORS. FOR INSTALLATION WITH MORE GENERATORS, PROVIDE TYPICAL SIGNALS BETWEEN INDIVIDUAL GENERATORS, ATCS, LBGC AND THE PUMP STATION PLC.
  - PROVIDE A DATALINK THAT CONSISTS OF A #16 AWG, TWISTED-SHIELDED PAIR CABLE BETWEEN EACH GENERATOR CONTROLLER. INSTALL THE CABLE IN AN UNDERGROUND 1-INCH PVC-COATED GALVANIZED RIGID CONDUIT.

**MAJOR CONTROL SIGNAL INTERFACING FOR  
UTILITY / GENERATOR SOURCE TRANSFER SCHEME - TWO GENERATORS**

<b>CH2MHILL</b>		CITY OF BATON ROUGE PARISH OF EAST BATON ROUGE DEPARTMENT OF PUBLIC WORKS BATON ROUGE, LOUISIANA	
EXAMPLE MAJOR CONTROL SIGNAL FOR UTILITY / GENERATOR SOURCE TRANSFER SCHEME - TWO GENERATORS		REVISION CHK J. BALDWIN DR J. O'CONNOR	
NO.	DATE	BY	APVD
VERIFY SCALE BAR IS ONE INCH ON ORIGINAL DRAWING.			
DATE	MAY 2012	PROJ	350589
DWG	I-4A	SHEET	

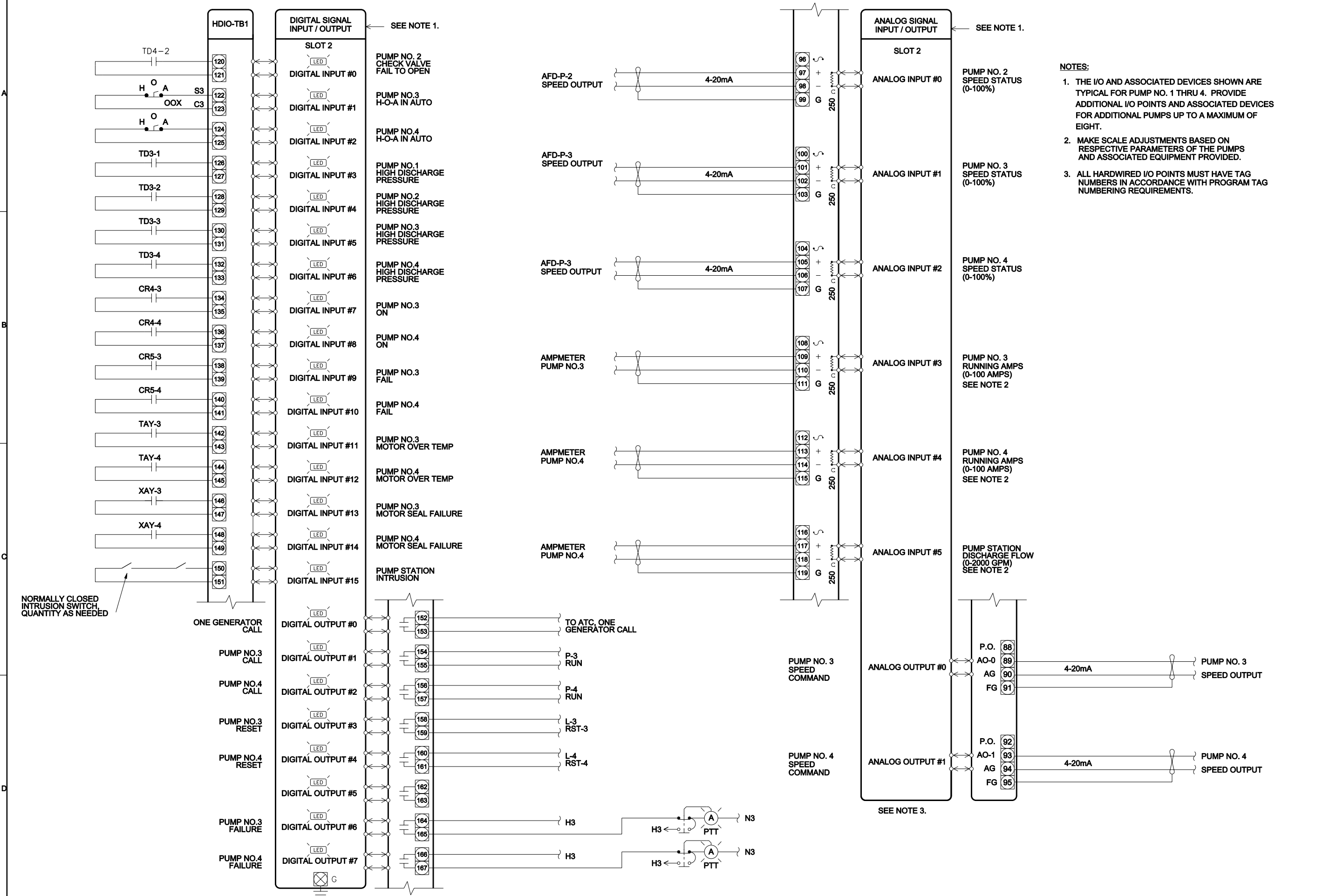

- NOTES:**
1. THE I/O AND ASSOCIATED DEVICES SHOWN ARE TYPICAL FOR PUMP NO. 1 THRU 4. PROVIDE ADDITIONAL I/O POINTS AND ASSOCIATED DEVICES FOR ADDITIONAL PUMPS UP TO A MAXIMUM OF EIGHT.
  2. MAKE SCALE ADJUSTMENTS BASED ON RESPECTIVE PARAMETERS OF THE PUMPS AND ASSOCIATED EQUIPMENT PROVIDED.
  3. ALL HARDWIRED I/O POINTS MUST HAVE TAG NUMBERS IN ACCORDANCE WITH PROGRAM TAG NUMBERING REQUIREMENTS.

**CH2MHILL**

EXAMPLE  
**PROGRAM PUMP STATION (PDP)**  
 [TYPE IIIA & IIIB]  
**PLC I/O WIRING DIAGRAM SHT. 2**

VERIFY SCALE  
 BAR IS ONE INCH ON ORIGINAL DRAWING.

DATE	MAY 2012
PROJ	350589
DWG	I-5
SHEET	

PK	BY	APVD
UPDATED DESIGN REQUIREMENTS		
NO.	DATE	DR
1	09/2010	J O'CONNOR
REVISION	CHK	APVD
J EFAM	J BALDWIN	

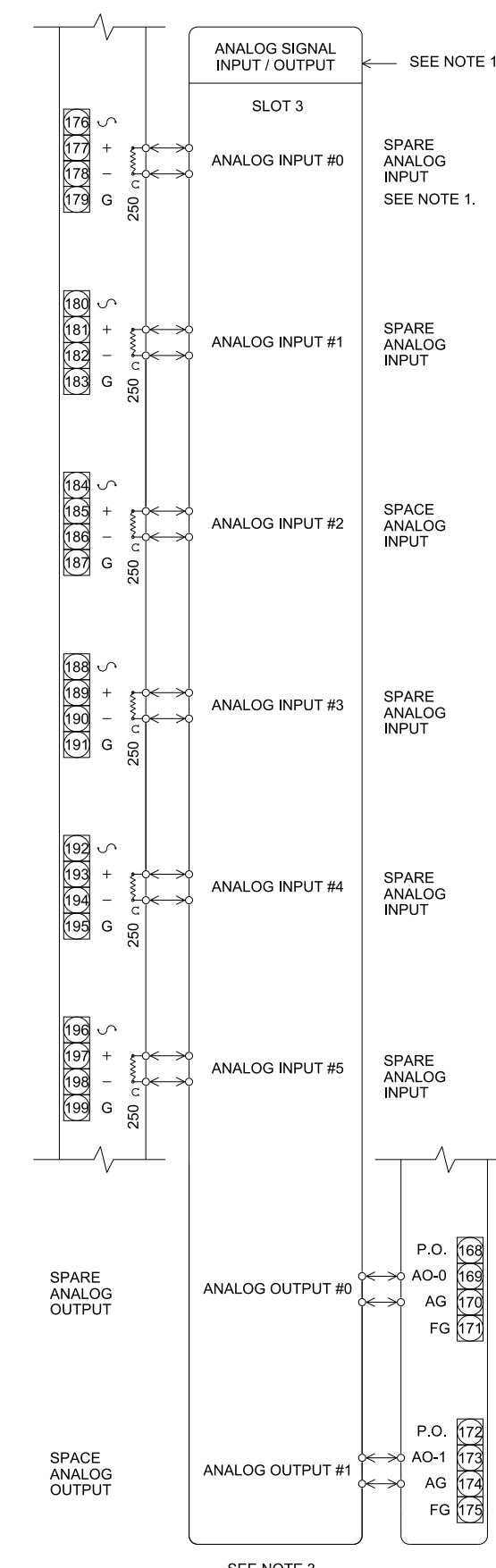
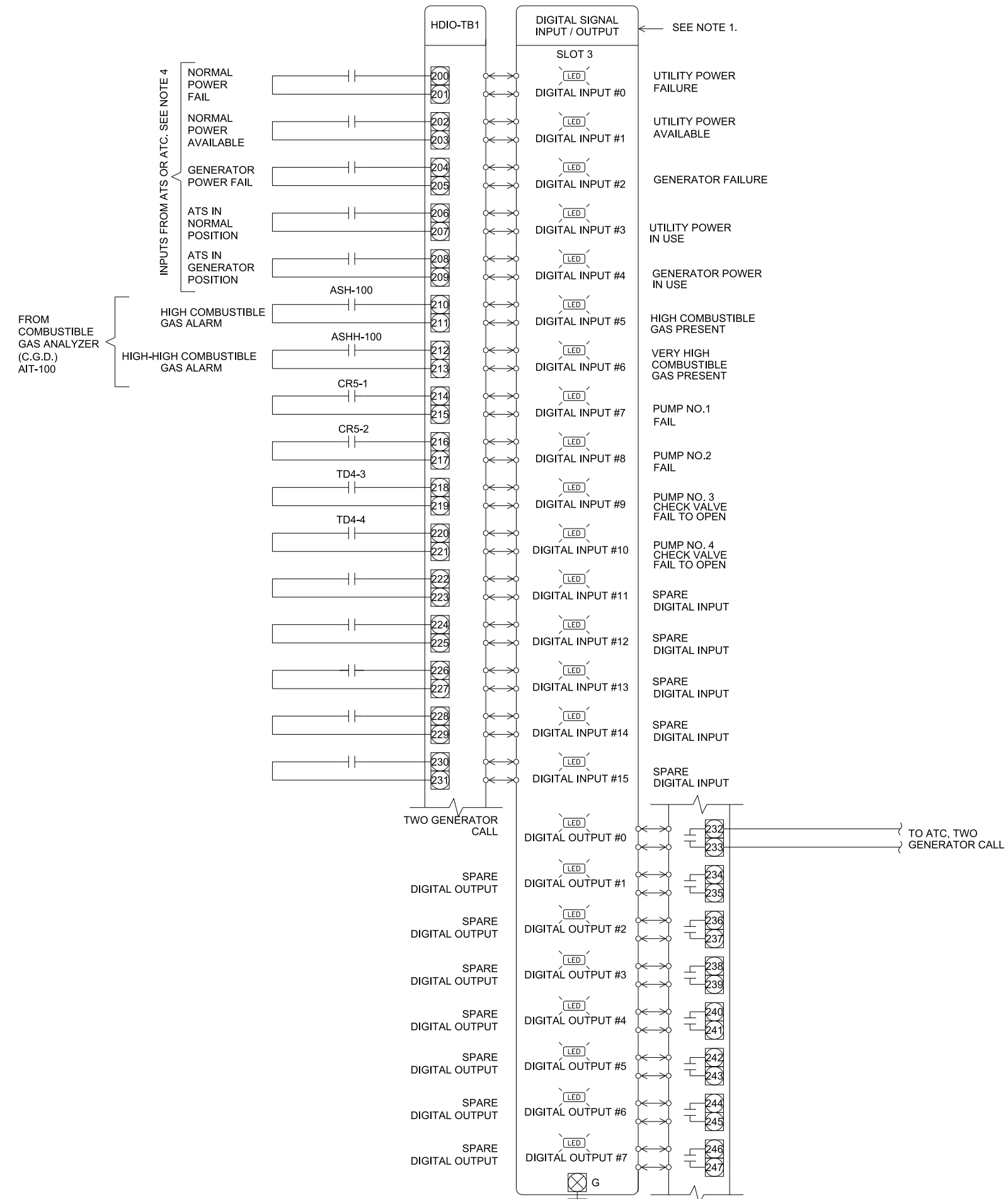

- NOTES:**
1. THE I/O AND ASSOCIATED DEVICES SHOWN ARE TYPICAL FOR PUMP NO. 1 THRU 4. PROVIDE ADDITIONAL I/O POINTS AND ASSOCIATED DEVICES FOR ADDITIONAL PUMPS UP TO A MAXIMUM OF EIGHT.
  2. MAKE SCALE ADJUSTMENTS BASED ON RESPECTIVE PARAMETERS OF THE PUMPS AND ASSOCIATED EQUIPMENT PROVIDED.
  3. ALL HARDWIRED I/O POINTS MUST HAVE TAG NUMBERS IN ACCORDANCE WITH PROGRAM TAG NUMBERING REQUIREMENTS.
  4. THIS DRAWING SHOWS THE I/O RELATED TO A SINGLE GENERATOR AND ATS INSTALLATION. SEE SHEET I-4A FOR I/O REQUIREMENTS FOR TWO GENERATORS AND AUTOMATIC TRANSFER SWITCH OR CONTROL SYSTEM. ADJUST I/O POINTS ACCORDINGLY.

**CH2MHILL**

CITY OF BATON ROUGE  
PARISH OF EAST BATON ROUGE  
DEPARTMENT OF PUBLIC WORKS  
BATON ROUGE, LOUISIANA

EXAMPLE  
PROGRAM PUMP STATION (PDP)  
[TYPE IIIA & IIIB]  
PLC I/O WIRING DIAGRAM SHT. 3

VERIFY SCALE	
BAR IS ONE INCH ON ORIGINAL DRAWING.	
DATE	MAY 2012
PROJ	350589
DWG	I-6
SHEET	

REUSE OF DOCUMENTS: THIS DOCUMENT, AND THE IDEAS AND DESIGNS INCORPORATED HEREIN, AS AN INSTRUMENT OF PROFESSIONAL SERVICE, IS THE PROPERTY OF CH2M HILL AND IS NOT TO BE USED, IN WHOLE OR IN PART, FOR ANY OTHER PROJECT WITHOUT THE WRITTEN AUTHORIZATION OF CH2M HILL. © CH2M HILL 2004. ALL RIGHTS RESERVED.

Tag Number (See Note 4)	Description	Read Bit	PLC ( * ) Address	Read Word	PLC ( * ) Address	Write Bit	PLC ( * ) Address	Write Word	PLC ( * ) Address
	Pump #1 VFD ON	1							
	Pump #1 VFD Fault	1							
	Pump #1 FAIL	1							
	Pump #1 MAS Unit Critical Fault	1							
	Pump #1 MAS Unit Warning	1							
	Low Level Wet Well A	1							
	High Level Wet Well A	1							
	Phase Failure	1							
	Pump E-Call Wet Well A	1							
	Bubbler Air Pressure Wet Well A	1							
	Pump #1 Check Valve Open (2SO)	1							
	Pump #1 Plug Valve Open (2SO)	1							
	Pump #1 Stator Temperature			1					
	Pump #1 VFD Speed Indication			1					
	Wet Well A Level (Bubbler)			1					
	Wet Well A Flow (Mag Meter)			1					
	Pump #1 VFD Current			1					
	Pump #1 VFD Speed Control							1	
	Pump #1 VFD Start Cmd (SCADA)					1			
	Pump #2 VFD ON	1							
	Pump #2 VFD Fault	1							
	Pump #2 FAIL	1							
	Pump #2 MAS Unit Critical Fault	1							
	Pump #2 MAS Unit Warning	1							
	Low Level Wet Well B	1							
	High Level Wet Well B	1							
	Phase Failure	1							
	Pump E-Call Wet Well B	1							
	Bubbler Air Pressure Wet Well B	1							
	Pump #2 Check Valve Open (2SO)	1							
	Pump #2 Plug Valve Open (2SO)	1							
	Pump #2 Stator Temperature			1					
	Pump #2 VFD Speed Indication			1					
	Wet Well B Level (Bubbler)			1					
	Wet Well B Flow (Mag Meter)			1					
	Pump #2 VFD Current			1					
	Pump #2 VFD Speed Control							1	
	Pump #2 VFD Start Cmd (SCADA)					1			
	Pump #3 VFD ON	1							
	Pump #3 VFD Fault	1							
	Pump #3 FAIL	1							
	Pump #3 MAS Unit Critical Fault	1							
	Pump #3 MAS Unit Warning	1							
	Phase Failure	1							
	Pump #3 Check Valve Open (2SO)	1							
	Pump #3 Plug Valve Open (2SO)	1							
	Pump #3 Stator Temperature			1					
	Pump #3 VFD Speed Indication			1					
	Pump #3 VFD Current			1					
	Pump #3 VFD Speed Control							1	
	Pump #3 VFD Start Cmd (SCADA)					1			
	Pump #4 VFD ON	1							
	Pump #4 VFD Fault	1							
	Pump #4 FAIL	1							
	Pump #4 MAS Unit Critical Fault	1							
	Pump #4 MAS Unit Warning	1							
	Phase Failure	1							
	Pump #4 Check Valve Open (2SO)	1							
	Pump #4 Plug Valve Open (2SO)	1							
	Pump #4 Stator Temperature			1					
	Pump #4 VFD Speed Indication			1					
	Pump #4 VFD Current			1					
	Pump #4 VFD Speed Control							1	
	Pump #4 VFD Start Cmd (SCADA)					1			
	Pump #5 VFD ON	1							
	Pump #5 VFD Fault	1							
	Pump #5 FAIL	1							
	Pump #5 MAS Unit Critical Fault	1							
	Pump #5 MAS Unit Warning	1							
	Phase Failure	1							
	Pump #5 Check Valve Open (2SO)	1							
	Pump #5 Plug Valve Open (2SO)	1							
	Pump #5 Stator Temperature			1					
	Pump #5 VFD Speed Indication			1					
	Pump #5 VFD Current			1					
	Pump #5 VFD Speed Control							1	
	Pump #5 VFD Start Cmd (SCADA)					1			

Tag Number (See Note 4)	Description	Read Bit	PLC ( * ) Address	Read Word	PLC ( * ) Address	Write Bit	PLC ( * ) Address	Write Word	PLC ( * ) Address
	Pump #6 VFD ON	1							
	Pump #6 VFD Fault	1							
	Pump #6 FAIL	1							
	Pump #6 MAS Unit Critical Fault	1							
	Pump #6 MAS Unit Warning	1							
	Phase Failure	1							
	Pump #6 Check Valve Open (2SO)	1							
	Pump #6 Plug Valve Open (2SO)	1							
	Pump #6 Stator Temperature			1					
	Pump #6 VFD Speed Indication			1					
	Pump #6 VFD Current			1					
	Pump #6 VFD Speed Control							1	
	Pump #6 VFD Start Cmd (SCADA)					1			
	Normal Power Failed	1							
	Normal Power Available	1							
	Generator ON	1							
	Generator Failed	1							
	Transfer Switch in Generator Position	1							
	Transfer Switch in Utility Position	1							
	AC Power Loss	1							
	Generator Low Fuel Level	1							
	Generator Battery Low Volts	1							
	Station Current Phase A			1					
	Station Voltage Phase A-B			1					
	Wet Well B Gas Detector			1					
	DC Power Fail	1							
	Pump Station Intrusion Alarm	1							
	Wet Well A Gas Detector			1					
	Pump Station Output Pressure			1					
	Vessel Level			1					
	Influent A Slide Gate Open	1							
	Wet Well Gate A to B OPEN	1							
	Influent B Slide Gate Open	1							
	Odor Panel Power Available	1							
	EQ Basin Pump #1 ON	1							
	EQ Basin Pump #1 Starter Fault	1							
	EQ Basin Pump #1 Check Valve Open	1							
	EQ Basin Pump #2 ON	1							
	EQ Basin Pump #2 Starter Fault	1							
	EQ Basin Pump #2 Check Valve Open	1							
	EQ Basin High High Level	1							
	EQ Basin Low Low Level	1							
	<b>TOTAL</b>	<b>79</b>		<b>28</b>		<b>6</b>		<b>6</b>	

- NOTES:
- USE THIS EXAMPLE AS A BASIS FOR DEVELOPMENT OF PROJECT SPECIFIC DATA EXCHANGE TABLE FOR SCADA. DESIGN ENGINEER TO INCLUDE THIS TABLE IN THE CONTRACT DOCUMENTS.
  - ( \* ) INDICATES BLANK COLUMNS TO BE FILLED IN BY CONTRACTOR / SYSTEMS INTEGRATOR.
  - CONTRACTOR IS RESPONSIBLE FOR DEVELOPMENT OF CUSTOMIZED DATA EXCHANGE TABLE FOR EACH PUMP STATION.
  - DESIGN ENGINEER TO DEVELOP TAG NUMBERS FOR ALL SIGNALS BASED ON PROGRAM TAG NUMBERING REQUIREMENTS.

**CH2MHILL**

EXAMPLE  
CITY OF BATON ROUGE  
PARISH OF EAST BATON ROUGE  
DEPARTMENT OF PUBLIC WORKS  
BATON ROUGE, LOUISIANA  
PROGRAM PUMP STATIONS (PDP)  
EXAMPLE OF DATA EXCHANGE TABLE  
FOR SCADA

VERIFY SCALE  
BAR IS ONE INCH ON ORIGINAL DRAWING.  
DATE MAY 2012  
PROJ 350589  
DWG I-7  
SHEET

REUSE OF DOCUMENTS: THIS DOCUMENT, AND THE IDEAS AND DESIGNS INCORPORATED HEREIN, AS AN INSTRUMENT OF PROFESSIONAL SERVICE, IS THE PROPERTY OF CH2M HILL AND IS NOT TO BE USED, IN WHOLE OR IN PART, FOR ANY OTHER PROJECT WITHOUT THE WRITTEN AUTHORIZATION OF CH2M HILL. © CH2M HILL 2004. ALL RIGHTS RESERVED.



Attachment E  
Owner Furnished Products Specification

---

**SECTION 01640**  
**OWNER-FURNISHED PRODUCTS**

**PART 1 GENERAL**

1.01 DEFINITIONS

- A. Supplier: The party under separate contract with Owner to furnish the products and special services specified herein, ARCCO Power Systems, 9918 South Perdue Ave., Baton Rouge, LA 70814.

1.02 OWNER-FURNISHED PRODUCTS

A. Engine-Generators:

1. Quantity: . Refer to pump station Drawings. Point of Transfer: Supplier's warehouse located in East Baton Rouge Parish at *at 9918 South Perdue Avenue* for generators 500 kW and smaller.
2. Larger generators will be delivered directly from the manufacturer to the pump station site and placed on the generator pad. If the generator pad is not ready to receive the generator, the generators shall be offloaded at the pump station site, and the Contractor shall be responsible for moving the generators to their pads when the pads are ready, including supply of the crane necessary to move the generator to the pads.
3. Estimated Date of Availability: Notify the Engineer and Owner 60 days in advance of required pick up and transfer based on meeting the construction schedule. Contractor may assume that generators will be available when required for installation.
4. Estimated weight of product: See Supplement at the end of this section.
5. Special handling and storage instructions: In accordance with the generator Supplier's instructions.
6. Associated special services to be provided by Supplier:
  - a. Certification of proper installation.
  - b. Functional Testing: Supplier will take the lead in performing functional testing.
  - c. Performance Testing: Supplier will take the lead in performing performance testing.

1.03 INFORMATION FURNISHED BY OWNER

- A. Shop drawings related to Owner-furnished products: See Supplement at the end of this section..
- B. Manufacturer's installation, operation, and maintenance instructions for Owner-furnished products: See Supplement at the end of this section..

## 1.04 SUBMITTALS

## A. Action Submittals:

1. Shop Drawings: Submit 45 calendar days prior to generator equipment pickup date
  - a. Show layout, location, and identification of materials provided by Contractor for installation of Owner-furnished products.
  - b. Provide electrical and instrumentation diagrams to indicate connecting and interconnecting electrical and control work.

## 1.05 TRANSFER OF PRODUCTS

- A. Items will be stored at the Supplier's warehouse until Contractor is ready for pick up.
- B. Prior to loading, conduct with Owner, Engineer and Supplier a joint inspection for the purpose of identifying product, general verification of quantities, and observation of apparent condition.
- C. Do not load damaged or incomplete products.
- D. Indicate signed acceptance of delivery on the transfer form provided by the Engineer.
- E. Following transfer, provide insurance for the Owner-furnished products up to the time of Final Acceptance by the Owner. Estimated values of the Owner-Furnished products are included in the Supplement to this section.

## 1.06 LOADING, TRANSPORTING, UNLOADING, STORAGE, AND MAINTENANCE

- A. Supplier will have hoisting equipment available at Supplier's warehouse to load generators.
- B. Contractor shall secure equipment on the truck and transport to the appropriate site(s).
- C. Subsequent to transfer, Contractor shall have complete responsibility for unloading Owner-furnished products at the pump station sites. Unload product in accordance with manufacturers' instructions.
- D. Store, protect, and maintain product to prevent damage until final acceptance of completed work. Damage to or loss of products after date of transfer to Contractor shall be repaired to original condition, or replaced with new identical products, at the discretion of Engineer.
- E. Maintain inventory of Owner-furnished products after transferred to Contractor.

## 1.07 SCHEDULING

- A. Owner will keep Contractor informed of probable delivery dates to the Supplier's warehouse.
- B. Owner will confirm transfer date with Contractor 10 days prior to scheduled transfer.
- C. Provide a minimum of 10 days notice to Owner that Owner-furnished product is ready for all startup services listed herein to be furnished by Owner through its contract with Supplier.

## 1.08 EXTRA MATERIALS

- A. Unless otherwise specified, Owner will take acceptance of, and be responsible for storing associated extra materials and special tools upon delivery.

## **PART 2 PRODUCTS (NOT USED)**

## **PART 3 EXECUTION**

### 3.01 WORK SEQUENCING RESTRAINTS

- A. Prior to picking up and transporting the Owner-Furnished engine-generator to a particular site, the Contractor shall have completed certain elements of the work at that particular site. The purpose of this sequencing restraint is to minimize the time a generator sits at a pump station site prior to its startup. The elements of the Work to be completed are listed below. This sequencing restraint will require that the automatic transfer switch for a particular site will need to be obtained from the Supplier's warehouse prior to the engine-generator, and the Contractor shall factor this into the sequencing of the Work.
  1. Raise the Site grade, if required at a particular site, and complete other required earthwork and paving, walk, or drive repair.
  2. Pour and cure the concrete foundation for the engine-generator, or construct the steel platform for the generator, if that is required for a particular site. Handrails, if required for a foundation, may be installed after the generator is installed.
  3. Install or modify the fence at the Site, including gate installation. If required for access, a portion of the fence may be left down, but the fence shall be installed, at least temporarily, by the end of the day on which the generator is placed on the foundation.
  4. Complete the modifications to the electrical service, as shown on the General Electrical Installation detail for the particular site, including installation of the automatic transfer, and restore the normal power service to the power station through the modified electrical service.
  5. Install the required conduit runs from the electrical service and automatic transfer switch to the generator location. Stub up and

temporarily cap prior to setting the generator. Connection of conduits to the generator and pulling of conductors to and termination of conductors at the generator shall be completed after the generator is set on its foundation.

### 3.02 INSTALLATION

- A. Install products in conformance with Owner-furnished product shop drawings and installation instructions provided as a Supplement at the end of this section.
- B. Provide interconnecting structures, equipment, piping, electrical and instrumentation work, finish painting, and appurtenances to achieve a complete and functional system.
- C. Provide foundation pads for Owner-furnished products as shown on the Drawings. Verify dimensions and configuration of pads, including penetrations, with Owner-furnished product Shop Drawings.
- D. Anchor Bolts:
  - 1. Where required, provide anchor bolts, fasteners, washers, and templates required for installation of Owner-furnished products.
  - 2. Size and locate anchor bolts in accordance with Owner-furnished product Shop Drawings and installation instructions provided as a Supplement at the end of this section.
- E. Mechanical and electrical equipment shall be properly aligned, plumb and level, with no stresses on connecting piping or conduit.
- F. Install vibration insulators when finished with Owner-Furnished products.
- G. Verify operability and safety of electrical system needed to operate equipment. Check electrical system for continuity, phasing, grounding, and proper functions.

### 3.03 FIELD FINISHING

- A. Products will be delivered with prime and finish coat(s) applied.
  - 1. Touchup or repair damage to coatings resulting from unloading, storage, installation, testing, and startup.
  - 2. If finish coats are damaged extensively after transfer, completely repaint.
  - 3. Touchup, repair, or complete repainting shall match color of original paint, and shall be fully compatible with applied primers and finish.

### 3.04 PRODUCT PROTECTION

- A. Immediately after installation, lubricate components in accordance with manufacturer's instructions.
- B. Follow manufacturer's instructions for protection and maintenance during storage, after installation, during testing and startup, and after startup but prior to acceptance.
- C. Furnish incidental supplies including lubricants, cleaning fluids, and similar products as needed for protecting and maintaining the Owner-furnished products.
- D. Supplier will furnish diesel fuel for generator during startup. Contractor shall furnish diesel fuel needed to run unit during onsite storage prior to startup.

### 3.05 TESTS AND INSPECTION

- A. Tests and inspections of installed products shall be in accordance with requirements shown below.
  - 1. Supplier will inspect installation and issue a Certificate of Proper Installation prior to testing. Contractor shall remedy deficiencies noted by Supplier associated with the work performed by the Contractor.
  - 2. Functional Test: Assist Supplier in performing functional test to verify generator runs within its allowable limits, that unit's safety devices function, and that automatic transfer switch transfers the load to the generator on loss of utility power and back on restoration of power.
  - 3. Performance Test: Assist Supplier in performing load cell test to verify rated output of generator and test to verify generator can power the installed load. Supplier will supply and temporarily wire the load cell.
  - 4. Contractor to provide assistance during testing to correct installation issues relating to the Contractor scope of Work. As a minimum, the Contractor's electrician shall be present during the Functional Test and for the Performance Test until the generator is operating in a steady state.

### 3.06 SUPPLEMENTS

- A. The supplement listed below, following "END OF SECTION," is part of this Specification.
  - 1. Shop Drawings and Operation and Maintenance instructions for the Owner-furnished products.
  - 2. Estimated Equipment Value, Weight, and Size.

**END OF SECTION**

**Attachment F**  
**Electrical Load Estimate Sheet**

---

## Baton Rouge Sanitary Sewer Overflow Project Pump Station Electrical Load Estimate Sheet

<b>Project Name</b>	
<b>Pump Station No.</b>	
<b>Design Phase</b>	
<b>Lead Engineer</b>	
<b>Electrical Engineer</b>	

<b>Pumps</b>				<b>Starting Method</b>
<b>(Provide Data for No. Used)</b>	<b>Motor HP</b>	<b>Voltage (kW)</b>	<b>Phases</b>	
1				
2				
3				
4				
5				
6				
7				
8				

ATL = Across the line  
 SS = Soft start  
 AFD = Adj Freq Drive  
 AT = Auto Transformer

**Auxiliary Loads - Fill In Those That Apply and Add Others In Spaces Provided**

**Do Not Itemize Loads Fed by the 115/230 V. Transformer**

115/230 V. Transformer		kVA			
Sump Pump 1		HP		Volts	Phase
Sump Pump 2		HP		Volts	Phase
Odor Control Fan 1		HP		Volts	Phase
Odor Control Fan 2		HP		Volts	Phase
Exhaust Fan 1		HP		Volts	Phase
Exhaust Fan 2		HP		Volts	Phase
Air Conditioner 1		FLA		Volts	Phase
Air Conditioner 2		FLA		Volts	Phase
Air Conditioner 3		FLA		Volts	Phase
		HP/FLA		Volts	Phase
		HP/FLA		Volts	Phase
		HP/FLA		Volts	Phase
Generator Jacket Water Heater		kW	To be filled out by Program Management Team		
Calculated Generator Size		kW	To be filled out by Program Management Team		



Attachment G  
Automatic Transfer Control System Specification

**SECTION 26 36 24**  
**AUTOMATIC TRANSFER CONTROL SYSTEM**

**PART 1        GENERAL**

1.01        REFERENCES

- A.        The following is a list of standards that may be referenced in this section:
1.        Institute of Electrical and Electronics Engineers (IEEE):
    - a.        C37.90.1, Standard for Surge Withstand Capability (SWC) Tests for Relays and Relay Systems Associated with Electric Power Apparatus.
    - b.        C37.90.2, Standard for Withstand Capability of Relay Systems to radiated Electromagnetic Interference from Transceivers.
  2.        National Electrical Manufacturers Association (NEMA):
    - a.        ICS 1, General Standards for Industrial Control and Systems: General Requirements.
    - b.        ICS 2, Industrial Control and Systems Controllers, Contactors, and Overload Relays not more than 2000 volts ac or 750 volts ac.
    - c.        ICS 6, Industrial Control and Systems: Enclosures 250, Enclosures for Electrical Equipment (1,000 Volts Maximum).
  3.        National Fire Protection Association (NFPA): 70, National Electrical Code (NEC).
  4.        Underwriters Laboratories, Inc. (UL): 1008, Transfer Switch Equipment.

1.02        SUBMITTALS

- A.        Action Submittals:
1.        Descriptive product information.
  2.        Dimensional drawings.
  3.        Control diagrams.
  4.        Interface drawings with existing switchgear.
  5.        Equipment ratings.
- B.        Informational Submittals:
1.        Factory test reports.
  2.        Operation and Maintenance Data: Complete operations and maintenance information for components provided.
  3.        Manufacturer's Certificate of Proper Installation.

1.03        QUALITY ASSURANCE

- A.        Authority Having Jurisdiction (AHJ):
1.        Provide the Work in accordance with NFPA 70, National Electrical Code (NEC). Where required by the AHJ, material and equipment shall be labeled or listed by a nationally recognized testing laboratory or other organization acceptable to the AHJ in order to provide a basis for approval under NEC.
  2.        Materials and equipment manufactured within the scope of standards published

by Underwriters Laboratories, Inc. shall conform to those standards and shall have an applied UL listing mark.

## **PART 2 PRODUCTS**

### **2.01 MANUFACTURERS**

- A. Materials, equipment, and accessories specified in this section shall be products of:
  - 1. G&W Electric Company Model ATC 451.
  - 2. GE Model MX250.

### **2.02 GENERAL**

- A. Provide a microprocessor based automatic transfer control system to monitor utility power, systematically monitor and control switchgear main and tie breakers, and provide load based control of standby generators to ensure electric power to the switchgear according to the requirements specified. The automatic transfer control system shall be the standard product of the manufacturer.
- B. The automatic transfer control system shall interface with power operated breakers provided as part of the facility's main switchgear specified under a separate specification section. Provide all needed components to interface the automatic transfer control system with breakers for OPEN and CLOSE control and respective position monitoring.
- C. In accordance with applicable standards of NFPA 70, NEMA ICS 1, NEMA ICS 2, NEMA ICS 6, IEEE C37.90.1, IEEE C37.90.2, and UL 1008.
- D. Operating Conditions:
  - 1. Ambient Temperature: Maximum 50 degrees C.
  - 2. Equipment to be fully rated without any derating for specified operating conditions.

### **2.03 ENCLOSURE**

- A. Type: Nonventilated NEMA 250, Type 12 when mounted in dedicated enclosure.
- B. Dead front, front accessible wall mounted cabinet with 14-gauge welded stainless steel construction.
- C. Continuously hinged single door, with handle and lock cylinder.
- D. Finish: Baked enamel applied over rust-inhibiting, phosphated base coating.
  - 1. Interior Panel Components' Color: Provide gray finish as approved by Owner.
  - 2. Unpainted Metal Parts: Plated for corrosion resistance.
- E. Optional Enclosure Type: Open for mounting in transfer control cubical in switchgear. Contractor has option to install automatic transfer control system in switchgear line-up.

## 2.04 CONTROL MODULE

- A. Completely enclosed and mounted separately from switchgear.
- B. Microprocessor for sensing and logic control with inherent digital communications capability.
- C. Plug-in, industrial grade interfacing relays with dust covers.
- D. Connected to switchgear main breakers and tie-breaker by wiring harness having keyed disconnect plug.
- E. Plug-in printed circuit boards for sensing and control logic.
- F. Adjustable solid state undervoltage sensors for all three phases of normal and for one phase of standby generator source:
  - 1. Pickup: 85 to 100 percent nominal.
  - 2. Dropout: 75 to 98 percent of pickup setting.
- G. Adjustable frequency sensors for standby generator source:
  - 1. Pickup: 90 to 100 percent nominal.
  - 2. Dropout: 87 to 89 percent of pickup setting.
- H. Control module with adjustable time delays:
  - 1. 0.5 to 6-second engine start delay.
  - 2. 0 to 5-minute load transfer to standby generator delay.
  - 3. 0 to 30-minute retransfer to normal delay.
  - 4. 0 to 30-minute unload running time delay.
  - 5. Switch to bypass above time delays during testing.
- I. Form-C start contacts, rated 10 amperes, 32-volt dc, for two-wire engine control, wired to terminal block.
- J. Exerciser, adjustable in 15-minute increments, 7-day dial clock to automatically exercise generator complete with door mounted NO LOAD and LOAD selector switch.
- K. Adjustable 0 to 5 minutes time delay relay for engine starting signal.

## 2.05 INDICATORS

- A. Type: Manufacturer's standard.
- B. Green lens to indicate switchgear position for normal power source.
- C. Red lens to indicate switch position for standby generator power source.
- D. White lens to indicate normal power source is available within parameters established by pickup and dropout settings.

- E. Amber lens to indicate standby generator power source is available within parameters established by pickup and dropout settings.
- F. Provide one normally open and one normally closed, 5 amperes, 120-volt contact for remote indication when automatic transfer control system is in either position.

2.06 GENERATOR PARALLELING EQUIPMENT

- A. When multiple generators are required at a given Site, provide the following components for each Owner-provided generator that will allow multiple generators to be paralleled to a common bus:
  - 1. Baldor, IntelliGen Controller.
  - 2. Baldor, Generator Paralleling Dongle.
  - 3. Baldor, IG Transformer.
  - 4. Baldor, IG AVR1.
  - 5. Baldor, Motorized Circuit Breaker.

2.07 LOAD BASED GENERATOR CONTROLS

- A. Where multiple generators are utilized at a given facility, provide generator and load controls to optimize generator operating capacity with pump demand. Load based generator controls (LBGC) shall monitor the number of pumps that level control system is requesting and initiate the appropriate number of generators prior to starting the individual pumps. LBGC shall be provided with the following functionality:
  - 1. When Utility power is initially lost and ATC calls for generator operation, the LBGC shall call for all generators to start, reach rated voltage and frequency and allow each generator’s controller parallel to the generator side of the main switchgear. The LBGC shall then allow the ATC to close the generator main breaker in the main switchgear.
  - 2. Once initial load at pump station has stabilized for a period of 5 minutes, the LBGC shall initiate the shutdown of excess generators. The number of generators operating shall correlate with the numbered pumps in operation in the following table:

<b>Table 1</b>					
<b>Number of Generators</b>	<b>1<sup>st</sup> Pump Combination</b>	<b>2<sup>nd</sup> Pump Combination</b>	<b>3<sup>rd</sup> Pump Combination</b>	<b>4<sup>th</sup> Pump Combination</b>	<b>5<sup>th</sup> Pump Combination</b>
1					
2					
3					
4					
5					

- 3. When pump station level controls requests an additional pump to start, the LBGC shall verify that the appropriate generator capacity is

- operating and if needed start additional generators. The LBGC shall acknowledge appropriate generating capacity via a discrete signal to the pump station level controls to allow the additional pump to start.
4. When pump station level controls stops a pump, the LBGC shall initiate the shutdown of excess generators to match Table 1 above.

B. The LBGC shall incorporate the following I/O points:

1. Discrete Inputs:
  - a. Pump ON: Command from pump station level controls for each pump.
  - b. Generator RUNNING: Status from each generator.
  - c. Standby source ON: Command from ATC.
  - d. Wet well HIGH-HIGH level alarm.
2. Discrete Outputs:
  - a. Generator RUN: Command for each generator.
  - b. Pump RUN: Permissive for each pump.
  - c. LBGC common FAIL to SCADA system.

## 2.08 FACTORY TESTS

A. Test to ensure correct:

1. Operation of individual components.
2. Sequence of operation.
3. Transfer time, voltage, frequency, and time delay settings.

## PART 3 EXECUTION

### 3.01 INSTALLATION

- A. Install in accordance with manufacturer's instructions.
- B. Secure enclosure to structural steel channels attached to wall surface.

### 3.02 FIELD QUALITY CONTROL

A. Functional Test:

1. Conduct on each controller.
2. Inspect ATCS for electrical supply termination connections, interconnections, proper installation, and operation.
3. Test for system operation with main-tie-main breakers and generator(s) in every possible scenario of breaker position, generator and utility source availability and operation all duty pumps, if LBGC is provided, to assure that they system will not encounter a situational malfunction.
4. Record test data for report.

B. Performance Test:

1. Conduct on entire installed system, including main switchgear, engine generators and pumps.

2. Perform under actual or approved simulated operating conditions.
3. Demonstrate proper transfer of load from Utility source to engine generator source with the simulation of Utility power loss, including all associated sequence timers.
4. Demonstrate proper transfer of load back from engine generator source to Utility source, including all associated sequence and cool-down timers.
5. Demonstrate performance of the LBGC by manually operating combinations of pumps, as input conditions and wet well level allows, to verify the appropriate number of generators operate.
6. Record test data for report.

3.03 MANUFACTURERS' SERVICES

- A. Manufacturer's Representative: Present at Site or classroom designated by Owner, for minimum person-days listed below, travel time excluded:
  1. 2 person-days for installation assistance and inspection.
  2. 3 person-days for functional and performance testing and completion of Manufacturer's Certificate of Proper Installation.
  3. 1 person-days for functional demonstration to be witnessed by Owner and Site training of proper operation.

**END OF SECTION**

**Attachment H**  
**Pump Station Equipment Commissioning Specification and**  
**Checklist**

---



# EQUIPMENT COMMISSIONING FOR PROGRAM PUMP STATIONS

\*\*\*\*\*

Revision No.: 1

Revision Date: 20 February, 2012

Specification Owner: Larry Fettkether/CH2M HILL

\*\*\*\*\*

\*\*\*\*\*

Note To Specifier (NTS): This specification requires editing based on the size and configuration of the pump station to be commissioned, the extent to which the electrical system has been modified during pump station construction, whether ancillary facilities such as an odor control system or a generator are present, and whether the pump station needs to be tested off line before connecting to the sewer system. It also needs to be coordinated with other technical specifications which may have also have commissioning or start up sections so as not to duplicate or provide conflicting requirements.

\*\*\*\*\*

## PART 1 GENERAL

### 1.1 SCOPE

- A. This Specification includes the development of a plan for and the performance of the pump station equipment commissioning. The focus is on the commissioning of the operating equipment, electrical system and control system, and verifying the pump station operates as designed.
- B. Testing requirements for materials, such as pipe pressure testing, concrete testing, and compaction testing, are covered in other sections of these Contract Documents and are generally prerequisites to the pump station commissioning. Coordinate the Work of this section with testing requirements contained in the equipment and material Specifications.

### 1.2 SUBMITTALS

- A. Submit the following items:
  - 1. Pump Station Commissioning Plan.
  - 2. Test instrument calibration certificates.

\*\*\*\*\*

NTS: Delete this submittal if there is no odor control system on Project.

\*\*\*\*\*

- 3. Odor Control Duct System Air Balance Report.
    - 4. Test Results: Functional and performance for pumps, electrical gear, and control system.

5. Manufacturer's Certificates of Proper Installation for raw sewage pumps, sump pumps, electrical switchgear, starters, MCCs, VFDs, automatic transfer switches, generators, control panels, field instruments, odor control systems, HVAC systems, slide and sluice gates, valves, hoists, and other equipment as applicable. These certificates may be required and submitted under the individual equipment specifications, but copies should be collected and included in the commissioning plan.
6. Copies of factory calibration certificates for instruments such as flow meters, pressure transmitters, gas detectors, pressure switches and other field-mounted devices. Lacking a factory calibration certificate, provide a certificate of field calibration of these instruments. These certificates may be required and submitted under the individual equipment specifications, but copies should be collected and included in the commissioning plan.
7. Copies of manufacturer's field personnel start up logs for equipment for which these are provided.
8. HVAC system air balance and system start up reports where the project includes a building .
9. SCADA system register exchange table for the PLC.
10. Completed commissioning check list.

### 1.3 COMMISSIONING COORDINATOR

- A. Designate a person to be commissioning coordinator; responsible for:
  1. Planning and coordinating commissioning process.
  2. Arranging visits by manufacturer's representatives.
  3. Coordinating with Owner and Engineer during commissioning process.

### 1.4 COMMISSIONING PLANNING MEETINGS

- A. Initial Meeting: Conduct when construction is approximately 80 percent complete, or earlier if necessary to arrange required manufacturers' site visits.
- B. Follow-on Meetings: Conduct as necessary to finalize or update Commissioning Plan or address issues that arise during commissioning process.
- C. Attendees: Owner, Engineer, Contractor's commissioning coordinator, appropriate Contractor and Subcontractor staff, and appropriate manufacturers' representatives.

### 1.5 COMMISSIONING PLAN

- A. Develop a written Commissioning Plan that addresses the following issues at a minimum. First draft shall be available for review at the Initial Commissioning Meeting.
  1. Schedule.
  2. Completion of commissioning prerequisites.
  3. Status of required utilities for startup, such as water, power, chemicals, and sewer connection.
  4. Detailed procedure for startup.
  5. Temporary arrangements required for commissioning, such as bypass piping, generators, additional valves, control system override, test instruments, or removal of system valves to allow testing of pump station under the expected start up conditions, which may

- include not having pump station inlet or discharge piping connected, or not having sufficient flow available to operate the pump station under design conditions..
- 6. Contractor, Subcontractor and Manufacturers’ personnel required for commissioning.
- 7. Involvement of Owner’s operating personnel in commissioning process.

1.6 PREREQUISITES

- A. The following activities, as applicable to Project, should be completed prior to start of onsite pump station commissioning activities:
  - 1. Commissioning Planning Meeting(s).
  - 2. Approved Commissioning Plan.
  - 3. Test instrument certification.
  - 4. Compaction testing.
  - 5. Concrete slump and cylinder testing.
  - 6. Pipe pressure testing.
  - 7. Wet well leak testing.
  - 8. Slide/slucice gate leak testing.
  - 9. Verification that equipment is installed and ready for operation, including receipt of Manufacturer’s Certificates of Proper Installation for equipment where required in the individual equipment Specifications.
  - 10. Coordination with public utilities to obtain service for power and water.
  - 11. Coordination with permit issuers and inspectors to obtain required permission to operate system for testing.
  - 12. Programming of and initial setpoint adjustment of PLC and instruments.
  - 13. Startup of building or control panel air conditioning and ventilation systems.
  - 14. Building lights operational.
  - 15. Instrument calibration.

\*\*\*\*\*

NTS: Delete this requirement if there is no odor control system on Project.

\*\*\*\*\*

- 16. Verify odor control system media and chemicals are on hand.

1.7 SEQUENCING

- A. In addition to prerequisites listed above, be aware that certain steps in the commissioning process need to occur before others; factor into commissioning schedule.

\*\*\*\*\*

NTS: Delete this choice if there is no odor control system on Project.

\*\*\*\*\*

- 1. As an example, electrical system commissioning needs to precede commissioning of pumps and pump control system [, and odor control system,] as these need power to perform motor rotation checks, and functional and performance testing.
- B. Commissioning schedule shall reflect required sequences in commissioning of various parts of pump station and allow for commissioning to occur over multiple days in an appropriate order.

## PART 2 PRODUCTS (Not Used)

## PART 3 EXECUTION

### 3.1 TEST EQUIPMENT

- A. Provide required test instrumentation for commissioning process.
  - 1. Where installed instrumentation exists, propose its use in Initial Commissioning Planning Meeting; subject to approval by Owner or Engineer.
  - 2. Instrument Calibration:
    - a. Submit proof of calibration.
    - b. Test instruments shall have been calibrated within 1 year prior to test date.

### 3.2 COMPONENT AND SYSTEMS TESTING

- A. Gates and Valves:
  - 1. Manually open and close hand-operated gates and valves.
  - 2. Electrically open and close actuated gates and valves using pushbuttons on actuator or remote pushbutton station (or both, if both are furnished).
  - 3. Verify gate position lights activate and gate position is indicated at control system, if specified.
  - 4. Demonstrate manual back up operation for actuators furnished with handwheel or other manual override device.
  - 5. Test backflow preventer using a certified backflow testing agency to demonstrate proper function of the valve.
- B. Sump Pumps:
  - 1. Demonstrate ability of sump pumps to dewater basins or vaults in which they are located.
  - 2. If pumps have automatic level controls, use controls during dewatering demonstration.
  - 3. Measure volume of water in basin or vault using basin's or vaults dimensions.
  - 4. Record time required to pump water out in order to estimate pump flow rate.
  - 5. Compare pumped flow rate to sump pump's design flow rate.
  - 6. Resolve discrepancies of more than 20 percent.
- C. Wastewater Pump
  - 1. Functional Test: Purpose of pump functional test is to demonstrate pumps slide on their rails, seat on their discharge elbows, operate without excessive noise or vibration, draw expected electrical current, and develop design head.
    - a. Pump Removal and Installation:
      - 1) Hoisting equipment shall be available during commissioning to lift pumps from wetwell and reinstall in wetwell.
      - 2) Demonstrate pumps slide freely without binding on rail system and seat on base elbow.
    - b. Pump Rotation Check: Bump pumps to verify proper rotation direction of each pump impeller.
    - c. Pumping Arrangement Options:
      - 1) Depending on situation with pump station being commissioned, functional test may be performed using clean water in a recirculation mode, or actual

- wastewater received from collection system and pumped to system discharge line.
- 2) In most situations it is recommended that performance test be conducted with clean water and pumps operating in a recirculation mode. Pumping mode to be used for functional test shall be discussed and agreed upon at Initial Commissioning Planning Meeting.
- d. Recirculation Mode:
- 1) Use for pump stations that must be connected into system in a manner that is nonreversible or if pump station influent or discharge lines are not yet ready for service.
    - a) If existing gravity lines must be directed to new pump station wetwell by breaking out pipes or cutting in new fittings, and once these steps are taken flow cannot be easily redirected to existing pump station which is still operable, then new pump station must be functionally tested in recirculation mode.
    - b) This will allow verification that new pump station is operable before pipe cutovers are made.
  - 2) In recirculation mode, fill pump wetwell with water to appropriate level, and run pumps one or more at a time with pump discharge recirculated back to wetwell.
    - a) One option for routing pump discharge back to wetwell is to route a temporary pipe out valve vault hatch and back into a new manhole upstream of wetwell, if part of Project, or through wetwell hatch.
      - (1) If run back into wetwell via wetwell hatch, arrange piping configuration to prevent splashing, turbulence, and air entrainment in wetwell.
      - (2) Recirculation line should have a plug valve and a pressure gauge in it to allow throttling pump discharge to attain design pump discharge head.
    - b) Second option to recirculate flow is to remove check valve from one of the pump discharge lines, remove that pump, and recirculate flow backward through line into wetwell via base discharge elbow.
      - (1) Perform on second pump as well, to allow testing of pump that was initially removed.
  - 3) Use clean water for recirculation test.
    - a) Fill wetwell from city water line typically present at each pump station, or by arrangement with Baton Rouge Water to fill from a fire hydrant using an appropriate backflow device.
    - b) If no clean water is available, use of sewage may be discussed at Initial Commissioning Planning Meeting.
  - 4) Test Procedures:
    - a) When temporary piping arrangements are complete and wetwell filled, run each pump in manual for a minimum of 1 hour.
    - b) Throttle valve in recirculation line to achieve pump's design discharge pressure; account for vertical distance from wetwell water surface to gauge elevation.
    - c) While operating each pump, record voltage and amps in each leg of power supply.

- d) Visually check for vortex formation or other flow pattern irregularities in wetwell or indications that pump flange is not sealed properly at its connection to base elbow.
  - e) Perform visual and audible check for pump cavitation or excessive vibration.
  - f) For pumps operating on VFDs:
    - (1) Ramp pump up to about 50 percent speed initially and check pump for proper operation in regard to vortex formation, cavitation, flange sealing, vibration and noise.
    - (2) Increase speed in 10 percent increments, checking for proper operation at each speed until pump is operating at 100 percent speed.
    - (3) Take voltage and amp readings on VFD inlet side and amp readings on motor side at 100 percent speed.
2. Performance Test:
- a. General:
    - 1) Conduct with Owner and Engineer present.
    - 2) Perform testing after new influent and discharge lines have been connected to pump station and pumps are pumping system wastewater.
    - 3) Goal of performance testing is to demonstrate operation of pumps controlled by pump station level instrumentation and PLC, and pump station high and low level alarms and PLC failure operation mode.
    - 4) Wastewater availability may make it difficult to demonstrate full operation of pump station, particularly for those stations with high wet weather flows, or those with separate wet weather pump stations.
      - a) In such cases devise testing plan, with Owner's and Engineer's input, that demonstrates operation of all pumps, even if all pumps cannot be run simultaneously to demonstrate peak pump station capacity.
      - b) In such cases, testing plan shall consider letting wetwell fill with all pumps off as a way to demonstrate operation at high wetwell levels (simulated high system flow rates), or using an upper speed limit on pump VFDs to artificially limit pump capacity and force more pumps to run, demonstrating proper pump start sequence occurs.
    - 5) Conduct for 4 hours minimum for duplex and triplex pump stations, and 8 hours minimum for larger pump stations.
    - 6) Dry weather and wet weather pump stations shall be considered as two separate stations and require a minimum of 8 hours each for demonstration.
  - b. Wetwell Level Control:
    - 1) Pump testing shall demonstrate that as pump wetwell level rises and falls, pumps start and stop in sequence as programmed, and that pump speeds ramp up and down to maintain wetwell level setpoints. Manipulate pump capacities and levels as required to demonstrate operation over full range of wetwell levels and operation of pumps.
    - 2) While operating under normal wetwell level control, observe wetwell for evidence of vortex formation or other wetwell flow irregularities and ability of pumps to remove floating scum and grease from wetwell. Monitor pumps by visual and audible means for excessive noise or vibration.
    - 3) While operating under normal wetwell level control, record wetwell level, pump discharge pressure, pump voltage and amperage for each phase, and pump station flow.

- a) For pump stations with flowmeters, measure flow using installed meter.
  - b) For pump stations without flow meters, pumping capacity shall be determined by using wetwell volumes and time required to pump a given volume, accounting for both influent and discharge of pump station.
  - c) Compare measured flows to design capacity of pumps.
  - d) Discrepancies in flows of more than 10 percent shall be investigated and resolved.
- c. Wetwell High and Low Level Alarm and Control:
- 1) Normal wetwell level control functions shall be overridden to force both wetwell high level and low level conditions. Demonstrate proper operation of high and low level alarms and pump override controls.
  - 2) At low level condition, wet well shall be observed for evidence of vortex formation or other wetwell flow irregularities. Monitor pumps by visual and audible means for excessive noise or vibration.
- d. Control Panel PLC Failure Simulation:
- 1) Turn off PLC power to demonstrate a PLC failure and functioning of high and low level control elements to operate pumps.
  - 2) Demonstrate operation of appropriate alarms.
- e. Modify Control Set Points As Required:
- 1) At the completion of performance testing, coordinate with the City operations staff and adjust wetwell level control settings or pump speed control settings to suit the conditions found in the field.
- f. After performing the 8-hour witnessed performance tests, the pumps shall operate in automatic control for a 72-hour continuous period prior to acceptance by the City. During this period the pump station shall be put in automatic mode and allowed to operate.
- 1) This test shall start at the beginning of a normal working day and the pump station shall be attended by an employee of the Contractor for the first 8 hours of operation. If the station operates successfully for 8 hours it may be run unattended through the following night. Over the next 2 days, the pump station shall be monitored at least once every 2 hours by the Contractor during normal working hours. If it operates successfully during these hours it may again be operated unattended during the night.
  - 2) During normal working hours, the Contractor shall record which pumps are operating, pump elapsed operating time, pump amperage, pump percent operating speed, wet well level, and any stored alarms hourly on day one and every 2 hours on days 2 and 3.
  - 3) If the 72-hour test is interrupted by a pump station failure, the test shall be restarted and repeated until the pump station operates for 72 continuous hours. The Owner or Engineer may allow the test to be resumed without restarting the test if the failure is a minor issue that is easily corrected or that does not affect the entire pump station.

\*\*\*\*\*

NTS: The following is based on engine-generator being Owner-furnished equipment. Modify if engine-generator is furnished as part of the pump station project.

\*\*\*\*\*

D. Engine Generator System:

1. Verify power and control conductors are terminated correctly and generator is grounded according to Contract Documents.
2. Neutral Bonding Jumper:
  - a. When three-pole transfer switch is installed, confirm jumper is removed where neutral is not switched.
  - b. When four-pole transfer switch is installed as a separately derived source ensure jumper is correctly installed.
3. Support City of Baton Rouge's generator startup activities as it relates to Contractor's installation and associated connections.
4. Provide support for the generator performance testing with a load cell or actual installed loads.

\*\*\*\*\*

NTS: Modify the following list of commissioning activities based on how much of the electrical system has been modified or replaced for the current project.

\*\*\*\*\*

E. Electrical, Instrument, and Controls System:

1. General:
  - a. Perform inspection and testing in accordance with NETA ATS, industry standards, and manufacturer's recommendations.
  - b. Tests and inspections shall establish installation operates properly and conforms to requirements of Contract Documents, NFPA 70, NFPA 70E, NFPA 101, and IEEE C2.
2. Raceways: Verify the following:
  - a. Exposed conduits are supported appropriately with fittings and support devices wrench tight.
  - b. Materials are appropriate for area classification.
  - c. Conduit sealing fittings installed correctly.
  - d. Sealing fitting compound has been installed with plugs tightened; after completion of conductor testing.
3. Conductors:
  - a. Perform insulation resistance test on conductors No. 6 and larger.
    - 1) Utilize 1,000-volt dc megohmmeter for 600-volt insulated conductors and 500-volt dc megohmmeter for 300-volt insulated conductors.
    - 2) Test each conductor with respect to ground and to adjacent conductors for 1 minute.
    - 3) Evaluate ohmic values by comparison with conductors of same length and type.
    - 4) Investigate values less than 50 megohms.
  - b. Verify conductor color coding and circuit identification conforms to Specifications.
4. Molded and Insulated Case Circuit Breakers:
  - a. Inspect and test circuit breakers rated larger than 200 amps and motor circuit protector breakers larger than 100 amps.
  - b. Verify size, rating, and setting with Contract Documents.
  - c. Inspect for proper mounting, conductor size, and integrity of breaker case.
  - d. Verify breaker operates smoothly by opening and closing device.
  - e. Perform insulation resistance test utilizing 1,000-volt dc megohmmeter for 600-volt circuit breakers and 500-volt dc megohmmeter for 240-volt circuit breakers.



- 1) Test pole-to-pole and pole-to-ground of line and load side of breaker with breaker contacts opened for one minute.
  - 2) Test pole-to-pole and pole-to-ground with breaker contacts closed for 1 minute.
  - 3) Verify values comply with NETA ATS, Table 100.1.
  - 4) Investigate deviation of 50 percent or more from adjacent poles and similar breakers. Replace device if it cannot be brought into compliance.
5. Power Circuit Breakers:
    - a. Perform commissioning of power circuit breakers by manufacturer's representative and document by Certificate of Proper Installation.
    - b. Perform insulation resistance test utilizing 1,000-volt dc megohmmeter for 600-volt circuit breakers and 500-volt dc megohmmeter for 240-volt circuit breakers.
      - 1) Test pole-to-pole and pole-to-ground of line and load side of breaker with breaker contacts opened for 1 minute.
      - 2) Test pole-to-pole and pole-to-ground with breaker contacts closed for 1 minute.
      - 3) Verify values comply with NETA ATS, Table 100.1.
      - 4) Investigate deviation of 50 percent or more from adjacent poles and similar breakers. Replace device if it cannot be brought into compliance.
  6. Protective Relaying:
    - a. Inspect relaying for mounting and integrity of relay case.
    - b. Verify protective relay size, rating, and setting with Contract Documents and protective device coordination studies.
  7. Ground Fault Systems:
    - a. Verify zero sequence sensing system is grounded ahead of neutral bonding jumper and ensure ground strap sensing system is grounded through sensing device.
    - b. Ensure neutral ground conductor is solidly grounded.
    - c. Verify zero sequence device settings match settings provided from protective relay coordination study.
    - d. Test neutral insulation resistance with neutral bonding jumper link removed to ensure that resistance is greater than 1 megohm.
  8. Grounding Systems:
    - a. Inspect equipment, ground bus and circuit grounds in motor control centers, switchboards, panelboards, and switchgear for proper connection.
    - b. Inspect grounding electrode and ground rings for proper connection.
    - c. Where exothermic-weld connections are used, verify molds were fully filled and proper bonding was obtained.
    - d. Perform Fall-of-Potential Test in accordance with IEEE 81, Section 8.2.1.5 for measurement of main ground system's resistance. Main ground electrode system resistance to ground shall not be greater than 1 ohm.
    - e. Perform two-point direct resistance test in accordance with IEEE 81, Section 8.2.1.1 for measurement of ground resistance between grounding electrode system and equipment frames and system neutrals. Equipment ground resistance shall not exceed main ground system resistance by 0.25 ohms.
  9. Dry Type Transformers:
    - a. Inspect for visual damage to connections, conductors, and insulators.
    - b. Verify proper winding connections and termination torque level in accordance with NETA ATS, Table 100.12, unless specified otherwise by manufacturer.
    - c. Ensure proper ventilation and air circulation to maintain proper cooling of transformer core.
    - d. Insulation Resistance Test:

- 1) Perform on transformers larger than 10 kVA with applied megohmmeter dc voltage in accordance with NETA ATS, Table 100.5 for phase-to-phase and phase-to-ground for 10 minutes.
  - 2) Record resistance values for 30 seconds, 1 minute, and 10 minutes.
  - 3) Compare results with NETA ATS, Table 100.14 after making temperature corrections and between adjacent coils.
  - 4) Results shall be within published values and within 1 percent of adjacent windings.
  - 5) Verify proper secondary line and phase voltage based on no-load condition, actual primary voltage, and published transformer ratio.
10. Panelboards:
- a. Inspect for defects and physical damage, labeling, and nameplate compliance with Contract Documents.
  - b. Exercise and perform operational tests of mechanical components and other operable devices in accordance with manufacturer's instruction manual.
  - c. Check panelboard mounting, working clearances, and alignment and fit of components.
11. Switchboards:
- a. Inspect for damage to enclosure, door mechanisms, and insulators.
  - b. Inspect for defects and physical damage, labeling, and nameplate compliance with Contract Documents.
  - c. Verify switchboard has been secured per manufacturer's installation instructions.
  - d. Verify gaps between switchboard and equipment pad have been appropriately grouted.
  - e. Check working clearances, and alignment and fit of components.
  - f. Ensure conduits have been filled with duct seal putty.
  - g. Verify conductors have been appropriately tagged and color coded, and installed with quantity and sizes shown in Contract Documents.
  - h. Exercise and perform operational tests of mechanical components and other operable devices in accordance with manufacturer's instruction manual.
  - i. Interlocking System:
    - 1) Check by closure attempt of device when door is in OFF or OPEN position or an opening attempt of door when device is in ON or CLOSED position.
    - 2) Where applicable, check key interlocking systems for key captivity when device is in ON or CLOSED position, key removal when device is in ON or CLOSED position, closure attempt of device when key has been removed and correct number of keys in relationship to number of lock cylinders.
  - j. Verify fuse and circuit breaker ratings, sizes, and types conform to those specified.
    - 1) Check bus and cable connections for high resistance by low resistance ohmmeter and calibrated torque wrench applied to bolted joints.
    - 2) Ohmic value measured should be zero, bolt torque level in accordance with NETA ATS, Table 100.12, unless otherwise specified by manufacturer.
  - k. Verify performance of each control device and feature.
    - 1) Compare control wiring to local and remote control and protective devices with elementary diagrams.
    - 2) Ensure proper conductor lacing and bundling, conductor identification, and proper conductor lugs and connections.
    - 3) Perform phasing check on double-ended equipment to ensure proper bus phasing from each source.

1. Perform insulation resistance test utilizing 1,000-volt dc megohmmeter for 600-volt switchboard and 500-volt dc megohmmeter for 240-volt switchboard.
  - 1) Test phase-to-phase and phase-to-ground with breakers in OPEN position for 1 minute.
  - 2) Repeat test for 1 minute with breakers closed.
  - 3) Verify values comply with NETA ATS, Table 100.1 and insulation resistance values equal to, or greater than, ohmic values established by manufacturer.
12. Motor Controls:
  - a. Verify proper size of individual motor starters, and associated overload protection device and short circuit protection based on Contract Documents.
  - b. Check current, potential, and control power transformers for correct size per Contract Documents.
  - c. Verify terminated conductor color matches phase connected.
  - d. Check associated motor starter nameplates for proper identification of equipment title and tag number based on Contract Documents.
  - e. Check for proper conductor lacing and bundling.
  - f. Compare wiring with elementary diagram for interconnection with control devices and proper conductor identification.
  - g. Verify proper conductor lugs and connections.
  - h. Check operation and sequencing of electrical and mechanical interlocks.
    - 1) Make closure attempts for locked open devices and open attempts for locked closed devices.
  - i. Check alignment of position limit switches for proper operation.
  - j. Perform phasing check on double-ended motor control centers to ensure proper bus phasing from each source.

\*\*\*\*\*

NTS: The following is based on automatic transfer switch being furnished by Contractor as part of pump station construction project. Modify if automatic transfer switch is Owner-furnished as part of engine-generator package to indicate Contractor is to support testing done by Owner's start-up agent.

\*\*\*\*\*

13. Automatic Transfer Switches:
  - a. Check doors and panels for proper operation and ensure correct function of interlocks.
    - 1) Check for a positive mechanical and electrical interlock between normal and alternate sources.
  - b. Verify proper operation of manual transfer function of switch.
  - c. Verify settings and operation of control devices and sensors.
  - d. Insulation Resistance Test:
    - 1) Perform on transfer switches larger than 200 amps.
    - 2) Test according to NETA ATS, Table 100.1 for each phase with switch CLOSED in both source positions.
    - 3) Test phase-to-phase and phase-to-ground for 1 minute. Verify values comply with manufacturer's published data.
  - e. Automatic Transfer Tests:
    - 1) Perform by simulating loss of normal power and then return to normal power.
    - 2) In addition, perform by simulating loss of alternate power and simulating single-phase conditions for normal and alternate sources.

- 3) Monitor and verify operation and timing of normal and alternate voltage sensing relays, engine-start sequence, time delay upon transfer and retransfer, engine cool down and shutdown, and interlocks and limit switch functions.

F. Electrical, Instrument, and Controls Performance Testing

- 1. General:
  - a. Perform to demonstrate to Owner that electrical, instrumentation, and controls systems will perform in accordance with Contract Documents and fulfill functional descriptions specified.
  - b. In addition, provide supplies and labor in support of demonstrating the performance of other systems provided and installed as part of the Project.
  - c. Tests shall establish that installation conforms to requirements of NFPA 70, NFPA 70E, NFPA 101, and IEEE C2.
- 2. Switchboards and Motor Controls:
  - a. Demonstrate device and main circuit breaker interlocking system associated with a main-tie-main switchboard configuration with automatic transfer control system that only two of the main-tie-main breakers can be closed at a given time.
  - b. Demonstrate automatic transfer features and function described under automatic transfer switch paragraph below.
  - c. Demonstrate function of each control device and feature as it relates to demonstrating overall performance of Project.
  - d. Compare control wiring to local and remote control and protective devices with elementary diagrams.
  - e. During transfer between normal and alternative sources, confirm as a point that bus phasing from each source and associated rotation of pumps is the same.

\*\*\*\*\*

NTS: The following is based on automatic transfer switch being furnished by Contractor as part of pump station construction project. Modify if automatic transfer switch is Owner-furnished as part of the engine-generator package to indicate Contractor is to support testing done by Owner's start-up agent.

\*\*\*\*\*

- 3. Automatic Transfer Switches:
  - a. Demonstrate automatic transfer by simulating loss of normal power and then return to normal power.
  - b. Demonstrate automatic transfer by simulating loss of alternate power and simulating single-phase conditions for normal and alternate sources.
  - c. Monitor and verify operation and timing of normal and alternate voltage sensing relays, engine-start sequence, time delay upon transfer and retransfer, interlocks and limit switch functions, and engine cool down and shutdown feature.

\*\*\*\*\*

NTS: The following is based on engine-generator being Owner-furnished equipment. Modify if engine-generator is furnished by Contractor as part of pump station construction project.

\*\*\*\*\*

- 4. Engine Generator System:
  - a. Provide support while Owner's agent demonstrates the operation of the engine-generator system. Contractor shall have personnel on hand to trouble shoot and modify the Contractor provided and installed portions of the automatic transfer

switch and engine-generator system if required to provide for correct operation of these systems.

- b. Owner's agent will demonstrate operation of facility under normal control as would be expected during a utility power outage and operating at plant capacity.
- c. Where multiple generators are installed in parallel, Owner's agent will demonstrate Load Based Generator Controls with expected load combinations to verify response of generators and their associated paralleling features.
- d. Owner's agent will repeat operation of facility when being controlled by backup pump controls during a utility power outage and operating at plant capacity.

G. Instrument Loop Testing:

1. Test each instrument and associated control loop for proper installation, calibration, and adjustment on loop-by-loop and component-by-component basis.
2. Prior to Facility Startup and Performance Evaluation period, inspect, test, and document that associated instrumentation and control equipment is ready for operation.
3. Validate wiring and terminations from field instrument to operator interfaces and control system is correct and functions as intended.
4. Where actual process variables are not practical to use in testing, simulate the process value in such a manner as to represent the actual process.
5. Use loop status reports to organize and track inspection, adjustment, and calibration of each loop. Loop status reports shall include as a minimum the following field:
  - a. Project name.
  - b. Loop number.
  - c. Tag number for each component.
  - d. Calibrate instruments to specified values according to manufacturer's published procedures for application in which they are to operate.
  - e. Each calibrated instrument shall have the calibration documented on a Instrument Calibration Sheet that includes as a minimum the following fields:
    - 1) Project name.
    - 2) Loop number.
    - 3) Component tag number.
    - 4) Component code number.
    - 5) Manufacturer for elements.
    - 6) Model number/serial number.
    - 7) Summary of functional requirements, for example:
      - a) Indicators, scale, ranges, and engineering units.
      - b) Transmitters/converters, input, and output ranges.
      - c) Computing elements' function.
      - d) Controllers, action (direct/reverse), and control modes (PID).
      - e) Switching elements, unit range, differential (fixed/adjustable), reset (auto/manual).
    - 8) Example of calibration features to include as a minimum:
      - a) Analog Devices: Actual inputs and outputs at 0, 10, 50, and 100 percent of span, rising and falling.
      - b) Discrete Devices: Actual trip points and reset points.
      - c) Controllers: Mode settings (PID).
    - 9) Space for comments.
  - f. Instruments that cannot be field calibrated shall bear seal of reputable laboratory certifying instrument has been calibrated to standard endorsed by the NIST.

- g. Check Offs/Sign Offs for Each Component:
  - 1) Tag/identification.
  - 2) Installation.
  - 3) Termination wiring.
  - 4) Termination tubing.
  - 5) Calibration/adjustment.
- h. Check Offs/Sign Offs for the Loop:
  - 1) Panel interface terminations.
  - 2) I/O interface terminations with [PLCs,] [RTUs].
  - 3) I/O Signals for [PLCs,] [RTUs] are Operational: Received/sent, processed, and adjusted.
  - 4) Total loop operational.
- i. Space for comments.
- j. Sign status reports after they have successfully completed and submit for approval, prior to scheduling performance demonstrations.

H. Instrument Loop Demonstration:

- 1. Demonstrate each instrument and associated control loop for proper operation, calibration, and adjustment on loop-by-loop and component-by-component basis.
- 2. Demonstrate entire control system performs functions described in Contract Documents.
- 3. Where actual process variables are not practical to use in testing, simulate process value in such a manner as to represent the actual process.
- 4. Document on loop status reports used for functional testing to organize and ensure a complete demonstration of the system.
- 5. Specific Pump Controls Demonstration:
  - a. Perform the following tests with PLC energized and pump starters or VFDs in OFF position.
  - b. Verify operation of control system by monitoring run input signal to pump starters or VFDs.
  - c. Use calibrated gauge and air pump to simulate input from bubbler tube or captive air system level element.
  - d. Prior to starting, measure and record location of bubbler tube or level element air outlet with respect to wetwell floor or top of wetwell cover.
  - e. Verify control system level readings match input signal through entire range of operation.
  - f. Verify control setpoints for pump ON-OFF function and VFD speed control over wetwell level operating range.
  - g. Simulate a rising and falling wet level over several cycles and verify lead and lag pumps switch sequence as designed.
  - h. Wet Weather, Dry Weather Wetwell Pump Stations:
    - 1) Simulate overflow to wet weather wetwell and demonstrate operation of wet weather pumps and sequencing or lockout of dry weather pumps, as specified.
    - 2) Simulate a return to dry weather conditions and return of control and operation to dry weather pumps.
- 6. For bubbler systems, verify high and low level alarms and primary and back up pump start-stop functions and setpoints.
- 7. For systems with float switches, manually tilt high and low level float switches and verify alarm and pump start-stop functions and setpoints.

8. Demonstrate operation of air compressors for bubbler tube or captive air systems, as applicable to Project.
    - a. Demonstrate compressors automatically maintain system pressure and that alternator switches compressors on successive starts.
    - b. Simulate failure of lead compressor and demonstrate lag compressor starts, for both compressors in lead position.
    - c. Demonstrate system low pressure alarm switch and record operation point, if provided as part of the system.
  9. Simulate a PLC failure and demonstrate level switches or floats, as applicable, cycle pump and initiate alarms as specified.
  10. Simulate a pump seal leak, motor over temperature and pump high vibration level (if applicable) by jumpering sensor wire terminals. Verify alarm and shutdown functions occur as specified.
  11. Demonstrate operation of combustible gas detector using a calibration gas provided by the instrument manufacturer.
  12. Demonstrate operation of control panel (if outdoor panel) or building intrusion switches.
- I. PLC SCADA Exchange register
1. Demonstrate that the data specified to be available for transmission to/from the SCADA system is stored in the proper registers in the PLC.
  2. Using the submitted SCADA data exchange table as a guide, step through the actual PLC registers to show the data stored in each register, including value and units.

\*\*\*\*\*

NTS: Delete this section if there is no odor control system on Project, and edit as applicable to type (biofilter or carbon filter) of system used where there is an odor control system.

\*\*\*\*\*

### 3.3 ODOR CONTROL SYSTEM

- A. Perform tasks listed below, as well as other startup and testing functions called for in Odor Control System specification included in Contract Documents.
- B. Common Biofilter and Activated Carbon Odor Control Systems Testing:
  1. Check ductwork and vessels for leaks before loading media into vessels.
  2. Check for leakage at joints and flanges on fan discharge side using a soap solution.
  3. Inspect vessel and duct walls for cracks that might leak.
  4. Listen for audible leaks on suction side of fan.
  5. Fix leaks; continue process until system is free of leaks except for isolated minor leakage at fan shaft seals.
  6. Perform rotation check of odor control fans to verify fan wheels turn correct direction.
  7. Dampers:
    - a. Open and close dampers to demonstrate proper operation.
    - b. Operate manual dampers by hand.
    - c. Use actuator to operate motor-operated dampers.
    - d. Verify damper position lights indicate correct damper position.
  8. Air Balance Test:
    - a. Run an odor control system fan and perform air balancing of duct system.
    - b. Verify system flows with both system fans.

- c. Submit air balance report.
  9. Prime fan scroll and duct drain traps with water.
  10. Load media into vessel(s).
- C. Biofilter Odor Control System Startup and Testing:
1. Demonstrate operation of nutrient feed pumps using water.
  2. Check rotation of recirculation water pumps, fill vessel sump with water, and demonstrate operation of pumps. View recirculation nozzle spray pattern with pump running, odor control fans off, and vessel door or cover open to allow observation.
  3. Demonstrate operation of nutrient and water control panel and its ability to control nutrient feed pumps, recirculation pumps, and make up water fill.
  4. Measure differential pressure across media bed with fan running and recirculation pump off and with recirculation pump on.
  5. Verify control panel and alarm functions. Confirm operation of recirculation water pH analyzer, sump high and low water level alarms, pressure indicators, pressure switches, and flow indicators.
  6. After pump station has been in operation for at least 2 weeks, measure H<sub>2</sub>S concentration of odorous air entering and leaving filter. Confirm filter is meeting specified removal efficiency. Also measure sump water pH and verify it is in expected range. Over an 8-hour period, measure nutrient usage and make-up water flow.
- D. Carbon Filter Odor Control System Startup and Testing:
1. Measure differential pressure across media bed with fan running.
  2. After pump station has been in operation for at least 2 weeks, measure H<sub>2</sub>S concentration of odorous air entering and leaving filter. Confirm filter is meeting specified removal efficiency.

END OF SECTION



Pump Station No. \_\_\_\_\_

Date: \_\_\_\_\_

City of Baton Rouge  
 Parish of East Baton Rouge  
 Department of Public Works  
 Wastewater Treatment and Disposal Division  
**PUMP STATION DEMONSTRATION CHECK LIST**  
 (Use multiple pages if more than 4 pumps)

DATE \_\_\_\_\_

NO. OF INSPECTIONS \_\_\_\_\_

STATION NO: \_\_\_\_\_

NO. OF PUMPS \_\_\_\_\_

GENERAL CONTRACTOR \_\_\_\_\_

ELECTRICAL CONTRACTOR \_\_\_\_\_

ENGINEER \_\_\_\_\_

PLUMBER (for RPBA) \_\_\_\_\_

ELECTRIAL PROVIDER \_\_\_\_\_ METER# \_\_\_\_\_

PRIMARY VOLTAGE \_\_\_\_\_ VAC \_\_\_\_\_ Phase

WATER PROVIDER \_\_\_\_\_ METER/ACCT NO. \_\_\_\_\_

MOTOR VOLTAGE PUMP # 1 \_\_\_\_\_ VAC \_\_\_\_\_ MOTOR SERIAL NO. PUMP # 1 \_\_\_\_\_  
 NAMEPLATE FLA. \_\_\_\_\_ PUMP MOTOR SIZE \_\_\_\_\_ PUMP MOTOR MFG \_\_\_\_\_  
 PUMP MFG: \_\_\_\_\_ DISCHARGE SIZE \_\_\_\_\_ PUMP #1 SERIAL NO. \_\_\_\_\_

MOTOR VOLTAGE PUMP # 2 \_\_\_\_\_ VAC \_\_\_\_\_ MOTOR SERIAL NO. PUMP # 2 \_\_\_\_\_  
 NAMEPLATE FLA. \_\_\_\_\_ PUMP MOTOR SIZE \_\_\_\_\_ HP PUMP MOTOR MFG \_\_\_\_\_  
 PUMP MFG: \_\_\_\_\_ DISCHARGE SIZE \_\_\_\_\_ PUMP #2 SERIAL NO. \_\_\_\_\_

MOTOR VOLTAGE PUMP # 3 \_\_\_\_\_ MOTOR SERIAL NO. PUMP # 3 \_\_\_\_\_  
 NAMEPLATE FLA. \_\_\_\_\_ PUMP MOTOR SIZE \_\_\_\_\_ HP PUMP MOTOR MFG \_\_\_\_\_  
 PUMP MFG: \_\_\_\_\_ DISCHARGE SIZE \_\_\_\_\_ PUMP #3 SERIAL NO. \_\_\_\_\_

MOTOR VOLTAGE PUMP # 4 \_\_\_\_\_ MOTOR SERIAL NO. PUMP # 4 \_\_\_\_\_  
 NAMEPLATE FLA. \_\_\_\_\_ PUMP MOTOR SIZE \_\_\_\_\_ HP PUMP MOTOR MFG \_\_\_\_\_  
 PUMP MFG: \_\_\_\_\_ DISCHARGE SIZE \_\_\_\_\_ PUMP #4 SERIAL NO. \_\_\_\_\_

Pump Station No. \_\_\_\_\_

Date: \_\_\_\_\_

**ITEM**

**ACTIVITY**  
**Y/N (NA if Not Applicable)**

**ACTION TAKEN (IF NO)**

**AIR SYSTEM**

- 1- Air Compressors Operate \_\_\_\_\_
- 2- Air Line Pressure Tested: System held 60 psi  
for 1 hour. Complete prior to start up \_\_\_\_\_
- 3- Purge Automatic Functions \_\_\_\_\_
- 4- Purge Manual Functions \_\_\_\_\_
- 5- Compressor Lead-Lag Alternates (bubbler only) \_\_\_\_\_
- 6- Compressor Alternates on Lead Fail (bubbler only) \_\_\_\_\_
- 7- Low Pressure (or Flow) Air Alarm Activates \_\_\_\_\_

**GENERAL CONTROL PANEL**

- 1- Loss of Phase Causes Alarm \_\_\_\_\_
- 2- 100% Plastabond Conduit Used \_\_\_\_\_
- 3- Digital Pressure Meter Present on Panel \_\_\_\_\_
- 4- Panel Heater Operates \_\_\_\_\_
- 5- Panel Heater Thermostat(s) Operate \_\_\_\_\_
- 6- Motor Digital Amp Meters Function \_\_\_\_\_
- 7- Alarm lights function on ALL failures \_\_\_\_\_
- 8- Alarm lights reset \_\_\_\_\_
- 9- Site security light operates \_\_\_\_\_
- 10- Panel Air Conditioner Operates \_\_\_\_\_
- 11- Flow Meter Functions \_\_\_\_\_
- 12- PLC Failure Simulated - Pumps Operate on  
Level Floats or Switches \_\_\_\_\_
- 13- Room in panel for future SCADA transmitter \_\_\_\_\_
- 14- Seal offs installed and filled \_\_\_\_\_
- 15- Alarm light on building/panel exterior functions \_\_\_\_\_

**SUMP PUMPS**

- 1- Sump Pumps Provided for Wet Well or Valve Vault \_\_\_\_\_
- 2- Sump Pumps Automatically Controlled by Floats \_\_\_\_\_
- 3- Pumps Operate Properly in Response to Floats \_\_\_\_\_
- 4- Pumps Operate Properly Via On-Off Switches \_\_\_\_\_
- 5- Pump Capacity As Specified (\_\_\_\_\_ gpm) \_\_\_\_\_
- 6- Pump ON setting if float operated \_\_\_\_\_
- 7- Pump OFF setting if float operated \_\_\_\_\_

**GATES AND VALVES (Complete Prior to Startup Demonstration)**

- 1- Manual valves and gates open and close properly \_\_\_\_\_
- 2- Motorized valves and gates open and close using actuator \_\_\_\_\_
- 3- Override handwheel functions for motorized valves/gates \_\_\_\_\_
- 4- OPEN and CLOSED lights operate properly \_\_\_\_\_
- 5- Gates leak tested and meet leakage criteria \_\_\_\_\_

Commissioning Personnel Initials: \_\_\_\_\_ Owner \_\_\_\_\_ Contractor \_\_\_\_\_ Elec Contr \_\_\_\_\_ Engr/CM

Pump Station No. \_\_\_\_\_

Date: \_\_\_\_\_

<b><u>ITEM</u></b> (Use Multiple Pages for more than 4 Pumps)	<b><u>ACTIVITY</u></b> Y/N (NA if Not Applicable)	<b><u>ACTION TAKEN (IF NO)</u></b>
---	--	------------------------------------

**PUMP NO. \_\_**

- |   |       |       |
|---|-------|-------|
| 1- H.O.A. Switch operates                   | _____ | _____ |
| 2- Simulated High Winding Temp Causes Alarm | _____ | _____ |
| 3- Simulated Seal Failure Causes Alarm      | _____ | _____ |
| 4- Pump elapsed time meter function s       | _____ | _____ |
| 5- Pump running light illuminates           | _____ | _____ |
| 6- Pump starts on High Level Switch         | _____ | _____ |
| 7- Pump stops on Low Level Switch           | _____ | _____ |
| 8- Pump overload relay operates             | _____ | _____ |
| 9- Pump stops on High Head                  | _____ | _____ |

**PUMP NO. \_\_**

- |   |       |       |
|---|-------|-------|
| 1- H.O.A. Switch operates                   | _____ | _____ |
| 2- Simulated High Winding Temp Causes Alarm | _____ | _____ |
| 3- Simulated Seal Failure Causes Alarm      | _____ | _____ |
| 4- Pump elapsed time meter function s       | _____ | _____ |
| 5- Pump running light illuminates           | _____ | _____ |
| 6- Pump starts on High Level Switch         | _____ | _____ |
| 7- Pump stops on Low Level Switch           | _____ | _____ |
| 8- Pump overload relay operates             | _____ | _____ |
| 9- Pump stops on High Head                  | _____ | _____ |

**PUMP NO. \_\_**

- |   |       |       |
|---|-------|-------|
| 1- H.O.A. Switch operates                   | _____ | _____ |
| 2- Simulated High Winding Temp Causes Alarm | _____ | _____ |
| 3- Simulated Seal Failure Causes Alarm      | _____ | _____ |
| 4- Pump elapsed time meter function s       | _____ | _____ |
| 5- Pump running light illuminates           | _____ | _____ |
| 6- Pump starts on High Level Switch         | _____ | _____ |
| 7- Pump stops on Low Level Switch           | _____ | _____ |
| 8- Pump overload relay operates             | _____ | _____ |
| 9- Pump stops on High Head                  | _____ | _____ |

**PUMP NO. \_\_**

- |   |       |       |
|---|-------|-------|
| 1- H.O.A. Switch operates                   | _____ | _____ |
| 2- Simulated High Winding Temp Causes Alarm | _____ | _____ |
| 3- Simulated Seal Failure Causes Alarm      | _____ | _____ |
| 4- Pump elapsed time meter function s       | _____ | _____ |
| 5- Pump running light illuminates           | _____ | _____ |
| 6- Pump starts on High Level Switch         | _____ | _____ |
| 7- Pump stops on Low Level Switch           | _____ | _____ |
| 8- Pump overload relay operates             | _____ | _____ |
| 9- Pump stops on High Head                  | _____ | _____ |

Commissioning Personnel Initials: \_\_\_\_\_ Owner \_\_\_\_\_ Contractor \_\_\_\_\_ Elec Contr \_\_\_\_\_ Engr/CM

Pump Station No. \_\_\_\_\_

Date: \_\_\_\_\_

**ITEM**

**ACTIVITY**  
Y/N (NA if Not Applicable)

**ACTION TAKEN (IF NO)**

**RECORD WET WELL GAUGE ELEVATIONS**

- 1- PLC or Float Low Level alarm is. \_\_\_\_\_
- 2- Common stop is. \_\_\_\_\_
- 3- Start Lead Pump is. \_\_\_\_\_
- 4- Start 1<sup>st</sup> lag is. \_\_\_\_\_
- 5- Start 2<sup>nd</sup> lag is. \_\_\_\_\_
- 6- Start 3<sup>rd</sup> lag is. \_\_\_\_\_
- 7- PLC or Float High Level alarm is. \_\_\_\_\_
- 8- Elevation at Bottom of Air Line  
& How Measured \_\_\_\_\_
- 9- Back up low level float \_\_\_ or low level  
switch \_\_\_ setting is., \_\_\_\_\_
- 10- Back up high level float \_\_\_ or low level  
switch \_\_\_ setting is., \_\_\_\_\_

**SUBMERSIBLE PUMPS**

- 1- Pump travels properly on guide rails  
when raised or lowered  
(check prior to start up) \_\_\_\_\_
- 2- Evidence of leaks at point where pump  
connects to pump base elbow \_\_\_\_\_
- 3- Evidence of Pump cavitation or vortexing \_\_\_\_\_
- 4- Air release valve installed \_\_\_\_\_
- 5- Block valve at Force Main \_\_\_\_\_
- 6- Check valve limit switch \_\_\_\_\_
- 7- Pressure gauge installed on each pump \_\_\_\_\_
- 8- Pressure transmitter installed on force main \_\_\_\_\_

**ODOR CONTROL SYSTEM**

- 1- System checked for leaks \_\_\_\_\_
- 2- Fan rotation checked and verified \_\_\_\_\_
- 3- Air balance complete \_\_\_\_\_
- 4- Isolation dampers open and close correctly \_\_\_\_\_
- 5- Drain traps primed \_\_\_\_\_
- 6- Media loaded into vessels \_\_\_\_\_
- 7- Water recirculation pump and sprays operate properly \_\_\_\_\_
- 8- Nutrient feed pump operates correctly \_\_\_\_\_
- 9- Make up water controls level in sump \_\_\_\_\_
- 10- Media bed differential pressure is \_\_\_\_\_
- 11- Control panel operation and alarm functions verified \_\_\_\_\_

Commissioning Personnel Initials: \_\_\_\_\_ Owner \_\_\_\_\_ Contractor \_\_\_\_\_ Elec Contr \_\_\_\_\_ Engr/CM

Pump Station No. \_\_\_\_\_

Date: \_\_\_\_\_

**ITEM**

**ACTIVITY**  
Y/N (NA if Not Applicable)

**ACTION TAKEN (IF NO)**

**SWTCHBOARD**

- 1- Conductors color coded and labeled \_\_\_\_\_
- 2- Door closure or key interlock system operates correctly \_\_\_\_\_
- 3- Phasing checked on double-ended equipment \_\_\_\_\_

**MOTOR CONTROL CENTER**

- 1- Conductors color coded and labeled \_\_\_\_\_
- 2- Door closure interlock system operates correctly \_\_\_\_\_
- 3- Phasing checked on double-ended equipment \_\_\_\_\_

**METER READINGS**

**MEGOHM READINGS** (Use Multiple Pages for more than 4 Pumps)

Pump No. 1

Leg A- GND \_\_\_\_\_ Leg B- GND \_\_\_\_\_ Leg C- GND \_\_\_\_\_

A-B \_\_\_\_\_ B-C \_\_\_\_\_ C-A \_\_\_\_\_

Pump No. 2

Leg A- GND \_\_\_\_\_ Leg B- GND \_\_\_\_\_ Leg C- GND \_\_\_\_\_

A-B \_\_\_\_\_ B-C \_\_\_\_\_ C-A \_\_\_\_\_

Pump No. 3

Leg A- GND \_\_\_\_\_ Leg B- GND \_\_\_\_\_ Leg C- GND \_\_\_\_\_

A-B \_\_\_\_\_ B-C \_\_\_\_\_ C-A \_\_\_\_\_

Pump No. 4

Leg A- GND \_\_\_\_\_ Leg B- GND \_\_\_\_\_ Leg C- GND \_\_\_\_\_

A-B \_\_\_\_\_ B-C \_\_\_\_\_ C-A \_\_\_\_\_

Pump Station No. \_\_\_\_\_

Date: \_\_\_\_\_

**PUMPS RUNNING**

Pump No. 1 (if variable speed, pump speed at 100 %)

AMP Readings: Leg 1 \_\_\_\_\_ Leg 2 \_\_\_\_\_ Leg 3 \_\_\_\_\_

Voltage: AB \_\_\_\_\_ VAC AC \_\_\_\_\_ VAC BC \_\_\_\_\_ VAC

Pump Head: Lift from water surface to gauge \_\_\_\_\_ ft. + gauge pressure \_\_\_\_\_ psi x 2.31 = \_\_\_\_\_ feet  
Calculated \_\_\_\_\_ (based on wet well volume) or Measured \_\_\_\_\_ Flow \_\_\_\_\_ gpm

Pump No. 2 (if variable speed, pump speed at 100%)

AMP Readings: Leg 1 \_\_\_\_\_ Leg 2 \_\_\_\_\_ Leg 3 \_\_\_\_\_

Voltage: AB \_\_\_\_\_ VAC AC \_\_\_\_\_ VAC BC \_\_\_\_\_ VAC

Pump Head: Lift from water surface to gauge \_\_\_\_\_ ft. + gauge pressure \_\_\_\_\_ psi x 2.31 = \_\_\_\_\_ feet  
Calculated \_\_\_\_\_ (based on wet well volume) or Measured \_\_\_\_\_ Flow \_\_\_\_\_ gpm

Pump No. 3 (if variable speed, pump speed at 100%)

AMP Readings: Leg 1 \_\_\_\_\_ Leg 2 \_\_\_\_\_ Leg 3 \_\_\_\_\_

Voltage: AB \_\_\_\_\_ VAC AC \_\_\_\_\_ VAC BC \_\_\_\_\_ VAC

Pump Head: Lift from water surface to gauge \_\_\_\_\_ ft. + gauge pressure \_\_\_\_\_ psi x 2.31 = \_\_\_\_\_ feet  
Calculated \_\_\_\_\_ (based on wet well volume) or Measured \_\_\_\_\_ Flow \_\_\_\_\_ gpm

Pump No. 4 (if variable speed, pump speed at 100%)

AMP Readings: Leg 1 \_\_\_\_\_ Leg 2 \_\_\_\_\_ Leg 3 \_\_\_\_\_

Voltage: AB \_\_\_\_\_ VAC AC \_\_\_\_\_ VAC BC \_\_\_\_\_ VAC

Pump Head: Lift from water surface to gauge \_\_\_\_\_ ft. + gauge pressure \_\_\_\_\_ psi x 2.31 = \_\_\_\_\_ feet  
Calculated \_\_\_\_\_ (based on wet well volume) or Measured \_\_\_\_\_ Flow \_\_\_\_\_ gpm

Pump Station No. \_\_\_\_\_

Date: \_\_\_\_\_

**ITEM**

**ACTIVITY**  
Y/N (NA if Not Applicable)

**ACTION TAKEN(IF NO)**

**TELEMETRY SIGNALS**

Data Exchange Table Submitted and Accepted \_\_\_\_\_

**PUMP ALTERNATOR**

1- After each run, Alternator switches the  
Lead pump \_\_\_\_\_

2- Alternator switches Lead Pump  
designation when designated Lead  
Pump is turned Off (check each pump) \_\_\_\_\_

**EMERGENCY POWER**

- 1- Breakers or ATS switch on utility failure \_\_\_\_\_
- 2- Breakers or ATS switch on loss of phase \_\_\_\_\_
- 3- Return to Utility source occurs on return of power \_\_\_\_\_
- 4- Return to Utility source occurs on return of phase \_\_\_\_\_
- 5- Delay on return of power or phase is set at \_\_\_\_\_ minutes
- 6- Engine cool down timer set at \_\_\_\_\_ minutes
- 7- Synchronizing of generators occurs properly \_\_\_\_\_

**OTHER ITEMS TO BE CHECKED**

- 1- Access Road Complete \_\_\_\_\_
- 2- Water To Station: \_\_\_\_\_
- 3- Fence is complete \_\_\_\_\_
- 4- Are there any leaks in pipes, station walls, or floor: \_\_\_\_\_
- 5- Are all electrical breakers and pump switches labeled: \_\_\_\_\_
- 6- Are there any holes or wash out: \_\_\_\_\_
- 7- Does the building need priming or painting inside or out: \_\_\_\_\_
- 8- Are there any other items that need to done or addressed: \_\_\_\_\_
- 9- Are spare parts transferred to DPW: \_\_\_\_\_
- 10- Are O&M Manuals submitted: \_\_\_\_\_
- 11- Has training been completed: \_\_\_\_\_

**Provide and attach copies of manufacturer’s start up checklists, in addition to this check list, where such checklists are provided by the manufacturer’s representative.**

\_\_\_\_\_  
Owner

\_\_\_\_\_  
Electrical Contractor

\_\_\_\_\_  
Engineer

\_\_\_\_\_  
General Contractor

\_\_\_\_\_  
Date

**Attachment I**  
**Pump Station Design Checklists**

---



# Preliminary Design (30% Design) Checklist

---

## Preliminary Design Report Contents

- Process Flow Diagrams (PFDs) for stations with four or more pumps
- Flow Stream IDs, Legend, Abbreviations
- Preliminary Equipment List/Data Sheets
- Preliminary Site Plan(s)
- Control Philosophy
- Structural Design Concept
- Final Geotechnical Report
- HVAC/Plumbing Design Concepts
- Electrical Design Concepts
- Material Selection
- Quantity Take-Offs for Construction Cost Estimate by Project Manager

---

Lead Engineer Signature

---

Date

---

Quality Control (QC) Reviewer Signature

---

Date

## Preliminary Design Checklist: Process Mechanical

- Prepare PFD and written description of the control philosophy for each process.
- Select and size all major process equipment including pumps. Prepare and review sizing calculations.
- Prepare equipment list with sizing for major equipment.
- Prepare preliminary hand sketches for equipment arrangements.
- Coordinate with the owner on preferences of equipment manufacturer and processes.
- Obtain vendor price quotes for all major process equipment.
- Review capacity and condition of all existing processes and equipment to remain in service where appropriate. Assign capacity to existing equipment and process.



Lead Engineer Signature	Date
-------------------------	------

QC Reviewer Signature	Date
-----------------------	------

**Preliminary Design Checklist: Architectural (If New Building or Existing Building Renovations Required)**

- ❑ Establish preliminary electrical building layout and size.
- ❑ Establish architectural theme for exterior of building.
- ❑ Select interior and exterior construction materials for each building (brick, wood, precast concrete, stucco).
- ❑ Select roof type (standing seam metal roof preferred), slope, and roof support system (wood truss, bar joist, concrete beams) for each building.
- ❑ Assign code classification to each building. Meet with local code official to review code classifications.
- ❑ Perform a code review of existing facilities that require retrofit/rehabilitation to identify areas where the facilities do not meet current codes. Develop a plan to bring existing facilities into code compliance where necessary. Compile list of chemicals and amounts to be used. Coordinate with other disciplines (mechanical and electrical) to resolve code compliance issues specific to these disciplines (i.e., National Electrical Code and National Fire Protection Association 820 issues).
- ❑ Prepare preliminary building layouts (hand sketches or CAD equivalent including plans, sections, and elevations).
- ❑ Develop alternative layouts if required.

Lead Engineer Signature	Date
-------------------------	------

QC Reviewer Signature	Date
-----------------------	------



### Preliminary Design Checklist: Geotechnical

- Determine site specific geotechnical conditions for each facility and structure.
- Develop specific foundation requirements.
- Develop other project specific geotechnical requirements.
- Verify constructability (shoring and bracing requirements, dewatering issues).
- Conduct final geotechnical investigations.
- Obtain data on soil corrosivity.

---

Lead Engineer Signature

Date

---

QC Reviewer Signature

Date

### Preliminary Design Checklist: Civil

- Coordinate with surveyors; define surveyors' scope of work.
- Coordinate with geotechnical engineer on boring locations; record location onsite drawings.
- Develop site plan(s), including building footprints, to validate design concepts.
- Confirm adequacy of topographical and boundary mapping.
- Confirm that site coordinate system is appropriate.
- Evaluate legal, ownership, permitting, zoning constraints.
- Determine structure size, location, orientation.
- Layout roadways/truck access corridors and define maneuvering requirements (design vehicle).
- Determine emergency vehicle access requirements.
- Evaluate flood plain impacts and constraints.
- Locate storm water management facilities.
- Locate utility and piping corridors (horizontal and vertical).
- Locate Contractor storage and staging areas.
- Develop alternative layouts for evaluation as required.
- Confirm existing site zoning is correct.
- Review existing pavement condition; develop plan for improvement if required.
- Develop preliminary erosion control plan for project. Determine if erosion control ponds are required; locate ponds onsite plan drawings as required.



- ❑ Prepare preliminary storm water calculations suitable for submission to local site permitting authorities.
- ❑ Develop preliminary storm water control concepts (swales, curb, and gutter).
- ❑ Meet with local storm water and erosion and sediment control agency to determine permitting requirements for site plans, and impact of requirements on preparation of contract documents. Document findings.
- ❑ Identify environmentally sensitive areas such as wetlands, hazardous waste areas, etc.
- ❑ Set preliminary finished floor levels for new structures.
- ❑ Establish preliminary finished grades, overall major surfaces, road profiles, etc.
- ❑ Iterate preliminary surfaces and structures to optimize earthwork if necessary.
- ❑ Identify major open channel and outfall pipe corridors.

Lead Engineer Signature	Date
-------------------------	------

QC Reviewer Signature	Date
-----------------------	------

### Preliminary Design Checklist: Structural

- ❑ Coordinate with architectural discipline on the selection of building concepts, if building required.
- ❑ Consult with lead process engineer on building/structure layouts. Check to make sure building layouts do not require unnecessarily difficult structural design or the use of unnecessary high-cost structural systems.
- ❑ Where existing building or structures require upgrades or modifications, conduct a feasibility study to make sure the proposed modifications can be implemented cost-effectively.
- ❑ Evaluate any structural problems associated with any existing pump station facilities to be modified in this project. Describe the problem and a recommended solution. Estimate the construction cost of fixing the problem.
- ❑ Develop building foundation and structure concepts based on Preliminary building/structure layouts.

Lead Engineer Signature	Date
-------------------------	------

QC Reviewer Signature	Date
-----------------------	------



## Preliminary Design Checklist: Instrumentation and Control

- Coordinate with the process engineer(s) to prepare a PFD for each pump station with four or more pumps. Information to be included on each PFD includes at a minimum:
  - Process configuration
  - Flow streams
  - Valve and gate locations (manual and powered)
  - Chemical additions points/types, if required
  - Process equipment location/type including packaged control panels and variable-speed drives
  - Flowmeters and other process control devices
- Develop equipment/instrument tag numbering, naming, and abbreviation conventions per the Equipment and Instrument Tagging Requirements.
- Work with Process Engineer to prepare written operational description of each pump station.
- Develop overall control philosophy.

---

Lead Engineer Signature

---

Date

---

QC Reviewer Signature

---

Date

## Preliminary Design Checklist: HVAC (If HVAC Required) and Plumbing

- Select type of ventilation system to be used in electrical buildings (inlet air tempered with both inlet and outlet fans, simple exhaust fan system), if required.
- Select type of HVAC equipment to be used.
- Select type of A/C system to be used in electrical buildings/control panels, if required (variable air volume system, zoned constant air volume system).
- Coordinate with architectural discipline to establish design R-values for all exterior building walls.
- Perform a ventilation code review of existing facilities that require retrofit/rehabilitation to identify areas where the facilities do not meet current codes. Develop a plan to bring existing facilities into code compliance where necessary. Coordinate with other disciplines (architectural and electrical) to resolve code compliance issues.



- Coordinate required plumbing walls and access locations with Architect.
- Coordinate with local fire marshal and Architect to determine requirements for sprinklers and fire water.
- Coordinate with local water utility on water availability (quantity, pressure).
- Calculate water requirements and sanitary sewer flows.

---

Lead Engineer Signature

---

Date

---

QC Reviewer Signature

---

Date

### Preliminary Design Checklist: Electrical

- Coordination with Electrical Utility to provide electric power to the pump station site with the voltage and capacity needed for preliminary loads.
- Prepare preliminary overall one-line diagram for pump stations with four or more pumps.
- Coordinate with lead process engineers to size equipment motors.
- Prepare preliminary load calculations and submit to Program Manager on Electrical Load Estimate Sheet.
- Obtain preliminary generator sizing from Program Manager.
- Determine location of generator.
- Size electrical building, if required.
- Determine number of electrical feeds to be provided to facility. Coordinate with local power utility to determine locations of power feeds, voltage, billing details (peak usage rates), requirements for reduced voltage starters, substation requirements.
- Develop concept for location of electrical equipment (indoor versus outdoor).
- Determine redundancy requirements for power supplies and power distribution.
- Establish preferred voltages for power distribution and utilization equipment.
- Coordinate with I&C discipline to determine where control system components will be installed (i.e., in electrical building, in field-mounted panel)
- Perform an electrical code review of existing facilities that require retrofit/rehabilitation to identify areas where the facilities do not meet current codes. Develop a plan to bring existing facilities into code compliance where necessary.



Coordinate with other disciplines (architectural, mechanical) to resolve code compliance issues specific to these disciplines.

- ❑ Develop preliminary schedule of hazardous and corrosive locations.

---

Lead Engineer Signature

---

Date

---

QC Reviewer Signature

---

Date

# 60% Design Checklist

---

## 60% Design Review Package Contents (Typical)

- Final PFDs
- Completed P&IDs with instruments
- Typical control schematics
- Equipment list
- Site plan
- Preliminary electrical one-lines for stations with four or more pumps
- Building floor plans/elevations (if required)
- Exterior renderings/isometrics (if required)
- Standard specifications and draft special provisions
- Drawing list for Construction Documents
- Quantity take-offs for construction cost estimate by Project Manager

---

Lead Engineer Signature

---

Date

---

Quality Control (QC) Reviewer Signature

---

Date

## 60% Design Checklist: Process Mechanical

- Calculate the hydraulic profile for all major gravity process pipelines and hydraulic structures, if in Engineer's scope.
- Prepare structure layouts (plans and one section each).
- Assemble catalog cuts for all major process equipment, including odor control.
- Complete equipment data sheets or equipment list on all major equipment items, including odor control.
- Confirm final design drawing list.
- Prepare specifications list.
- Prepare draft equipment specifications.
- Final equipment sizing and line sizing calculations.





- Final equipment selection (type, size, weight, arrangement).
- Select piping materials.

Lead Engineer Signature	Date
QC Reviewer Signature	Date

**60% Design Checklist: Architectural (If New Building or Existing Building Renovations Required)**

- Develop building floor plans and elevations for all buildings. Use 3-D CAD tools if available.
- Coordinate with I&C and electrical disciplines to size and locate electrical and control equipment.
- Coordinate with the mechanical discipline to select the type of HVAC equipment, locate HVAC equipment rooms (if needed), determine space requirements and routing for ductwork if required, and establish design R-values for all exterior walls.
- Coordinate with structural engineer to define the structural design concepts for the facilities.
- Establish applicable codes for all buildings/structures with local code officials and fire marshal.
- Complete building and fire code analysis.
- Meet with local code official to review floor plans.
- Confirm drawing list for final design.
- Develop specifications list.

Lead Engineer Signature	Date
QC Reviewer Signature	Date



### 60% Design Checklist: Civil

- Freeze civil design concept
  - Structure, road, and major site element horizontal locations
  - Structure floor/control levels, and finished grades
  - Demolition requirements and limits
  - Contractor staging, storage, access, and offsite access corridors
- Prepare preliminary site grading drawings. Coordinate with geotechnical engineer.
- Download survey data to create site drawing files for final design.
- Set final building and structure elevations.
- Layout preliminary yard piping and plant drain layout.
- Provide plan and profile of yard piping, 18 inches and larger.
- Identify corridors for smaller piping and other utilities.
- Show storm water control concepts (swales, curb, and gutter) on the design development drawings.
- Finalize traffic flow, parking, and lay out road access to all buildings and structures.
- Coordinate handicap requirements with architectural discipline and local site plan regulations.
- Confirm final design drawing list.
- Develop specifications list.

Lead Engineer Signature	Date
QC Reviewer Signature	Date



## 60% Design Checklist: Structural

- Coordinate with geotechnical engineer to establish foundation design criteria for proposed facilities. Review geotechnical report and discuss foundation design approach with geotechnical engineer and senior structural reviewer.
- Confirm drawing list for final design.
- Develop specifications list.
- Document structural design concept for each structure and building (if building required). Summarize in a memorandum.
- Prepare preliminary floor plan for all major structures.
- Show wall and slab thickness and dimensions for all structures

---

Lead Engineer Signature

---

Date

---

QC Reviewer Signature

---

Date

## 60% Design Checklist: Instrumentation and Control

- Prepare preliminary input/output (I/O) count.
- Complete P&IDs for stations with four or more pumps.
- Prepare final CAD-based P&ID drawings including loop numbers and all instrumentation.
- Summarize I&C system design philosophy for each major process. Include a description of the field elements to be used for each application and preliminary set points for major I&C elements.
- Coordinate with HVAC engineer regarding control system requirements.
- Define control interfaces for all package systems with local controls, including AFDs.
- Develop specifications list.
- Confirm drawing list for final design.
- Finalize typical control diagrams/loop diagrams for each type of control scheme to be used.

---

Lead Engineer Signature

---

Date

---

QC Reviewer Signature

---

Date



## 60% Design Checklist: HVAC (If HVAC Required) and Plumbing

- Prepare sizing calculations for HVAC equipment based on energy code requirements and selected building construction materials. Prepare HVAC equipment data sheets and cut sheets.
- Create ventilation concept drawing (louver locations, fan locations, type of equipment, air flows).
- Confirm drawing list for final design.
- Develop specifications list.
- Identify routing or right-of-way for major duct runs.
- Locate major air handling equipment.
- Confirm size of mechanical equipment rooms.
- Prepare HVAC system block diagrams.
- Define HVAC system control philosophy.
- Coordinate with civil engineer for potable water and fire water supply and distribution, as well as facility drain system, if required.

---

Lead Engineer Signature

---

Date

---

QC Reviewer Signature

---

Date

## 60% Design Checklist: Electrical

- Coordination with Electrical Utility to provide electric power to the pump station site with the voltage and capacity needed for 60% design loads.
- Prepare preliminary one-line diagrams for proposed facilities with four or more pumps, utilizing Attachment C.
- Coordinate with lead process engineers to size equipment motors.
- Prepare detailed electrical load calculations based on highest horsepower pump manufacturer and submit to Program Manager on Electrical Load Estimate Sheet.
- Obtain generator sizing from Program Manager.
- Prepare installation details for generator and automatic transfer switch (ATS) or automatic transfer control, if multiple generators.
- Determine number of MCCs to be provided, location of MCCs, and equipment to be powered out of each MCC.



- Size electrical building and prepare a preliminary layout of the major electrical equipment located in the electrical building.
- Locate VFDs and confirm sizes.
- Confirm electrical equipment dimensions and layout with vendors, if required.
- Determine equipment requiring uninterruptable power supplies (UPS) and locations of UPS equipment.
- Coordinate with I&C discipline to determine space requirements and locations for control equipment.
- Prepare a design narrative for the electrical design.
- Define/document requirements and concepts for special systems, if required
  - Telephone (including incoming service location, scope of supply, etc.)
  - Data highway (control system)
  - Fire alarm system
- Locate major I/O termination locations, TJBs, control panels.
- Submit load calculations and one-lines to electric utility for review.
- Identify rights-of-way and routing methods for electrical conduit and tray.
- Lay out duct bank system (major runs/manholes). Coordinate with civil yard piping. Locate manholes and handholes.
- Develop detailed lighting concepts; select luminaire types (Coordinate with Architect, if building required)
- Do preliminary lighting layouts and initial lighting calculations.
- Prepare preliminary site lighting layout.
- Coordinate overall control philosophy with I&C.
- Confirm deliverable list for final design.
- Develop specifications list.
- Define hazardous locations (NFPA 820) and document.
- Define corrosive locations and document.

Lead Engineer Signature	Date
QC Reviewer Signature	Date

# Final Design and Contract Documents (90% and 100% Design) Checklists

---

The following checklists present typical design elements that shall be checked and coordinated by the design team during the Final Design and Contract Documents phases. From the Engineer's standpoint, the 90% design submittal shall be ready to bid. The only changes to be made between the 90% and 100% submittal shall be those needed to address final Project Manager and Owner comments.

The checklists are divided into the following three general categories:

- **General:** These items apply to all disciplines, and all lead engineers are responsible for checking the items for their work.
- **Intradiscipline:** These items are designated as mechanical, structural, etc., and the lead engineer for each discipline is responsible for checking the items.
- **Interdiscipline:** These items require coordination among disciplines. The design team members responsible for each of the items shall be identified in the project instructions before construction documents preparation begins.

## General

- Verify that all design calculations have been completed and checked. Checks shall be performed as the calculations are developed.
- Check that north arrows are present and correct.
- Check that drawing scales are present and correct.
- Verify that sheet numbers and names agree with index.
- Verify that sheet, section, and detail references, including standard detail references, are present and correct.
- Verify that details are complete.
- If a reference is made to another discipline's drawing, verify that the item is covered adequately on the other drawing.
- Coordinate drawings and specifications with DPW standard drawings and specifications. If DPW standard drawing/specification applies, reference on drawings and list on drawing/specification index.
- Coordinate drawings and specifications. If a reference is made to see the specifications, verify that the item is adequately specified.
- Are legend symbols and abbreviations, including flow stream IDs, used properly?  
Are additional symbols or abbreviations needed?



- Are equipment tag numbers and names shown and correct?
- Are all dimensions and elevations presented as required and do they agree between drawings?
- Check for interferences within drawings. Examine for interferences within and between all equipment layouts, piping systems, electrical designs, building services, HVAC systems, structural and architectural systems, and control elements.
- Verify that painting requirements are defined for all structures, equipment, and components.
- Check order of drawings.
- Check drawing numbering.
- Check drawing notes.

---

Lead Engineer Signature

---

Date

---

Quality Control (QC) Reviewer Signature

---

Date

### Final Design and Contract Documents Checklist: Process Mechanical

- Update equipment and process design calculations, if required.
- Finalize equipment data sheets; notify team of any changes.
- Define process startup requirements.
- Prepare process plans.
- Prepare yard piping plans. (Coordinate with civil.)
- Develop process sections.
- Prepare equipment/mechanical details.
- Prepare mechanical sections and details.
- Prepare equipment specifications.
- Coordinate equipment specifications with painting, package control system, and electric motor specifications.
- Coordinate variable speed drives with electrical specifications.
- Finalize drawings and specifications.
- Is all equipment located adequately?



- ❑ Are pipe, duct sizes, and elevations (centerline or invert) present as required?
- ❑ Review I&C loop descriptions to confirm that they provide intended functions.
- ❑ Check all pipes entering and leaving a facility and confirm that they are correctly shown on the yard piping drawings and are consistent with the process drawings. Check the size, designation, location, destination, and elevation.
- ❑ Check flow schemes for process piping with the flow schemes shown on the P&IDs.
- ❑ Check all piping for the following:
  - Verify all flow stream IDs with the legend and the pipe schedule.
  - Verify that pipe sizes and elevations are consistent among drawings.
  - Check for correct wall-penetration details.
  - Check pipe supports and support anchoring.
  - Coordinate pipe supports with electrical supports.
  - Confirm that pipe schedule test pressures and materials are proper for the intended service.
  - Check thrust restraint.
  - Verify that clearances allow the piping and appurtenances to be installed and serviced. Verify that distances between buried pipes and clearances from walls are acceptable for proper compaction and installation.
- ❑ Check all valves for the following:
  - Call out valve sizes and numbers.
  - Verify that each valve type is proper and is specified.
  - Confirm that the valve material and pressure rating match the piping rating.
  - Confirm that operator clearance and access is provided.
  - Verify that operators are correctly specified and that type of operator for each valve is clearly shown on drawings or specified.
  - Coordinate power to all valves, when necessary.
  - Confirm control signal requirements for valves with I&C and Electrical.
  - Confirm specified conditions and fail positions for power-operated units.
- ❑ Verify that miscellaneous devices shown on the drawings are specified. Such devices include quick-connects, hoses, nozzles, small valves, strainers, fabricated metal items, and anchors. Verify that titles and numbers used on the drawings are consistent with those in the specs.





- Confirm that I&C primary elements are located on the process mechanical plans and that instrument locations and ranges are appropriate for the intended use.
- Are all pumps and other equipment, valves, instrument sensors, and panels properly identified on the process mechanical sheets? Is the ID the same as on the P&IDs and in the specifications?
- Is there room for moving equipment in and out? Is there sufficient access to and work space around all equipment? Can all valve actuators be accessed? Where hatches are shown, confirm that their size and location will allow equipment removal.
- Has noise attenuation been provided if necessary?
- Verify, where necessary, that equipment is explosion-proof or non-sparking.

Lead Engineer Signature	Date
-------------------------	------

QC Reviewer Signature	Date
-----------------------	------

**Final Design and Contract Documents Checklist: Geotechnical**

- Prepare geotechnical data and information for inclusion in the Contract Documents.

Lead Engineer Signature	Date
-------------------------	------

QC Reviewer Signature	Date
-----------------------	------

**Final Design and Contract Documents Checklist: Civil**

- Verify that information on the plans is sufficient for locating the structures.
- Check the grade at each facility and coordinate grade elevation with doorways, sidewalks, handrails, pipe covers, and driveways.
- Verify that access provisions shown on the site drawings, such as sidewalks and driveways, are suitable for the facility. Confirm that sidewalks match locations of stairs and doorways.
- Coordinate site civil, site electrical, and yard piping. Identify and resolve conflicts.



- Coordinate existing utility interfaces.
- Check that the contractor's staging area is adequate.
- Finalize site layout, including road layout, building locations, and overall grading
  - Demolition
  - Horizontal geometry for new facilities
  - Roadways
  - Fencing, gates, security, and access control
- Set finish floor requirements and grading requirements for structures.
- Prepare storm drain calculations and set piping sizes.
- Verify storm water hydrology, hydraulics, and storm water management facilities.
- Check storm water conveyance system horizontal and vertical controls.
- Develop roadway sections, details, and road profiles and pavement design.
- Develop storm drain profiles.
- Prepare manhole and inlet schedule.
- Locate sidewalks and door pads.
- Prepare fine grading and add spot elevations.
- Prepare civil details.
- Prepare final drawings.
- Prepare final specifications.

---

Lead Engineer Signature

---

Date

---

QC Reviewer Signature

---

Date

### Final Design and Contract Documents Checklist: Architectural (If New Building or Existing Building Renovations Required)

- Produce base plan for production.
- Develop reflected ceiling plan.
- Develop roof plan.



- Develop building sections.
- Prepare final base plan.
- Prepare architectural schedules.
- Prepare final drawings.
- Prepare final specifications.

Lead Engineer Signature	Date
QC Reviewer Signature	Date

**Final Design and Contract Documents Checklist: Structural**

- Cross-check structural dimensions against site layout coordinates.
- Coordinate use of structural notes; be consistent.
- Coordinate structural fill requirements and limits with the geotechnical engineer and the specifications/details. Show limits of granular fill, select fill, and base on structural drawings ONLY if absolutely required by unique conditions.
- Verify that structures have been designed for the type of underlying fill specified.
- Check constructability of structural and architectural features.
- Check piping support and thrust systems and HVAC and electrical support systems.
- Perform final structural design calculations.
- Prepare structure foundation, intermediate, and top plans.
- Prepare building foundation, floor, and roof plans, if required.
- Prepare sections.
- Prepare details, including standard details.
- Prepare final drawings and specifications.

Lead Engineer Signature	Date
QC Reviewer Signature	Date



## Final Design and Contract Documents Checklist: Instrumentation and Control

- Check P&IDs and other I&C sheets for uniformity of presentation, including both graphical and technical detail.
- Are cross references between P&IDs shown and correct?
- Coordinate the I&C components and control panels specified in the equipment specifications with the loop descriptions and the P&IDs.
- Check electrical drawings and schedules for necessary I&C conduits and conductors.
- Coordinate field panel locations and sizes among the discipline drawings to prevent conflicts and provide convenient operator access.
- Review all package control system specifications.
- Prepare control panel sizing, instrument sizing, and installation details.
- Prepare loop descriptions.
- Finalize I/O list.
- Prepare control/loop diagrams.
- Prepare instrument lists and/or instrument data sheets.
- Review and provide input on actuator and package control system specifications.
- Prepare panel elevations.
- Prepare final specifications and drawings.

---

Lead Engineer Signature

---

Date

---

QC Reviewer Signature

---

Date

## Final Design and Contract Documents Checklist: Electrical

- Check that proper site lighting is provided for the required functions, as desired by the Owner.
- Check panel-mounted I&C and/or electrical components (switches, lights, etc.) against control diagrams, specifications, and P&IDs.
- Check conduit routing with mechanical and structural designs, especially embedded conduits.
- Check electrical one-line diagrams against equipment specifications and plans.
- Check motor horsepowers, voltages, phases, and enclosures against equipment specifications.



- Verify, where necessary, that equipment is explosion-proof or non-sparking.
- Check electrical interfaces with existing systems.
- Verify compliance with electrical code requirements.
- Verify that all equipment and devices, including heat tracing and field elements, have power and control conductors.
- Coordinate all circuits and raceways entering and leaving the facilities with the circuit and raceway schedules.
- Review all equipment specifications.
- Prepare short circuit calculations to determine required equipment ratings.
- Prepare final load calculations based on highest horsepower pump manufacturer and provide to Program Manager on Electrical Load Estimate Sheet.
- Verify generator sizing with Program Manager.
- Size major electrical equipment and feeders.
- Coordinate service/metering requirements with electrical utility. Write letter documenting requirements.
- Finalize one-line diagrams.
- Finalize electrical equipment/electrical room sizes.
- Finalize installation details for generator and ATS.
- Prepare site lighting plan, if desired by Owner.
- Prepare duct bank routing and locate manholes and handholes; coordinate with civil discipline.
- Prepare sections for duct banks.
- Develop electrical equipment elevations, layouts, and sizes.
- Finalize electrical room layout.
- Develop and finalize electrical facility plans.
- Prepare motor control diagrams; coordinate with I&C.
- Develop conduit/cable schedules.
- Develop details and legend sheets.
- Develop electrical specifications.
- Prepare AFD specifications.
- Coordinate control diagrams and cable schedules with I&C.
- Prepare lighting/power panel schedules.
- Review I&C and equipment specifications and coordinate with electrical design.



- Finalize specifications.
- Call out hazardous and corrosive locations.

---

Lead Engineer Signature	Date
-------------------------	------

---

QC Reviewer Signature	Date
-----------------------	------

### Final Design and Contract Documents Checklist: HVAC (If HVAC Required) and Plumbing

- Prepare final HVAC equipment sizing, louver sizing, and electric heat load calculations.
- Review HVAC control system with I&C and Electrical.
- Review cooling load calculations and update as required.
- Prepare valve and piping schedules.
- Calculate heat tracing loads.
- Prepare building services standard details.
- Prepare HVAC equipment schedules.
- Develop potable and nonpotable water and drainage system plans.
- Size plumbing equipment.
- Prepare final plumbing, HVAC, and fire protection system plans.
- Prepare final plumbing, HVAC, fire protection, piping, and valve specifications.
- Are sufficient floor drains provided and are floor slopes sufficient?
- Has freeze protection been provided for exterior hose bibbs and other piping as necessary?
- Has heat tracing been used and clearly delineated? Is electrical connected?
- Coordinate motor control requirements with Electrical.

---

Lead Engineer Signature	Date
-------------------------	------

---

QC Reviewer Signature	Date
-----------------------	------



## Final Design and Contract Documents Checklist: Interdiscipline

- ❑ Cross-check all discipline bases.
- ❑ Coordinate structure and facility names among disciplines and with the index. Coordinate room names among the disciplines.
- ❑ Coordinate equipment tag numbers among the drawings, P&IDs, and specifications.
- ❑ Coordinate equipment locations, equipment pads, wall and slab penetrations, grating locations, and access hatches among the disciplines' drawings.
- ❑ Make sure dimensions and elevations agree among the disciplines' drawings.
- ❑ Check mechanical drawings for coordination with other disciplines, including:
  - Piping conflicts with structure
  - Access around and near equipment
  - Piping conflicts with HVAC equipment
  - Floor drain locations near equipment
  - Piping, roof drains, or HVAC ducts over electrical equipment
- ❑ Check architectural drawings for coordination with other disciplines, including:
  - Relationship of piping to doors
  - Lighting controls accessible
  - Control panels conveniently located
  - Structural cross bracing
- ❑ Check structural drawings for coordination with other disciplines, including:
  - Pipe trench location
  - Electrical conduits in/through floor and wall
- ❑ Check civil drawings for coordination with other disciplines, including:
  - Sloping sidewalk away from building entrance
  - Roof drain discharge location
  - Site lighting coordinated with yard piping
  - Walks to doors, driveways for equipment, etc.
- ❑ Coordinate locations of equipment and control panels among mechanical and electrical drawings.
- ❑ Check electrical drawings for coordination with other disciplines, including:
  - Duct bank location coordinated with piping, structures



- Interior raceway layout coordinated with structure, piping, equipment, HVAC
- Instrument location
- Instrument power requirements
- Clear definition of hazardous and corrosive areas
- Check motor horsepowers against equipment specifications
- Coordinate motor control and disconnect requirements between electrical drawings and equipment specifications
- Coordination with package system specifications regarding electrical and I&C interfaces
- Coordination with HVAC equipment and control system specifications

---

Lead Engineer Signature

Date

---

QC Reviewer Signature

Date