

**BATON ROUGE SSO PROGRAM
2002 CONSENT DECREE**



2005 ANNUAL REPORT

January 24, 2006

**BATON ROUGE SSO PROGRAM
2002 CONSENT DECREE**

2005 ANNUAL REPORT

January 24, 2006



Department of Public Works

City of Baton Rouge
Parish of East Baton Rouge

Post Office Box 1471
Baton Rouge, Louisiana
70821

January 24, 2006

CERTIFIED – RETURN RECEIPT REQUESTED

Chief,
Water Enforcement Branch (6EN-W)
Compliance Assurance and Enforcement Division
U.S. Environmental Protection Agency, Region VI
1445 Ross Avenue
Dallas, Texas 75202-2733

Re: City of Baton Rouge and Parish of East Baton Rouge
Consent Decree-Civil Action No. 01-978-B-M3
Annual Report - **Period Ending December 31, 2005**

Gentlemen:

Pursuant to Paragraph 52 of the Consent Decree, the City of Baton Rouge and Parish of East Baton Rouge hereby submits the Annual Report covering activities for the year ending December 31, 2005. This report addresses the following items:

- Remedial Measures Action Plan (RMAP)
- Treatment Facility Assessment
- Environmental Results Monitoring (ERM)
- Interim Relief Measures Activities
- Outreach and Public Awareness Program
- Plan Modification Needs
- Stipulated Penalties

These items are described in Sections XII, XIII, XIV, XVI, XV and XXI of the Consent Decree.

I certify that the information contained in or accompanying this document is true, accurate and complete. As to identified portions of this document for which I cannot personally verify their

truth and accuracy, I certify as the official having supervisory responsibility for the persons who, acting under my direct instructions, made the verification, that this is true, accurate and complete.

Sincerely,

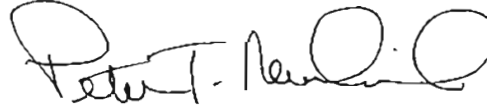
A handwritten signature in black ink, appearing to read "Peter T. Newkirk". The signature is fluid and cursive, with the first name "Peter" and last name "Newkirk" clearly distinguishable.

Peter T. Newkirk
Director of Public Works

Cc: Honorable Melvin L. "Kip" Holden, Mayor-President
Mr. Walter Monsour, Chief Administrative Officer
Mr. Bruce Hammatt, LDEQ
Chief, Environmental Enforcement Section, US DOJ
Mr. Carlos Zequeira, (6RC-EA)
Ms. Vivian Hare, (6EN-WC)
Ms. Peggy Hatch, LDEQ
Mr. Mark LeBlanc
Mr. Jim Thompson
Mr. Bryan Harmon
Mr. Richard Wright
Mr. Walter Jenkins
Mr. David Ratcliff

Table of Contents

	Page
I Remedial Measures Action Plan (RMAP)	1
II Treatment Facility Assessment.....	6
III Environmental Results Monitoring (ERM).....	7
IV Interim Relief Measures Activities	9
V Outreach and Public Awareness Program	10
VI Plan Modification Needs	11
VII Stipulated Penalties.....	12

APPENDIX A – Request for Modification to Consent Decree (Dated August 1, 2005)

APPENDIX B – Municipal Water Pollution Prevention (MWPP) Environmental Audit Report

APPENDIX C – Contract Installing New Conveyor

APPENDIX D – Outreach and Awareness Program Documentation

LIST OF TABLES

Table Number	Title	Page
1	First RMAP Project Status (original)	2
2	Second RMAP Project Status (original)	3-4
3	First RMAP Project Status (revised 12/03)	4
4	Second RMAP Project Status (revised 12/03)	5-6
5	Infiltration & Inflow Reduction Activities	6
6	Monthly Average BOD/TSS Percent Removal	8
7	Summary of Stipulated Penalties for Submittal/Construction Milestones	10
8	Summary of Stipulated Penalties for Non-Compliance Items	11

Baton Rouge Consent Decree 2005 Annual Report

This Annual Report covering the period from January 1, 2005 to December 31, 2005 is submitted in accordance with Paragraph 52 of the Consent Decree. The report addresses all items identified in Consent Decree Exhibit I regarding the Annual Report format and content.

I Remedial Measures Action Plan (RMAP)

The City/Parish identified a comprehensive remedial action plan for the collection system during consent decree negotiations, identified as Alternative 1 (the original SSO Plan) in the Consent Decree. Shortly thereafter, a VE study was commissioned to explore cost-saving alternatives, and the VE study identified seven options of the original SSO Plan for further considerations. Three of those options (3, 4 and 7) were considered equivalent low-cost options. Through a series of Metro Council and public meetings, Option 7, the Composite Plan, was selected.

The First RMAP, submitted on January 10, 2001, consists of the projects common to the three lowest cost VE options. Table 1 lists the projects in the First RMAP and identifies the status of each project based on the original schedule. The Second RMAP, submitted on November 19, 2002, consists of the projects required to complete the selected overall remedial action plan, Option 7. Table 2 lists the projects in the Second RMAP and identifies the status of each project based on the original schedule. As the planning and design activities for the RMAPs have progressed, it was apparent that modifications to the projects and schedule were necessary. On December 3, 2004, proposed RMAP modifications were submitted for review and approval in the form of Table 3 and Table 4.

Predicting a proposed budget over run has mandated, that the City/Parish reconsider the Option 7 selection, of the original SSO Plan. A written request with proposed Second RMAP modifications for review and approval were submitted on July 29, 2005, as shown in Appendix A. The City/Parish conducted a telephone conference with EPA and LDEQ on August 1, 2005 for a program status presentation. That presentation included the requested revision to the Second Remedial Action Plan (RMAP2). The requested modification represents a material change in the currently approved Second Remedial Action Plan; however, the requested revision to the RMAP2 will not extend the final compliance date beyond the existing January 1, 2015 deadline.

The Consent Decree RMAP milestone dates are as follows:

	<u>Consent Decree Date</u>	<u>Actual Date</u>
Start construction of 1 st RMAP remedial measures	January 15, 2001	January 10, 2001
Submit 2 nd RMAP schedule	December 1, 2002	November 20, 2002
Complete construction of 1 st RMAP remedial measures	May 4, 2007	
Complete construction of 33% of total RMAP	July 1, 2007	
Complete construction of 66% of total RMAP	July 1, 2011	
Complete construction of 100% of the total RMAP	January 1, 2015	

Table 2
Second RMAP Project Status (original)

Project Description	Design Status	Construction				Percent Complete
		Start Date		Completion Date		
		Sched.	Actual	Sched.	Actual	
BFU1 Ballasted Flocculation Unit for N-08	0%	03/02/04		06/15/05		
BFU2 Ballasted Flocculation Unit for N-03	0%	04/12/05		01/27/07		
BFU3 Ballasted Flocculation Unit for C-02	0%	03/25/08		01/09/10		
BFU4 Ballasted Flocculation Unit for SWWTP	0%	03/01/05		06/14/06		
N-03 North Park Area Upgrades	0%	04/12/05		01/27/07		
N-08 PS 45 Area Upgrades	0%	01/16/04		04/30/05		
C-01 PS 59 Area Upgrades	0%	03/27/07		01/10/09		
C-02 PS 23/PS 60 Area Upgrades	0%	03/25/08		01/09/10		
C-04 PS 4 Area Upgrades	0%	01/14/11		04/28/12		
C-05 PS 5 Area Upgrades	0%	12/23/09		01/06/11		
C-06 PS 15/PS 48 Area Upgrades	0%	01/16/12		04/30/13		
C-07 PS 1 Area Upgrades	0%	01/13/09		04/28/10		
S-01A PS 58 Area Upgrades	0%	01/15/08		04/29/09		
S-02 East Highland Road Area Upgrades	0%	01/13/09		04/28/10		
S-03 PS 58 Area Upgrades #1 ⁴	0%	12/23/09		01/06/11		
S-04 PS 66 Area Upgrades	0%	12/22/10		01/05/12		
S-05 PS 58 Area Upgrades #2 ⁴	0%	01/16/12		04/30/13		
S-06 PS 31 Area Upgrades	0%	01/15/10		04/30/11		
S-07 PS 944 Area Upgrades	0%	12/20/07		01/02/09		
S-09 Gardere/GSRI Area Upgrades	0%	12/20/07		01/02/09		
S-10 Tiger Bend/Antioch Area Upgrades	0%	01/17/11		05/01/12		
S-12 PS 177 Area Upgrades	0%	12/19/08		01/02/10		
S-13 PS 170/PS274 Area Upgrades	0%	12/19/08		01/02/10		
S-15 Hoo Shoo Too & Jefferson Hwy Area Upgrades	0%	12/20/07		01/02/09		
S-17 South Siegen Area Upgrades	0%	01/15/08		04/29/09		
S-18 PS 40 Area Upgrades	0%	01/15/08		04/29/09		
S-19 PS 53 Area Upgrades ⁴	0%	01/14/09		04/29/10		
S-20 PS 56 Area Upgrades ⁴	0%	01/13/09		04/28/10		
S-21 BPS 100 Area Upgrades	0%	01/16/12		04/30/13		
S-22 BPS 508 Area Upgrades	0%	01/15/13		04/30/14		
S-23 PS 120 Area Upgrades ⁴	0%	01/14/11		04/28/12		
S-24 PS 50 Area Upgrades #2 ⁴	0%	01/14/11		04/28/12		
S-25 PS 236 Area Upgrades	0%	01/15/10		04/30/11		
T-01 SWWTP Tunnel Pump Station	5%	05/10/04		08/17/06		
T-02 CWWTP Tunnel Pump Station	5%	05/10/04		02/16/06		
T-03 Tunnel - CWWTP to PS 2	5%	11/10/04		08/09/06		
T-04 Tunnel - SWWTP to Highland	5%	11/11/04		11/16/06		
T-05 Bluebonnet Tunnel Highland - South of I-10	0%	05/10/05		11/27/07		
T-06 Brightside/Perkins/Ben Hur Tunnel	0%	05/09/07		07/22/09		
T-07 Southeast Baton Rouge Minor Tunnels	0%	11/10/06		02/18/10		

Table 2 (continued)
Second RMAP Project Status (original)

Project Description	Design Status	Construction				Percent Complete
		Start Date		Completion Date		
		Sched.	Actual	Sched.	Actual	
T-08 Old Hammond Highway Minor Tunnels ^{1,3}	0%	05/11/09		06/20/11		
T-09 Tunnels South of Old Hammond to Bluebonnet ^{1,3}	0%	05/10/05		12/30/08		
T-10 Tunnels North of PS 2, Central Service Area ^{1,3}	0%	02/08/08		05/20/11		
T-11 Perkins Road Tunnel, Pecue to Bluebonnet ^{1,3}	0%	11/09/05		03/19/08		
T-12 Highland Road Tunnel West of Gardere ^{1,3}	0%	05/10/05		02/19/08		
T-13 Pecue Lane Tunnel ^{1,3}	0%	05/09/06		10/21/08		
T-14 Sherwood Forest Boulevard Tunnel ^{1,3}	0%	08/11/08		03/08/11		
T-15 Tunnels South of PS 2 in Central Area ^{1,3}	0%	05/09/07		04/08/09		
T-16 Tunnel Tie-ins (Phases 1, 2, & 3) ^{1,3}	0%	05/26/08		02/21/13		
T-17 Highland Road East Tunnels ^{1,3}	0%	11/09/05		12/30/09		
T-18 Pump Station Demolition (Phases 1 & 2) ^{1,3}	0%	03/26/12		07/16/14		

¹ Project deleted

² Project separated into smaller scopes/projects (Project number & description may be changed or re-used)

³ Project combined with others (Project number & description may be changed or re-used)

⁴ Project description may have changed

⁵ New Project

Table 3
First RMAP Project Status (proposed revision)

Project Description	Design Status	Construction				Percent Complete
		Start Date		Completion Date		
		Sched.	Actual	Sched.	Actual	
N-02 PS 49/52 Area Upgrades	100%	04/16/04	05/24/04	04/12/05		77%
N-05 PS 24 Area Upgrades	100%	04/12/04	05/17/04	04/14/05		79%
N-09 PS 44/46 Area Upgrades	100%	02/09/04	12/01/03	05/27/05		89%
N-10 PS 240 Area Upgrades	100%	05/24/04	08/30/04	05/26/05	10/31/05	100%
N-11 PS 65 Area Upgrades	50%	03/28/05		03/30/06		
N-12 North Area Lateral Rehabilitation	50%	09/17/04		03/15/06		
N-14 Bellingrath Rehabilitation	100%	12/09/03	12/09/03	12/07/04	12/30/04	100%
N-15 Frenchtown Road Rehabilitation	100%	04/23/04	05/24/04	04/25/05	07/08/05	100%
N-23 North Area Comp. Rehabilitation	100%	08/10/04	08/30/04	08/09/05		78%
N-31 PS 45 Area Rehabilitation	100%	05/09/00	05/09/00	01/23/01	01/23/01	100%
N-99 Further Investigations (North Area)	100%	N/A	N/A	N/A	N/A	N/A
C-03 PS 2 Area Rehabilitation	100%	11/21/01	03/04/02	02/28/03	09/28/02	100%
S-01B SWWTP-Influent Pump Station	100%	10/16/00	01/10/01	08/02/02	04/14/03	100%
S-08 Industriplex Area Upgrades	95%	06/16/04		12/11/05		
S-11 PS 40 Area Upgrades	100%	11/12/01	08/06/03	02/28/03	12/22/03	100%
S-14 Kleinpeter Area Upgrades	95%	03/15/05		12/14/05		
S-16 PS 136 Area Upgrades	95%	05/20/04		11/14/05		
S-99 Further Investigations (South Area)	100%	10/01/01	07/5/02	09/26/03	05/22/03	100%

Table 4
Second RMAP Project Status (proposed revision)

Project Description	Design Status	Construction				Percent Complete
		Start Date		Completion Date		
		Sched.	Actual	Sched.	Actual	
NBFU Ballasted Flocculation Unit for N-08	0%	07/24/05		07/24/08		
CBFU Ballasted Flocculation Unit for C-02	0%	05/30/07		12/03/08		
SBFU Ballasted Flocculation Unit for SWWTP	0%	12/17/05		12/22/07		
N-01 Choctaw Area Pump Station	0%	12/07/05		06/04/07		
N-03 North Park Area Upgrades	0%	08/27/06		11/04/08		
N-04 PS 47 Area Upgrades	0%	06/09/07		06/09/08		
N-07 PS 39/55 Area Upgrades	5%	03/05/06		03/05/07		
N-08 PS 45 Area Upgrades	0%	05/11/07		11/04/08		
N-13 North Choctaw Area Upgrades	0%	08/22/05		08/27/07		
N-16 Annual Rehabilitation Contract #1	100%	01/19/04	01/19/04	12/30/06		66%
N-17 Annual Rehabilitation Contract #2	100%	07/10/04	07/16/04	12/31/07		33%
N-18 Annual Rehabilitation Contract #3	100%	10/09/04	09/27/04	12/31/07		33%
N-19 Annual Rehabilitation Contract #4	100%	01/03/05	01/26/05	12/31/07		33%
N-20 North Area Influent Forcemain	0%	08/02/06		08/06/08		
N-21 North Area Influent Pump Station	0%	02/10/07		08/06/08		
C-01 PS 59 Area Upgrades	0%	08/01/07		02/05/09		
C-02 PS 23/PS 60 Area Upgrades	0%	11/29/07		06/05/09		
C-04 PS 4 Area Upgrades	0%	06/28/11		06/26/12		
C-05 PS 5 Area Upgrades	0%	06/29/10		03/31/11		
C-06 PS 15/PS 48 Area Upgrades	0%	06/26/12		06/25/13		
C-07 PS 1 Area Upgrades	0%	06/30/09		07/02/10		
S-01A PS 58 Area Upgrades #1	0%	01/24/08		01/25/09		
S-02 East Highland Road Area Upgrades	0%	11/25/08		11/27/09		
S-03 PS 58 Area Upgrades #2	0%	06/01/10		06/02/11		
S-04 PS 66 Area Upgrades	0%	11/30/10		11/30/11		
S-05 South Choctaw Area Upgrades #2	0%	11/15/05		11/20/07		
S-06 PS 31 Area Upgrades	0%	12/01/09		12/03/10		
S-07 PS 944 Area Upgrades	0%	05/27/08		05/29/09		
S-09 Gardere/GSRI Area Upgrades	0%	05/27/08		05/29/09		
S-10 Tiger Bend/Antioch Area Upgrades	0%	05/31/11		05/29/12		
S-12 PS 177 Area Upgrades	0%	05/26/09		05/28/10		
S-13 PS 170/PS274 Area Upgrades	0%	05/26/09		05/28/10		
S-15 Hoo Shoo Too & Jefferson Hwy Area Upgrades	0%	03/24/09		12/23/09		
S-17 South Siegen Area Upgrades	0%	04/01/08		04/03/09		
S-18 PS 40 Area Upgrades	0%	05/27/08		05/29/09		
S-19 PS 53 Area Upgrades	0%	05/26/09		05/28/10		
S-20 PS 56 Area Upgrades	0%	05/26/09		05/28/10		
S-21 BPS 100 Area Upgrades	0%	03/27/12		03/26/16		
S-22 BPS 508 Area Upgrades	0%	09/11/12		09/10/12		
S-23 PS 120 Area Upgrades	0%	05/31/11		05/29/12		
S-24 PS 50 Area Upgrades #2	0%	05/29/07		05/30/08		
S-25 PS 236 Area Upgrades	0%	05/18/10		11/10/11		
T-01 SWWTP Tunnel Pump Station	5%	05/18/05		05/13/07		

Table 4 (continued)
Second RMAP Project Status (proposed revision)

Project Description	Design Status	Construction				Percent Complete
		Start Date		Completion Date		
		Sched.	Actual	Sched.	Actual	
T-02 CWWTP Tunnel Pump Station	5%	05/18/05		08/14/06		
T-03 Central Service Area Trunk Tunnels	5%	06/22/05		01/11/10		
T-04 South Service Area Trunk Tunnels	5%	06/23/05		12/30/10		
T-05 Bluebonnet/Airline Tunnels	0%	10/26/06		03/26/11		
T-06 Airline Extension Tunnels	0%	12/12/07		12/12/10		
T-07 Old Hammond Tunnels	0%	06/12/07		06/20/12		

In accordance with Paragraph 35 of the Consent Decree, the City/Parish shall spend at least \$3 million per year for sewer repairs, sewer rehabilitation, and other capital needs related to reduction of Infiltration and Inflow ("I & P") into the North, Central, and South Plant Collection Systems. The following table identifies the funds expended during 2005 to meet this requirement.

Table 5
Infiltration & Inflow Reduction Activities

PROJECT	DESCRIPTION	2005 % COMPLET	ACTUAL % COMPLETE	CONSTRUCTION COST/BID	EXPENDITURES 2005
05-CDR-RBL2	Annual Lining Project (Yr. 1)	100%	100%	\$1,000,000.00	\$914,267.00
02-CDR-02	Annual Point Repair Project (Yr. 3)	100%	100%	\$1,500,000.00	\$813,577.12
03-CDR-06	Annual Manhole Rehab. Project (Yr. 2)	100%	100%	\$769,540.00	\$452,143.00
04-CDR-01	Annual Parishwide Point Repair Project (Yr. 2)	100%	100%	\$1,000,000.00	\$932,483.70
05-CDR-PI	Physical Inspection for Evaluation of Portions of the Existing Sanitary Sewers	100%	100%	\$1,000,000.00	\$952,776.86
TOTAL EXPENDITURES IN 2005				\$5,269,540.00	\$4,065,247.68

II Treatment Facility Assessment

The Treatment Facility Assessment was submitted March 26, 2002. In the Treatment Facility Assessment, all process units and conveyance elements were determined to have capacity for current and projected design flows at all three WWTPs. Also, all WWTPs have the ability to meet their permit effluent limits. Based on these findings, no WWTP facility improvements or expansion are required. The Treatment Facility Assessment also indicated that the monthly Operators Process Control meetings currently led by Dr. John J. Sansalone of LSU are having a beneficial impact on plant performance.

The City/Parish submitted a Municipal Water Pollution Prevention (MWPP) Environmental Audit Reports on May 25, 2005, August 4, 2005 and October 25, 2005 (see Appendix B). This report contains an evaluation and rating for influent loadings, plant performance, overflows & bypasses, treatment plant age, sludge disposal, new development in collection system, and operator certification training for the North, South and Central Wastewater Treatment Plants. The MWPP audit rated the treatment plants on the above factors for the year following the entry into the Consent Decree. The actions that will be taken to maintain compliance and prevent effluent violations are presented in a MWPP Resolution, which was submitted along with the audit. Some of those actions include implementation of aggressive process control strategies recommended by Louisiana State University Civil & Environmental Engineering Department and managing a project to reduce the high concentration of hydrogen sulfide at the treatment plants.

III Environmental Results Monitoring (ERM)

The objective of the ERM program is to measure the environmental impacts of the SSO Program by monitoring sewage indicating pollutants in major receiving waters prior to and following completion of remedial measures within each drainage basin. The four sampling locations, identified in Figure 1, include all major tributaries in East Baton Rouge Parish, which enter the Amite River System – and eventually Lake Ponchartrain.

The Phase I Baseline Monitoring was completed during the 2004 reporting period. The Phase II Results Monitoring will began 6 months following completion of all remedial measures within a specified drainage area contributing to an identified sampling location.

IV Interim Relief Measures Activities

Paragraph 39 of the Consent Decree provides interim effluent limits of 75% removal of BOD and TSS (based on 30-day average removal rates), until completion of all RMAP construction projects, as an interim relief to the 85% removal requirement of the three WWTP NPDES permits. During 2005 the North and Central WWTPs have been in compliance with the 75% interim effluent limits for removal of TSS eleven months out of twelve months. In fact, the Central WWTP met the permit limit of 85% removal of TSS and 75% interim effluent limits for removal of BOD the entire year, as illustrated by Table 6.

The South WWTP has been in compliance with the 75% interim effluent limit for TSS all year. However, it did not meet the 75% interim effluent limit for BOD for 8 months of the year. The South WWTP is experiencing operational difficulties related to trickling filters, chlorine inductor, primary basin #1 & #2, and bar screens E101, E102, & E103 being out of service.

Replacing the distributors at the four South WWTP trickling filters was completed in the fourth quarter of 2005. The chlorine inductor was also refurbished in the fourth quarter of 2005 and is now in service. Bar screens will be available once the new conveyor is installed. The contract installing the new conveyor started construction on May 9, 2005 and is scheduled for completion in February 2006 as documented in Appendix C.

Table 6
Monthly Average Percent Removal

	Jan.	Feb.	Mar.	April	May	June	July	Aug.	Sept.	Oct.	Nov.	Dec.
North Plant- LA0036439												
BOD	73	70	73	77	77	81	85	85	84	80	79	78
TSS	74	75	76	82	85	86	91	91	92	88	85	80
Central Plant- LA0036421												
BOD	80	78	82	86	88	85	83	87	87	87	83	80
TSS	88	88	89	91	93	92	93	90	93	92	93	90
South Plant- LA0036412												
BOD	68	63	64	69	72	70	72	75	74	76	77	76
TSS	79	80	79	84	85	84	83	86	87	86	86	88

V Outreach and Public Awareness Program

During this reporting period, the City/Parish has continued its Outreach and Public Awareness Program in the same format and methods as used in past reporting periods. During the City/Parish budgeting process this year, the Mayor-President presented information about the Sanitary Sewer Overflow Program (SSO) and the Consent Decree. As of September 30, 2005, the City/Parish has appropriated \$667.2 million for sewer capital improvements. Of this amount, \$166.8 million will fund the first phases of the SSO Capital Improvements Program.

During this reporting period, the City/Parish has continued a series of workshops/seminars in the same format and methods as used in past reporting periods.

During this reporting period City/Parish continued its Sewer Tie-in Program, which enables the homeowner to abandon their old septic tank at a fixed price. The City/Parish, through negotiations with several plumbing contractors, developed an agreement between the homeowners and contractors to wave all City/Parish permit fees in order to keep the septic tank abandonment fees to a minimum. In order to assist low income homeowners, the City/Parish, with funding from of a Community Development Block Grant (CDBG), pays for the septic tank abandonment fees after the homeowner has met the program guidelines (see Appendix D). The information handed out at the public meeting (see attachment) was placed on the program website for public access. The information presented in this section demonstrates that the City/Parish has been in compliance with Section XV Outreach and Public Awareness Program during the reporting period.

Activity

Date / Status

- | | |
|--|------------------|
| 1. Provide Program informational brochures on SSO Plan | July 2001 |
| 2. Neighborhood meetings in various Metropolitan Council Districts | On going |
| 3. Meet with Mayor and the Metropolitan Council members on program | On going |

	status	
4.	Develop information program on the Consent Decree and the Sewer Improvement Program	On going
5.	Post Consent Decree and overflow information on City-Parish website	June 2002
6.	Public appearances by DPW Director	On going
7.	Provide SCIP and SSO CAP information in the Mayor-President's Budget Message	Nov 2004
8.	Sewer Tie-In Program	On going
9.	Provide fact sheet about the SEPs on City-Parish website	Dec 2002
10.	Consent Decree copies made available	ongoing
11.	SRF Loan Program	On going

VI Plan Modification Needs

The City/Parish has not identified any deficiencies in the Cross Connection Elimination Plan or the Preventive Maintenance Program. However the Remedial Measures Action Plan (RMAP) was revised and submitted for approval on July 29, 2005. The Remedial Measures Action Plan was revised to provide for revisions to the Second RMAP (RMAP2). Due to budgetary constraints encountered in the selection of option 7, the City/Parish has revised the RMAP2 to implement a much more aggressive and comprehensive sewer rehabilitation program to reduce inflow and infiltration. These changes will not affect the final Consent Decree RMAP complete construction date of January 1, 2015.

VII Stipulated Penalties

Table 7 presents a summary of submittal and construction milestone dates subject to stipulated penalties in accordance with Section XXI of the consent decree. As of December 31, 2005 the City/Parish has not missed any submittal or construction milestone deadlines, and therefore is not subject to any stipulated penalties due to milestone dates.

Non-compliance items, which are subject to stipulated penalties in accordance with Section XXI of the consent decree, are identified in each consent decree quarterly report. A summary of non-compliance items and associated stipulated penalties reported in quarterly reports for the year 2005 are presented in Table 8.

Table 7
Summary of Stipulated Penalties for Submittal/Construction Milestones

Stipulated Penalties		Deadline	Completion	Total Owed*	Total Paid*
Past Stipulated Penalties		15-Apr-02	12-Apr-02	\$216,000	\$216,000
Failure to Submit Timely Reports					
Quarterly Reports	11 th Report	31-Jan-05	24-Jan-05		
	12 th Report	30-Apr-05	11-Apr-05		
	13 th Report	31-July-05	156-July-05		
	14 th Report	31-Oct-05	21-Oct-05		
Annual Reports	2005 Report	31-Jan-06	27-Jan-06		
Collection System PMP Plan		30-Mar-01	29-Mar-01		
Treatment Facility Assessment Report		30-Mar-02	26-Mar-02		
SEP Completion Report		15-Sep-04	10-Sep-04		
Failure to Submit Timely and Complete 2nd RMAP		1-Dec-02	20-Nov-02		
Failure to Meet RMAP and Construction Milestones					
Start of Construction		15-Jan-01	10-Jan-01		
1st RMAP Construction Complete		4-May-07			
1st & 2nd RMAP at 33%		1-July -07			
1st & 2nd RMAP at 66%		1-July -11			
2nd RMAP Design Completion		3-June-13			
Completion of all Construction		1-Jan-15			
Failure to Meet SEP Milestone Dates					
Donwood/Oak Manor Project	(start construction)	14-Mar-03	21-Feb-03		
	(end construction)	14-Mar-04	04-Sept-03		
Pleasant Hills/Green Acres Project	(start construction)	14-Jun-03	27-Jun-03		
	(end construction)	14-Jun-04	30-Jul-04		
Sharon Hills/Cedar Glen/Pleasant Hills Project	(start construction)	14-Mar-03	27-Jun-03		
	(end construction)	14-Aug-04	30-Jul-04		
Stumberg Lane Project	(start construction)	14-Mar-03	28-Mar-03		
	(end construction)	14-Mar-04	15-Sept-03		
Total				\$216,000	\$216,000

Table 8
Summary of Stipulated Penalties for Non-Compliance Items

Stipulated Penalties	# of Occurrences	Per Occurrence	Total
Failure to Seal/Eliminate New Cross Connections			
Unauthorized Discharges			
Less Than 1 million gallons and Non-Compliance		\$5,000	
Less Than 1 million gallons and Compliance (Post-remedial)	N/A	N/A	
1 million gallons or more	1	\$5,000	\$5,000
Non-compliant Discharges			
Daily Maximum Limits			
Weekly Average Limits	18	\$1,000	\$18,000
Monthly (30-day Average) Limits	36	\$2,500	\$90,000
Total			\$113,000

Appendix A



Office of the Mayor-President

City of Baton Rouge
Parish of East Baton Rouge
222 St. Louis Street
Post Office Box 1471
Baton Rouge, Louisiana 70821
225/389-3100
Fax 225/389-5203

MELVIN L. "KIP" HOLDEN
Mayor-President

July 29, 2005

Michael Michaud, Chief
Water Enforcement Branch (6EN-W)
Compliance Assurance and Enforcement Division
U.S. Environmental Protection Agency - Region 6
1445 Ross Avenue Suite 1200
Dallas, TX 75202-2733

Harold Leggett, Assistant Secretary
Office of Environmental Compliance
Department of Environmental Quality
P.O. Box 4312
Baton Rouge, LA 70821-4312

Re: Baton Rouge City/Parish Consent Decree
Civil Action No. 01-978-B-M3
Request for Modification to Consent Decree
Agency Interest Nos. [AI#4841, AI#4842, AI#4843]

Attention: Mona Tate

Dear Mr. Michaud, Ms. Tate and Mr. Leggett:

The City of Baton Rouge/Parish of East Baton Rouge ("City/Parish") hereby requests a modification to the 2001 Consent Decree pursuant to the procedures of Section XXXIV of the Consent Decree. The requested modification represents a material change in the currently approved Second Remedial Action Plan (RMAP2); however, the requested revision to the RMAP2 will not extend the final compliance date beyond the existing January 1, 2015 deadline. The City/Parish believes that the modification proposed herein will achieve the purposes of the Consent Decree in a more permanent, reliable, and less risky manner than the current Second RMAP. The primary features of the Revised Second RMAP are:

- Implementation of a much more aggressive and comprehensive sewer rehabilitation program to reduce inflow and infiltration

- Elimination of the deep tunnels (as the need will be eliminated by comprehensive inflow and infiltration control and other system upgrades)
- Revision to the pipe and pump station upgrades (although portions of this will parallel efforts already in the existing Second RMAP);
- Improvements to the South WWTP consisting of a new head works, new influent pump station, flow equalization, conversion to an activated sludge process and elimination of chlorine currently used for disinfection and installation of UV disinfection.

The specific proposed modifications to both the existing Consent Decree and to the Second RMAP are attached.

The City/Parish commissioned Camp Dresser & McKee Inc. (“CDM”) to conduct a formal reassessment of the Consent Decree compliance program. A copy of the CDM Report is attached in support of this modification request. This evaluation concludes that the City/Parish should shift its primary emphasis away from the current plan which relies primarily on conveyance and storage through the use of a tunnel system. The newly proposed plan emphasizes comprehensive sewer system rehabilitation and infiltration and inflow (I/I) reduction combined with focused facility improvements as needed to increase wet-weather pumping and treatment capacity.

A comprehensive rehabilitation approach has been demonstrated in other programs as the best means of accomplishing substantial I/I reduction during both wet weather and dry weather because it eliminates the vast majority of I/I sources, including those on private property when needed. A comprehensive approach has been shown to remove between 50 and 85 percent of I/I peaks and volume. Based on the CDM evaluation, application of this comprehensive approach in priority areas of the City/Parish system will have substantial benefits in terms of I/I reduction and improved local system performance. The City/Parish rehabilitation program will include a comprehensive sewer system evaluation survey (SSES) in areas selected as those offering the best opportunity to reduce I/I and control sanitary sewer overflows (SSOs) based on flow monitoring information, capacity modeling, and historical operations and maintenance records. Within the priority areas, comprehensive rehabilitation will include the lining or repair of pipe, manholes, and service laterals that do not meet I/I control standards. The rehabilitation strategy will be closely coordinated with other needed facility improvements to achieve results as quickly as possible in priority areas with a history of chronic, repeated SSOs.

We believe that this increased focus on infrastructure rehabilitation will provide us with many benefits in terms of I/I reduction as well as reduced system operations and maintenance costs and improved structural integrity. This proposal will result in “fixing” the system to prevent

overflows rather than constructing tunnels to store and transport the excess wastewater generated from an overly leaky system.

From our current analysis, the proposed alternative plan will cost approximately \$500 million, which includes approximately \$200 million of sewer rehabilitation, approximately \$232 million in pump station, force main upgrades, and other gravity sewer system projects, and approximately \$68 million in treatment plant improvements, in addition to the approximately \$63 million in improvements that have already been completed or begun by the City/Parish. The details of the proposed modifications may be found in the attachments provided with this letter.

One area of proposed modification associated with the wastewater improvements at the South wastewater treatment plant (WWTP) is the need for temporary interim limits to facilitate the conversion of the plant to an Activated Sludge Process. In addition to the interim limits for the South WWTP already contained in the current Consent Decree, we are hereby requesting additional interim limits of 45 mg/l of BOD₅ and 45 mg/l of TSS as monthly average limits for the South WWTP and 60 mg/l of BOD₅ and TSS as weekly average limits. The proposed Revised Second RMAP improvement plan not only focuses on the elimination of SSOs, but also on achieving NPDES/LPDES Permit compliance at all three wastewater treatment plants. The charts below show the BOD₅ and TSS effluent concentrations at the North, Central and South WWTPs for the years 2003 through May of 2005:

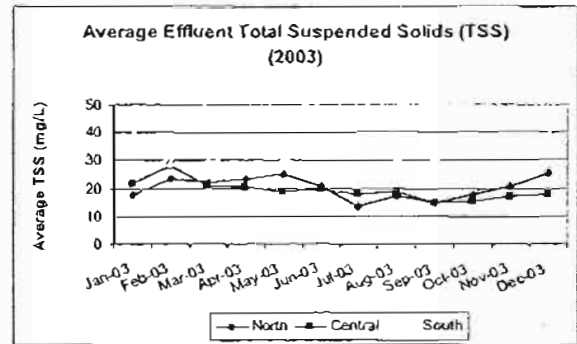
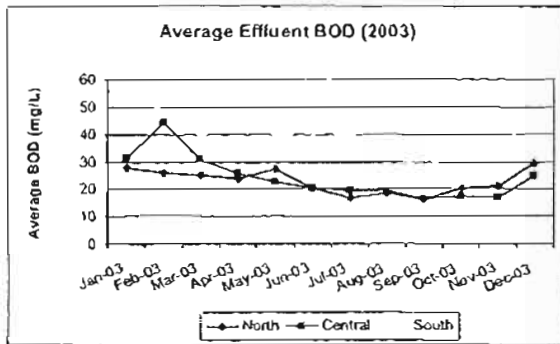

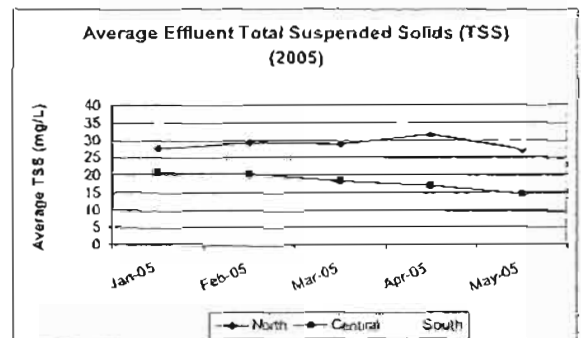
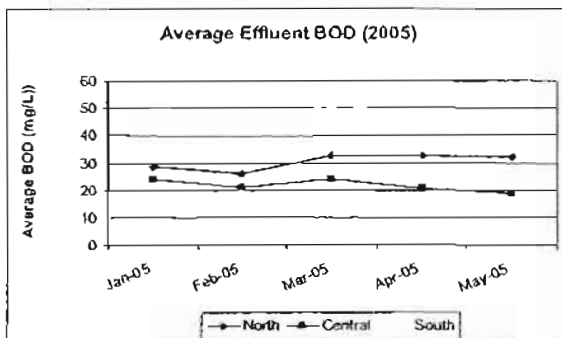
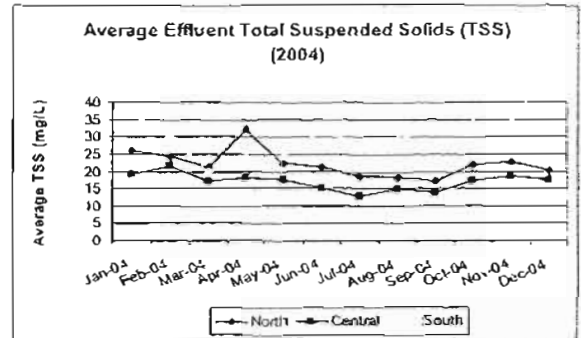
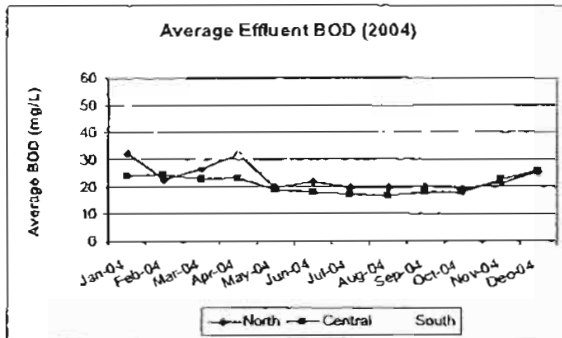

As seen, the North and Central WWTPs show a trend toward compliance and, with the exception of few minor exceedances, those plants are operating satisfactorily. It is projected that these plants will be able to remain in compliance after the implementation of the remedial measures in the proposed Revised Second RMAP as well. However, as is evident from the charts above, the South WWTP is struggling to maintain compliance with the monthly average BOD₅ and TSS limits. Although there have been fewer issues with the weekly average limits (as noted on quarterly reports), during conversion of the plant the weekly limits for BOD₅ and TSS will be difficult to meet. The draft plan and schedule allows design and subsequent construction on the improvements to the South WWTP to begin immediately. With the comprehensive sewer system upgrades proposed, the peak flows to the South WWTP will increase as system deficiencies are currently precluding all flows from reaching the plant. Flows to the North and Central WWTPs are projected to remain within the design capacities of these plants with minor system operational improvements.

The proposed plan entails upgrading the South WWTP to an activated sludge facility and abandoning the trickling filters. Also, this new plan covers upgrading the total treatment capacity from 125 mgd to 200 mgd. Construction of an activated sludge process has numerous advantages including: 1) effluent quality is better than 30 mg/l of BOD₅ and TSS; 2) improves

ability to consistently meet NPDES/LPDES permit limits; 3) enables elimination of primary effluent pump stations; 4) enables abandonment of chlorination facilities for disinfection and allows use of ultraviolet light (UV) for disinfection; 5) helps to control odors; 6) helps with aesthetic concerns in fast developing section of town; 7) eliminates current problems with snails; and 8) allows smoother delivery of flow to plant.

Interim limits are requested because the process of upgrading the plant requires abandoning half of the existing trickling filter plant during construction. The City/Parish will do everything within its means to expedite this part of the work. Taking into consideration the limitation imposed on us by Public Bid Laws and our limited control over the construction contractor, we respectfully request that the Environmental Protection Agency (EPA) and the Louisiana Department of Environmental Quality (LDEQ) allow the interim limits proposed above to be in place for the time period commencing on the date of entry of a Modified Consent Decree through the date 30 days following completion of shakedown of the new activated sludge facility.

We are appreciative of the close cooperation we have received from both the EPA and LDEQ in allowing us the time and opportunity to conduct this reevaluation and to prepare this alternative proposal. We are hopeful that both agencies will be able to review and approve this request well before the 120 day deadline provided in Section XXXIV. We will make available all personnel who may be needed to respond to any questions you may have concerning this proposal. As you know, we currently have a meeting scheduled in Dallas on September 1, 2005 to review the proposal. If you have any questions or comments prior to that time, please direct them to Mr. William Daniel and we will respond as quickly as possible. Thank you again for your consideration.

Sincerely,

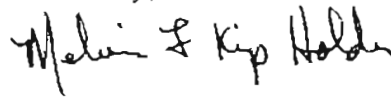
A handwritten signature in black ink that reads "Melvin L. Kip Holden". The signature is written in a cursive, slightly slanted style.

Melvin L. "Kip" Holden
Mayor-President

MLH/sb
attachments

cc: Mr. Walter Monsour, Chief Administrative Officer
Mr. William B. Daniel, IV, Interim Director of Public Works
Mr. Jim Thompson
Ms. Irys Allgood
Mr. Jeff Broussard
Mr. Bryan Harmon
Mr. Mark LeBlanc
Mr. Charles Faultry (EPA Region 6)
Ms. Vivian Hare (EPA Region 6)
Mr. Carlos Zequeira (EPA Region 6)
Ms. Gloria Vaughn (EPA Region 6)
Mr. Harold Leggett (LDEQ)
Ms. Peggy Hatch (LDEQ)
Mr. Ted Broyles (LDEQ)
Mr. Michael Donnellan (DOJ)
Mr. Justin Haydel (CDM)

Contents

Executive Summary:

ES.1	History and Background.....	ES-1
ES.2	Analysis of Existing System	ES-2
ES.2.1	Wastewater Treatment.....	ES-2
ES.2.2	Collection and Conveyance Systems	ES-2
ES.3	Model Analysis and Verification	ES-2
ES.4	Proposed Solution.....	ES-3
ES.4.1	Category 1: Comprehensive Sewer Rehabilitation and Pump Station Upgrades.....	ES-3
ES.4.2	Category 2: Transmission and Conveyance System Improvements.....	ES-4
ES.4.3	Wastewater Treatment and Flow Equalization.....	ES-5
ES.5	Construction Sequence and Schedule	ES-6
ES.6	Program Costs	ES-6
ES.6.1	Category 1: Comprehensive Sewer Basin Rehabilitation and Pump Station Upgrades	ES-7
ES.6.2	Category 2: Pump Station and Transmission/Conveyance System Improvements.....	ES-7
ES.6.3	Category 3: Flow Equalization and Wastewater Treatment Improvements.....	ES-7
ES.7	Operation and Maintenance.....	ES-8
ES.7.1	Collection System O&M Costs.....	ES-8
ES.7.2	Pumping O&M Costs.....	ES-8
ES.7.3	Wastewater Treatment Plant O&M Costs.....	ES-8
ES.7.4	Total O&M Savings.....	ES-9

Section 1: Introduction

1.1	Project History.....	1-1
1.2	Purpose and Objective	1-1
1.3	Project Approach.....	1-2
1.4	Report Structure.....	1-4

Section 2: System Description and Data

2.1	Wastewater Treatment.....	2-1
2.2	Collection System.....	2-2
2.3	Hydraulic Model.....	2-3
2.3.1	Network Data.....	2-3
2.3.2	Flow Input and Data Groups	2-4
2.4	Flow Verification.....	2-7
2.5	Model Modifications	2-7
2.6	Design Storm Considerations.....	2-8

Section 3: Existing System Assessment

3.1	System Deficiencies	3-1
3.2	Potential Solutions	3-2
3.2.1	Sewer Rehabilitation.....	3-2
3.2.2	Trunk Sewer System Improvements.....	3-11
3.2.3	Pump Station Improvements	3-13
3.2.4	Flow Equalization	3-13
3.3	Wastewater Treatment Plant Evaluation.....	3-14
3.3.1	Results of Hydraulic Modeling Related to the WWTPs.....	3-14
3.3.2	WWTP Effluent Quality.....	3-15

Section 4: Improvement Plan

4.1	Category 1: Comprehensive Sewer Basin Rehabilitation And Pump Station Upgrades	4-1
4.2	Category 2: Pump Station and Transmission/Conveyance System Improvements.....	4-2
4.3	Category 3: Flow Equalization and Wastewater Treatment Improvements	4-3

Section 5: Implementation Plan

5.1	Requirements.....	5-1
5.2	Construction Sequence and Schedule	5-1
5.2.1	Category 1: Comprehensive Sewer Basin Rehabilitation And Pump Station Improvements	5-2
5.2.2	Category 2: Pump Station and Transmission/Conveyance System Improvements.....	5-3
5.2.3	Category 3: Flow Equalization and Wastewater Treatment Improvements	5-4
5.3	Estimated Design and Construction Cost	5-5
5.3.1	Category 1: Comprehensive Sewer Basin Rehabilitation And Pump Station Upgrades	5-5
5.3.2	Category 2: Pump Station and Transmission/Conveyance System Improvements	5-6
5.3.3	Category 3: Flow Equalization and Wastewater Treatment Improvements	5-6
5.4	Operation and Maintenance (O&M)	5-7
5.4.1	Wastewater Treatment Plant O&M Costs	5-7
5.4.2	Pumping O&M Costs	5-8
5.4.3	Collection System O&M Costs	5-8
5.4.4	Total Operation and Maintenance Savings.....	5-8
5.5	Program Costs	5-9

Appendices

- Appendix A* Proposed Modified Consent Decree
- Appendix B* Revised Second Remedial Action Plan
- Appendix C* Summary of Select R-Values
- Appendix D* Private Lateral Rehabilitation Investigation Results
- Appendix E* Detailed Implementation Schedule
- Appendix F* Cost Estimate Information

List of Figures

Number	Figure Name	Following Page
2-1	Wastewater Treatment Plant Locations	2-1
2-2	Existing Sewer System	2-2
2-3	System Subcatchments	2-8
3-1	Location of Predicted System Overflows	3-1
4-1	North Service Area Category 1 Improvements	4-2
4-2	Central Service Area Category 1 Improvements	4-2
4-3	South Service Area Category 1 Improvements	4-2
4-4	North Service Area Category 2 Improvements	4-2
4-5	Central Service Area Category 2 Improvements	4-2
4-6	South Service Area Category 2 Improvements	4-2
4-7	Alternative Locations for the New South WWTP Headworks And Flow Equalization Facility	4-5
5-1	Program Implementation Schedule	5-1

List of Tables

Table 2-1:	Treatment Plant Flow Information	2-1
Table 2-2:	Summary of Gravity Sewer Pipe Length	2-2
Table 2-3:	Modeled Network Information	2-4
Table 2-4:	Rainfall Group Model Storm Event	2-6
Table 2-5:	Rainfall Volumes Computed in the Current Study	2-9
Table 3-1:	Cost Estimate for Sewer Rehabilitation	3-10
Table 3-2:	Treatment Plant Capacity and Expected Peak Flow	3-14
Table 5-1:	Projected Cash Flow Requirements	5-10

Executive Summary

ES.1 History and Background

On March 14, 2001, the City of Baton Rouge/Parish of East Baton Rouge (City/Parish) entered into a Consent Decree with the Environmental Protection Agency (EPA) and the Louisiana Department of Environmental Quality (LDEQ). The Consent Decree outlines a scheduled program of system improvements to address historical overflows and by-passes that have occurred within the collection system and violations of effluent discharge limits at the three wastewater treatment plants (WWTP). The Consent Decree provided alternatives for system correction and required completion of construction and full operation by specific dates for three of the alternatives.

Prior to December 2002 the City/Parish elected to select Alternative 7, which provided for construction of deep underground tunnels, removal of numerous pump stations by connection to the tunnel system, installation of Ballasted Flocculation for peak wet weather treatment at the treatment plants, limited sewer rehabilitation, and construction of tunnel pump stations. In 2005, representatives of the City/Parish spoke with EPA about amending the Consent Decree to include a more aggressive approach to sanitary sewer overflow (SSO) abatement – namely comprehensive sewer rehabilitation as an alternative to the deep tunnel system. EPA agreed not to impose fine-related deadlines in the current Consent Decree to allow the City/Parish 90-days (beginning May 1, 2005) to verify and develop the comprehensive sewer rehabilitation option.

The City/Parish subsequently hired Camp Dresser & McKee Inc. (CDM) to provide engineering services to evaluate the existing sewer system model and develop a plan which would address the causes of the rainfall dependent inflow and infiltration (RDII) and resulting system overflows. The result of the analysis is the development of a Revised Second Remedial Measures Action Plan (RMAP2). The proposed Revised RMAP2 identifies the combination of system improvements needed to control wet weather overflows during the simulated planning condition, sewer rehabilitation to reduce RDII, system conveyance upgrades to address capacity problems, and improvements at the South WWTP to achieve permit compliance during both wet and dry weather conditions.

The Consent Decree requires the RMAP2 to provide specific information related to system improvements to reduce overflows and comply with the requirements of the Consent Decree. Specifically, the Consent Decree states the following.

“In the Second RMAP, the City/Parish shall provide a detailed description of the selected remedial measure and shall specify a schedule for beginning and completing construction of each element of the selected remedial measure not addressed in the First RMAP. The Second RMAP shall also set forth a process for evaluating and providing the personnel and training that will be required to successfully implement the selected

remedial measure. The Second RMAP shall also provide an estimate of the cost of the selected remedial measure and a detailed description of how the City/Parish will fund the remedial measure to be implemented.”

The revised RMAP2 is provided as Appendix B to this report and is summarized in this section. Each of the required elements is addressed in this report.

ES.2 Analysis of Existing System

The City/Parish operates three wastewater treatment plants and most of the collection systems draining to these treatment plants.

ES.2.1 Wastewater Treatment

The wastewater treatment plants are permitted as secondary treatment facilities and all three plants generally includes preliminary treatment including screening and grit removal, primary clarification, biological treatment through trickling filters, secondary clarification, and disinfection through use of chlorine.

The treatment plants discharge directly into the Mississippi River or to its tributary. The discharge limits require an average monthly limit of 30 milligrams per liter (mg/l) for 5-day biochemical oxygen demand (BOD₅) and total suspended solids (TSS) and a weekly maximum average of 45 mg/l for both of these parameters. The plants have fecal coliform discharge limits of 200 colonies per 1000 milliliters (ml) average and 400 colonies per 1000 ml peak. Because the treatment plants provide disinfection by chlorination and removal of chlorine prior to discharge through the use of sulfur dioxide, the plants also have specific total chlorine residual (TRC) limitations, which vary between the plants.

The North and Central WWTPs generally operate within the discharge permit limitations. The South WWTP has not achieved consistent permit compliance and experiences extreme influent flow peaks during wet weather events.

ES.2.2 Collection and Conveyance Systems

The City/Parish collection system is divided into three major service areas: North, Central and South. The Central system is primarily a gravity network. The South and North systems have both a gravity network and a pressure transmission network. The system includes over 400 pump stations and approximately 1,880 miles of force main and gravity sewer serving approximately 270 square miles.

The collection system is mostly 8-inch pipe which comprises approximately 85% of the gravity system. Most neighborhoods are served exclusively by a network of 8-inch sewers. The areas drain, or are pumped, to larger diameter sewers which ultimately flow to one of the main trunk lines leading to the plants.

ES.3 Model Analysis and Verification

In order to develop an alternative sewer system management plan, CDM collected existing system information from the City/Parish, including the existing *HydroWorks*

models collectively covering the entire City/Parish collection system, flow monitoring and rainfall data collected at various sites between 1996 and 2003, and GIS files showing the delineations of model sewer basins and the collection system. The model contains approximately 1,282,000 linear feet of gravity sewer, 3,822 manholes listed as nodes within the model, and 1,142,000 linear feet of force main. The models also include data for 296 pump stations.

Based on the modeled storm event, there are capacity deficiencies severe enough to create overflows at 387 locations in the system. Because the model is a representation of the system which has been executed using an evenly distributed, stationary rainfall, it is important to recognize that the model is capable of indicating deficiencies and bottlenecks rather than predicting the actual locations and volumes of overflows. Overflows in the model are used as an indicator of capacity deficiency rather than a means of identifying specific overflow locations.

Overflows that occur in gravity lines upstream of pump stations generally indicate insufficient capacity at the pump station. Based on the model results, an estimated one hundred local pump stations lack sufficient capacity to drain the neighborhoods they serve. The remaining overflows indicate capacity deficiencies due to undersized gravity sewers.

ES.4 Proposed Solution

The City/Parish wishes to develop a solution that focuses on fixing major portions of the existing infrastructure rather than building additional new facilities. This remedial action plan first looks at reducing system inflows by rehabilitating and upgrading local sewers. The plan then identifies wastewater collection and transmission system improvements that will convey future base wastewater flows and wet-weather flows without surcharging or overflows for the design storm event. Increased sewer and pumping capacity will be required to accommodate some level of RDII during wet-weather as well as dry-weather flow associated with growth. Finally, the plan addresses treatment plant modifications to assure all the flow in the system is treated according to Louisiana Pollution Discharge Elimination System (LPDES) permit requirements. The recommended improvements have been divided into three improvement categories as defined below.

ES.4.1 Category 1: Comprehensive Sewer Rehabilitation and Pump Station Upgrades

ES.4.1.1 Comprehensive Sewer Rehabilitation

A comprehensive rehabilitation approach consists of rehabilitation of sewer basins that do not meet infiltration and inflow (I/I) control standards. The recommended approach for the City/Parish to take in areas where RDII reduction is targeted is to begin with comprehensive rehabilitation of the public sewer system, including the service laterals up to the property line. Comprehensive sewer rehabilitation methods including lining, pipe bursting, and pipe replacement or relief sewers. Point repairs may also be required for lines that are generally in compliance with I/I control

standards and for which only a specific location requires repair to repair structural defects.

The sewer rehabilitation strategy developed for the North, Central and South treatment plant basins assumes all areas where RDII currently exceeds 10 percent of the rainfall volume will receive comprehensive rehabilitation. The rehabilitation in each of the basins with R-values in excess of 0.10 is considered part of the Category 1 improvements.

The first basins to be scheduled for rehabilitation are generally those with the highest existing R-values. Several basins in the North area have the highest R-values; however, the Central area has numerous basins with moderate to high R-values indicating the sewer lines in this area are generally in worse condition than other areas of the City's system. A greater portion recommended for comprehensive rehabilitation. The South system is generally in significantly better condition than the other systems; hence a lower percentage of the system requires rehabilitation.

In areas where this approach does not achieve the desired level of RDII reduction or in areas where there are known significant sources of RDII on private property from system investigations, additional rehabilitation of the remaining service laterals on private property is recommended. The City/Parish currently has a sewer ordinance in place that provides the authority to require customers to remove sources of extraneous flow from the sanitary sewer system and to fine customers who fail to do so. The State of Louisiana Constitution contains a public purpose doctrine that requires public money to only be spent for a public purpose; however, the Constitution contains exemptions to the public purpose doctrine when it can be demonstrated that the public funding would be used for the purpose of assisting needy residents. Additionally, the City/Parish could use funding that was not considered to be public (i.e. "insurance") to rehabilitate private laterals. The City/Parish could also use funds that would be contributed in fines toward Supplemental Environmental Projects (SEPs). Special legislation that would allow the use of public funds for the repairs of private service laterals could also be sought.

ES.4.1.2 Pump Station Modifications

Forty-three pump stations in the North CSD area, three pump stations in the Central CSD area, and 41 pump stations in the South CSD/STN area could not overcome the system head required to allow the pump stations to pump into the system. It is difficult to assess the improvements required to allow all the pumps stations to operate; therefore, detailed field investigation of each pump station is required prior to determining the specific improvements required for each pump station. Improvements may require minor adjustments, or may require pump, motor or impeller replacement.

ES.4.2 Category 2: Transmission and Conveyance System Improvements

The model indicates overflows will occur even with sewer system rehabilitation if additional capacity improvements are not made. Capacity upgrades to the

City/Parish existing pump stations or the construction of new pump stations will be required to convey wet-weather flows and to prevent overflows upstream of the pump station. Most pump station capacity improvements identified by the model require less than 12 MGD, with a large percentage of pump stations requiring upgrade of less than 1 MGD. In the South service area, the model indicates several pump stations require significant capacity increases. A more detailed listing of the pump station and pipelines requiring capacity increases are provided in the Revised Second Remedial Action Plan as provided in Appendix B. The Category 2 improvements are identified by service area below.

North CSD/STN Area: minor capacity upgrades are required at 16 pump stations. The capacity increases required are generally less than 2 MGD. Pump Station 241 requires an increase of 12.5 MGD, which is the largest increase in the service area. Pipeline capacity improvements include replacement of approximately 37,000 linear feet (LF) of replacement gravity sewer, installation of approximately 84,000 LF of new parallel gravity sewer, approximately 51,000 LF of replacement force main, and 2,700 LF of parallel force main.

Central CSD Area: Capacity upgrades are required at three pump stations, with the Pump Station 2 requiring approximately 17 MGD of additional capacity. Pipeline capacity improvements include replacement of approximately 22,000 LF of replacement gravity sewer and installation of approximately 38,000 LF of new parallel gravity sewer. Based upon model results, no new force main based upon capacity needs is required in this service area.

South CSD/STN Area: Capacity upgrades are required at 35 pump stations, with the largest upgrades required at Pump Station 57, Pump Station 58, and Pump Station 514. It is assumed this will require construction of a new pump station or significant increase to the existing pump station wet well and pump/pipe systems. Pipeline capacity improvements include replacement of approximately 126,000 LF of replacement gravity sewer, installation of approximately 174,000 LF of new parallel gravity sewer, approximately 26,000 LF of replacement force main, and 7,000 LF of parallel force main.

ES.4.3 Wastewater Treatment and Flow Equalization

The peak flows predicted by the model for the North WWTP and Central WWTP are slightly less than the plants' current treatment capacities. The flows predicted for the South WWTP are significantly above the capacity of the plant and cannot be managed through pump station and flow control. Based upon the predicted increase in flow to the South WWTP and the historical performance of the treatment plant, the following improvements to the treatment plant are recommended.

- ***New Headworks and Flow Equalization Basin*** – Peak flows to the treatment plant from the South CSD and the South STN will be 273 MGD. If the South WWTP is upgraded to a peak capacity of 200 MGD, a 19 million gallon (MG) flow equalization facility is required. The construction of a new headworks facility with screening, grit removal facilities and influent pumping in the vicinity of the

required 19 MG equalization basin is required. With a new headworks facility, the two poorly functioning headworks facilities at the South WWTP can be eliminated.

- *Upgrade the South WWTP to a 200 MGD Activated Sludge WWTP* – Abandon the trickling filters and construct facilities for a new activated sludge process.

ES.5 Construction Sequence and Schedule

A project schedule has been developed that reflected the design, bidding, construction, and start-up of the projects included in Categories 1, 2 and 3. As required by the Consent Decree, the schedule reflects a completely operational system by January 2015, with milestones noted for completion of individual projects. The construction projects included in the schedule allow the City/Parish to comply with the requirements of the Consent Decree for reduction of SSO within the collection area and for the discharge from the wastewater treatment plants to be within permit limits. The schedule for each category of improvements is provided below.

<i>Category</i>	<i>Start Construction</i>	<i>Complete Construction</i>	<i>Fully Operational</i>
1: Comprehensive Sewer Rehabilitation and Pump Station Upgrade			
Comprehensive Sewer Rehabilitation	March 2006	August 2013	March 2014
Pump Station Upgrades	October 2006	September 2008	December 2008
2: Conveyance/Transmission System	October 2010	July 2014	November 2014
3: Wastewater Treatment/Flow Equalization			
Headworks and Flow Equalization	May 2007	May 2010	September 2010
Pipe to from Flow Equalization to South WWTP	August 2008	August, 2009	September 2011
South WWTP Improvements	May 2007	April 2010	September 2011
Pipeline to Mississippi River	April 2008	August 2009	December 2009

ES.6 Program Costs

The cost estimate for the recommended improvements includes administration, design, contingency, bidding, and construction costs and includes an allowance for normal inflation. The costs do not include land acquisition required for easements or land for new facilities. The opinion of probable construction cost for each of the categories of improvements is discussed below. Additional cost information is provided in Appendix E. The program costs are shown below.

<i>Program Category of Improvements</i>	<i>Total</i>
Category 1: Collection System Basin Rehabilitation SSO Collection System	\$199.1 million
Category 2: Transmission/Conveyance System Improvements Pump Station & Transmission	\$233.7 million
Category 3: Treatment Plant and Flow Equalization WWTP & Flow Equalization Basin	\$68.0 million
Total Program Cost	\$500.8 million

ES.6.1 Category 1: Comprehensive Sewer Basin Rehabilitation and Pump Station Upgrades

The projects have been separated to generate bid packages valued at between \$4 million and \$6 million. This cost includes manhole and public-side lateral rehabilitation. An additional cost of \$900 per service lateral is included for any private side lateral rehabilitation required to reduce the basin R-values. The preliminary opinion of probable construction cost for the comprehensive sewer rehabilitation in Category 1 is \$170 million to rehabilitate approximately 350 miles of sewer. The rehabilitation costs are based upon a unit price ranging between \$80 and \$90 per linear foot of pipe rehabilitated and \$5 to \$10 per foot of pipe for engineering and field work.

Eighty-seven pump stations were identified in the model as requiring an increase in head, likely due to pumping against another pump station in the conveyance system. These improvements are divided into seven construction contracts valued between \$3 and \$6 million per project for a preliminary opinion of probable construction cost of \$29.2 million. The cost for pump station evaluation and mechanical improvements was estimated as 30 percent of the cost for a new pump station.

The total preliminary opinion of probable construction cost for Category 1 improvements is approximately \$200 million.

ES.6.2 Category 2: Pump Station and Transmission/Conveyance System Improvements

These improvements are generally split into pipe line projects and pump station projects. The pipeline project contracts are split into construction projects generally valued between \$3 million and \$12 million. The pump station capacity increases are generally significant enough to warrant new pump stations or increases in wet well capacity and are considered complex construction projects. Several of these pump station construction contracts will be over \$20 million each. The unit cost of the installed pipe ranges from \$5.50 to \$20 per inch diameter per foot. The price variation is due to depth of installation and material for pipe. The total Category 2 preliminary opinion of probable construction cost is \$232 million.

ES.6.3 Category 3: Flow Equalization and Wastewater Treatment Improvements

Category 3 costs include costs associated with treatment plant improvements and flow equalization. No treatment plant improvements are required at the North WWTP or Central WWTP. Process modifications are required at the South WWTP to comply with Consent Decree requirements and to ensure long-term compliance with all Clean Water Act requirements. The cost of the Category 3 improvements includes construction of a new headworks/flow equalization facility and upgrade of the South WWTP to an activated sludge facility/peak flow treatment facility. The preliminary opinion of probable construction cost for Category 3 is \$68 million.

ES.7 Operation and Maintenance

Implementation of the revised RMAP2 program will have a number of implications related to operations and maintenance (O&M) costs to the City/Parish. To evaluate these impacts, CDM obtained the detailed City/Parish line item wastewater budget and used this budget to determine how operation and maintenance costs would be expected to change upon implementation of the improvements program.

ES.7.1 Collection System O&M Costs

A significant portion of the sewer system has average groundwater infiltration rates of 3,000 gallons per foot per year or greater. It was assumed that comprehensive rehabilitation would remove 80 percent of this groundwater infiltration.

Operation and maintenance savings will be achieved as a result of the comprehensive rehabilitation program. A comprehensive program will result in decreased overflows and stoppage responses as well as a decrease in the frequency of cleaning needed for the rehabilitated pipes. At the completion of the RMAP2 comprehensive rehabilitation program, it is anticipated that the City/Parish costs for emergency point repairs of structural failures will be decreased from its current \$2,000,000 annual cost to approximately \$1,100,000 (a \$900,000 savings) given that much of the oldest sewers will be included in the rehabilitation program. In addition, it is anticipated that the responsive (emergency) maintenance costs will be reduced by approximately \$460,000 based on a reduced cleaning frequency that will be required in the rehabilitated areas.

ES.7.2 Pumping O&M Costs

System pumping costs are approximately \$0.06 per 1000 gallons of wastewater pumped to the treatment plant. Infiltration reduction from comprehensive rehabilitation is projected to reduce pumping costs in the system by approximately \$275,000 annually. Design improvements can be made to the pump stations during the upgrades that will have an overall benefit in terms of reduced power usage and therefore result in potential energy savings. Energy savings can be realized by proper pump selection and operation of pumps near their best efficiency point.

ES.7.3 Wastewater Treatment Plant O&M Costs

Based on the City/Parish budget, treatment plant power and chemical costs average approximately \$0.18 per 1000 gallons treated. The average daily dry-weather influent flow to the treatment plant will be reduced with the implementation of the rehabilitation program. The groundwater infiltration to the system will be significantly reduced, thereby reducing flow to the South WWTP. An annual savings in treatment costs of approximately \$890,000 per year is expected with implementation of the recommended program.

The system modifications at the treatment plant will add approximately \$500,000 in annual power cost. There will be a decrease in power costs of \$400,000 due to the elimination of the two primary effluent pump stations. There is a projected savings of approximately \$400,000 in chlorine, sulfur dioxide, and NaOH costs associated with the disinfection system that will no longer be incurred. The two old maintenance

Section 1

Introduction

1.1 Project History

On March 14, 2001, the City of Baton Rouge/Parish of East Baton Rouge (City/Parish) entered into a Consent Decree with the Environmental Protection Agency (EPA) and the Louisiana Department of Environmental Quality (LDEQ). The Consent Decree outlines a scheduled program of system improvements to correct historical overflows and by-passes that have occurred within the collection system and violations of effluent discharge limits at the three wastewater treatment plants (WWTP). The Consent Decree provided alternatives for system correction and required completion of construction and full operation by specific dates for three of the alternatives.

Prior to December 2002 the City/Parish elected (by vote of City Council) to select Alternative 7, which provided for construction of deep underground tunnels, removal of numerous pump stations by connection to the tunnel system, and construction of tunnel pump stations. This alternative included an annual expenditure of \$3 million in collection system rehabilitation. The City/Parish moved forward with several aspects of this alternative, including the selection of design consultants for the tunnels and tunnel pump stations.

In April 2005, representatives of the City/Parish spoke with EPA about amending the Consent Decree to include a more aggressive approach to sanitary sewer overflow (SSO) abatement – namely comprehensive sewer rehabilitation as an alternative to the deep tunnel system. In late April, 2005, EPA agreed not to impose fine-related deadlines in the current Consent Decree to allow the City/Parish 90-days (beginning May 1, 2005) to verify and develop the comprehensive sewer rehabilitation option more fully. The previously selected alternative did not address the root of the problem by providing only limited rehabilitation of the collection system, which is the source of inflow and infiltration (I/I) into the system. The tunnel and pump station system would not correct the problems within the system.

1.2 Purpose and Objective

The City/Parish subsequently hired Camp Dresser & McKee Inc. (CDM) to provide engineering services to evaluate the existing sewer system model and develop a plan which would address the causes of the rainfall dependent inflow and infiltration (RDI) and resulting system overflows. This report defines a specific plan for rehabilitation of Baton Rouge's collection system so that it will operate without overflow during the design modeled storm event. The primary focus of this plan is to address the cause of RDI and to develop economical corrections to eliminate overflows and treatment plant permit violations. The result of CDM's analysis is the development of a Revised Second Remedial Measures Action Plan (RMAP2) as defined in the Consent Decree. The RMAP2 is the second phase of improvements to be undertaken by the City/Parish. The first RMAP



(RMAP1) improvements, as outlined in the Consent Decree, are underway and anticipated to be completed on schedule.

The proposed Revised RMAP2 focuses on repair and upgrade of existing facilities while minimizing construction of additional infrastructure. The plan identifies the combination of system improvements needed to control wet weather overflows during the simulated planning condition, and it includes a combination of sewer rehabilitation to reduce RDII, system conveyance upgrades to address capacity problems, and improvements at the South WWTP to achieve permit compliance during both wet and dry weather conditions.

This report also provides a schedule for completion of specific collection system and wastewater treatment plant improvement projects and for implementation of a collection system rehabilitation program. The schedule for implementation is based on meeting Consent Decree requirements that the work be completed by January 1, 2015. Annual spending requirements are provided to assure that the City/Parish understands the rate and funding implications of the recommended program.

The final work product includes a proposed (red-lined) modified Consent Decree (**Appendix A**) revised Remedial Measures Action Plan 2 (RMAP2)(**Appendix B**) and all other proposed Consent Decree modifications for LDEQ and EPA review and approval.

1.3 Project Approach

To accomplish the stated objective, an updated hydraulic analysis has been conducted on the City/Parish sanitary sewer collection system. This analysis consisted of four major tasks as described below.

Task 1 - Verification of System Flows

The main purpose of this task was to make sure the flow input is representative of wet weather conditions and the estimates are adequately documented for review.

The subtasks associated with this task were as follows:

- a. Obtain and review historical flow monitoring and rainfall data.
- b. Confirm flow analyses to determine simulated rainfall dependent infiltration and inflow rates.
- c. Review and revise sub-basin delineations and flow assignment. Basins were consolidated as needed to obtain an accurate input scheme.
- d. Verify the modeled system by comparing predicted flow outputs to known conditions throughout the system.

Task 2 - Local System Improvement Plan

As part of this task, a plan for making local system improvements needed to address current and predicted future capacity issues was developed. The plan specifies the combination of sewer rehabilitation, gravity sewer improvements, and pump station and force main improvements needed to mitigate overflows in the local basins. The subtasks included:

- a. Review flow conditions and identified bottlenecks and areas where excessive flows are generated. Reviewed flow monitoring data, where available.
- b. Prepare sewer rehabilitation plan, if appropriate, for basin. Determine likely flow reduction that can be achieved.
- c. Determine conveyance and pump station improvements needed to meet system capacity requirements with assumed I/I reduction levels.
- d. Compile improvement projects and prepare construction cost estimates.

Sewer overflows are generally caused by insufficient conveyance capacity in gravity sewers or pumping facilities. Maintenance problems including debris blockage, collapsed pipes and mechanical failure do not factor into this analysis. The local system improvement plan identifies projects needed to provide sufficient capacity to convey sub-system flows to the trunk sewer system. These local projects focus on rehabilitation of existing sewers in areas where high RDII is expected based on available information. However, gravity sewer and pump station improvements were included where additional capacity is needed to meet planning conditions.

Task 3 - Regional Conveyance and Treatment

In many areas, there is insufficient trunk sewer capacity to convey the local basin flows to the existing treatment plants. This task determined the conveyance and treatment needs to provide treatment for the flows generated in each local basin. The subtasks included:

- a. Identify trunk system bottlenecks and deficiencies.
- b. Develop key conveyance projects including consideration of diversions between wastewater treatment plant service areas if these would be beneficial.
- c. Determine treatment and/or equalization requirements at each plant based on overall collection system improvements.

Work in this task also determined treatment plant modifications needed to treat or equalize peak wet weather flows.

Task 4 - Implementation Plan

In Tasks 2 and 3, system modeling was used to determine the projects required to achieve the level of service desired by the City/Parish. Task 4 set a construction

sequence and investment schedule to implement the improvements by 2015 as required by the Consent Decree. Subtasks of Task 4 include the following:

- a. Determine necessary sequence of construction to prevent overloading of individual facilities.
- b. Prepare planning level cost estimates for all recommended improvements in the plan.
- c. Determine a construction schedule that meets the financial objectives of the City/Parish.
- d. Prepare documentation and exhibits for use in EPA negotiations and assist the City/Parish in presenting the plan to EPA.

1.4 Report Structure

The primary purpose of this project is to identify the alternative plan and provide a proposed Revised RMAP2 along with supporting information needed by the City/Parish to implement the Revised RMAP2 plan. This data includes the design and construction cost, construction sequence, implementation schedule and cash flow requirements. The execution and results of these tasks are discussed in the remaining sections of this report as follows.

Executive Summary – A summary of the information contained in Sections 1 through 5 is provided as an overview of the report. This section outlines the existing conditions and recommended program. Details regarding the program development can be found in the report sections.

Section 1: Introduction – This section includes a summary of the Consent Decree history and a description of the purpose of the model verification and development of the Revised Second Remedial Action Plan.

Section 2: System Description and Data – This section includes a description of the existing treatment and collection/conveyance system as well as modeling input information and system flow monitoring data. Wastewater flow assumptions, design storm and model verification are discussed.

Section 3: Existing System Assessment – This section provides a discussion of the existing model limitations, analysis of system improvements including sewer system rehabilitation approaches, and discussion of wet weather management alternatives.

Section 4: Improvement Plan – In this section, the improvement plan for the collection and conveyance system is developed based on model results for each of the major wastewater treatment plant service areas. Recommended improvements for wastewater treatment and wet weather management are also presented.

Section 5: Implementation Plan – This section includes development of an implementation schedule based upon construction constraints as well as financing ability of the City/Parish. The estimated program costs including construction, design and implementation for the recommended improvements is presented along with the changes in operations and maintenance costs. A cash flow analysis based upon the estimated costs and implementation schedule is presented.

Section 2

System Description and Data

The City of Baton Rouge/Parish of East Baton Rouge (City/Parish) operates three wastewater treatment plants (WWTP) and most of the collection systems draining to these treatment plants. The portions of the collection system not owned by the City/Parish are privately owned and operated by suburban communities. There are no hydraulic connections between each of these service areas. The North and South WWTP service areas contain both gravity conveyance systems as well as pressure transmission networks. The Central WWTP service area contains a primarily gravity collection system.

2.1 Wastewater Treatment

The City/Parish owns and operates the North WWTP, Central WWTP, and South WWTP. The delineation of the service area and location of the wastewater treatment plants are located as shown in Figure 2-1. The design average daily flow and peak hourly flow capacity in million gallons per day (MGD) for each plant is listed in Table 2-1.

*Table 2-1
Treatment Plant Flow Information*

<i>Treatment Plant</i>	<i>Design Average Daily Flow¹ (MGD)</i>	<i>Design 1-hour Peak Flow (MGD)</i>	<i>Actual Average Dry Weather Influent Flow (MGD)</i>
North	54	130	15-20
Central	32	65	7-10
South	54	120	32-35

¹ Per Louisiana Pollution Discharge Elimination System (LPDES) Permit

The wastewater treatment plants are permitted as secondary treatment facilities. All three discharge directly into the Mississippi River or to its tributary. The discharge limits require an average monthly limit of 30 milligrams per liter (mg/l) for 5-day biochemical oxygen demand (BOD₅) and total suspended solids (TSS) and a weekly maximum average of 45 mg/l for both of these parameters. The plants have fecal coliform discharge limits of 200 colonies per 1000 milliliters (ml) average and 400 colonies per 1000 ml peak. Because the treatment plants provide disinfection by chlorination and removal of chlorine prior to discharge through the use of sulfur dioxide, the plants also have specific total chlorine residual (TRC) limitations, which vary between the plants.

The treatment process for all three plants generally includes preliminary treatment including screening and grit removal, primary clarification, biological treatment through trickling filters, secondary clarification, and disinfection through use of chlorine. The North and Central WWTPs generally operate within the discharge permit limitations. The South WWTP has not achieved consistent permit compliance

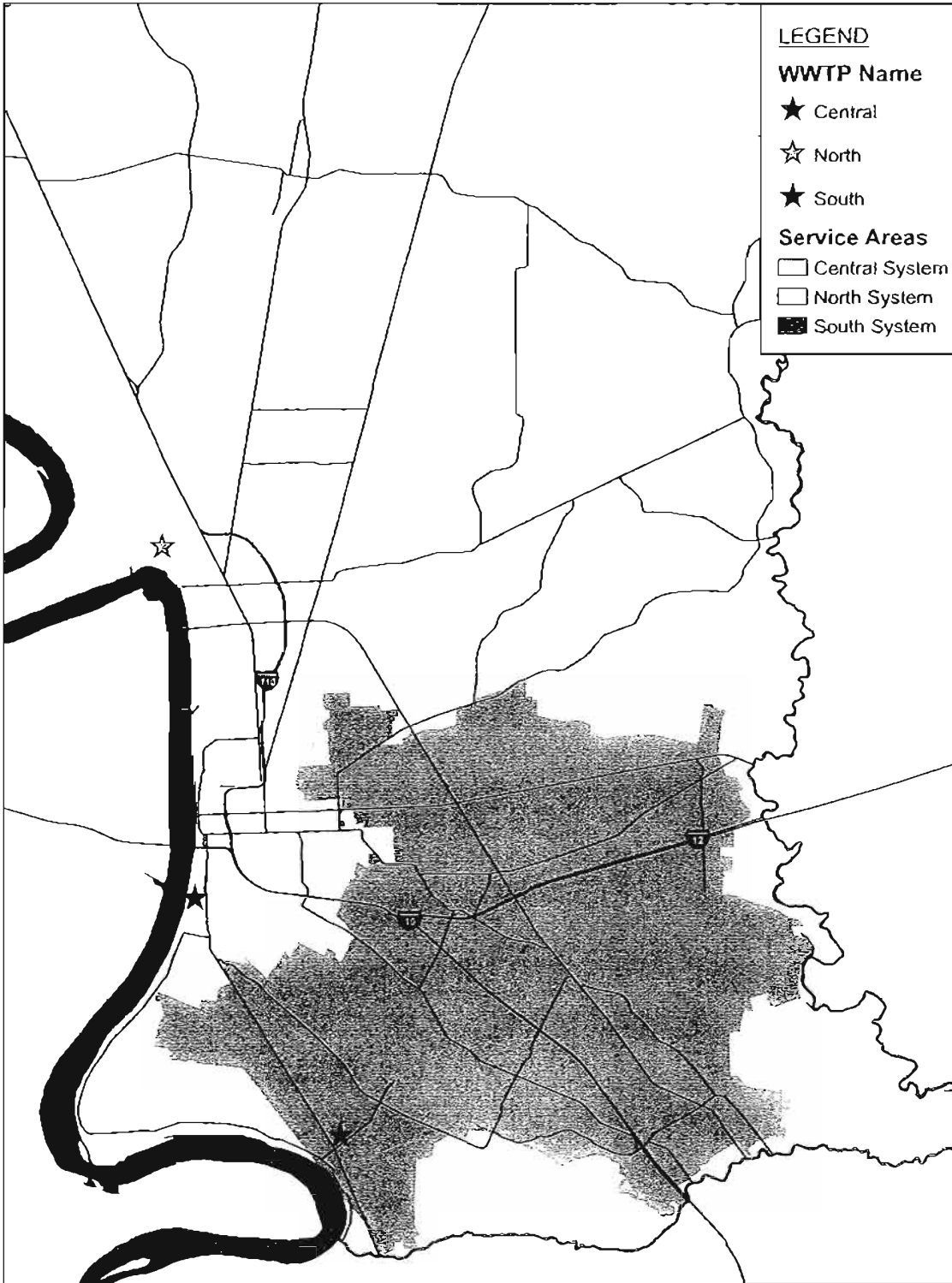

and experiences extreme influent flow peaks during wet weather events. Corrective action for this treatment plant is discussed in more detail in Section 4.4.

2.2 Collection System

The City/Parish collection system consists of local gravity collection sewers, gravity interceptors, force mains and over 400 pump stations. There are approximately 1,880 miles of force main and gravity sewer within the sewer system. The total area served by the tributary collection systems is approximately 270 square miles. Table 2-2 summarizes the length of gravity pipe within the collection system by pipe diameter. Pipe sizes with less than 500 feet of pipe were not included in this table.

**Table 2-2
Summary of Gravity Sewer Pipe Length**

<i>Pipe Diameter (in.)</i>	<i>Length (ft)</i>	<i>Pipe Diameter (in.)</i>	<i>Length (ft)</i>
4	600	24	78,000
6	57,900	27	4,500
8	7,375,800	30	48,900
9	700	33	3,800
10	349,500	36	72,500
12	231,100	42	21,300
15	153,600	48	21,400
18	127,000	>48	37,600
21	17,000		
Total Length of Pipe in Collection System (ft)			8,601,200

The City/Parish collection system is divided into three major service areas: North, Central and South. Each of these services area has a dedicated treatment plant. The Central system is primarily a gravity network. The South and North systems have both a gravity network and a pressure transmission network. It should be noted that there are short stretches of gravity sewers in both the North and South pressure networks.

The collection system is mostly 8-inch pipe which comprises approximately 85% of the gravity system. A map of the collection system is shown in Figure 2-2. Neighborhoods are served exclusively by a network of 8-inch sewers and drain, or are pumped, to larger diameter sewers which ultimately flow to one of the main trunk lines leading to the plants. A 54-inch gravity sewer and a 54-inch pressure sewer enter the North WWTP. Influent to the Central WWTP is pumped from three pump stations (PS59, PS1, and Louisiana State University (LSU)). LSU and PS1 join at the gate and become a single pipe just upstream of the Central WWTP headworks. The South WWTP is currently fed by a 72-inch gravity sewer and a 48-inch pressure sewer. A new force main that carries flow to the South WWTP has been constructed from

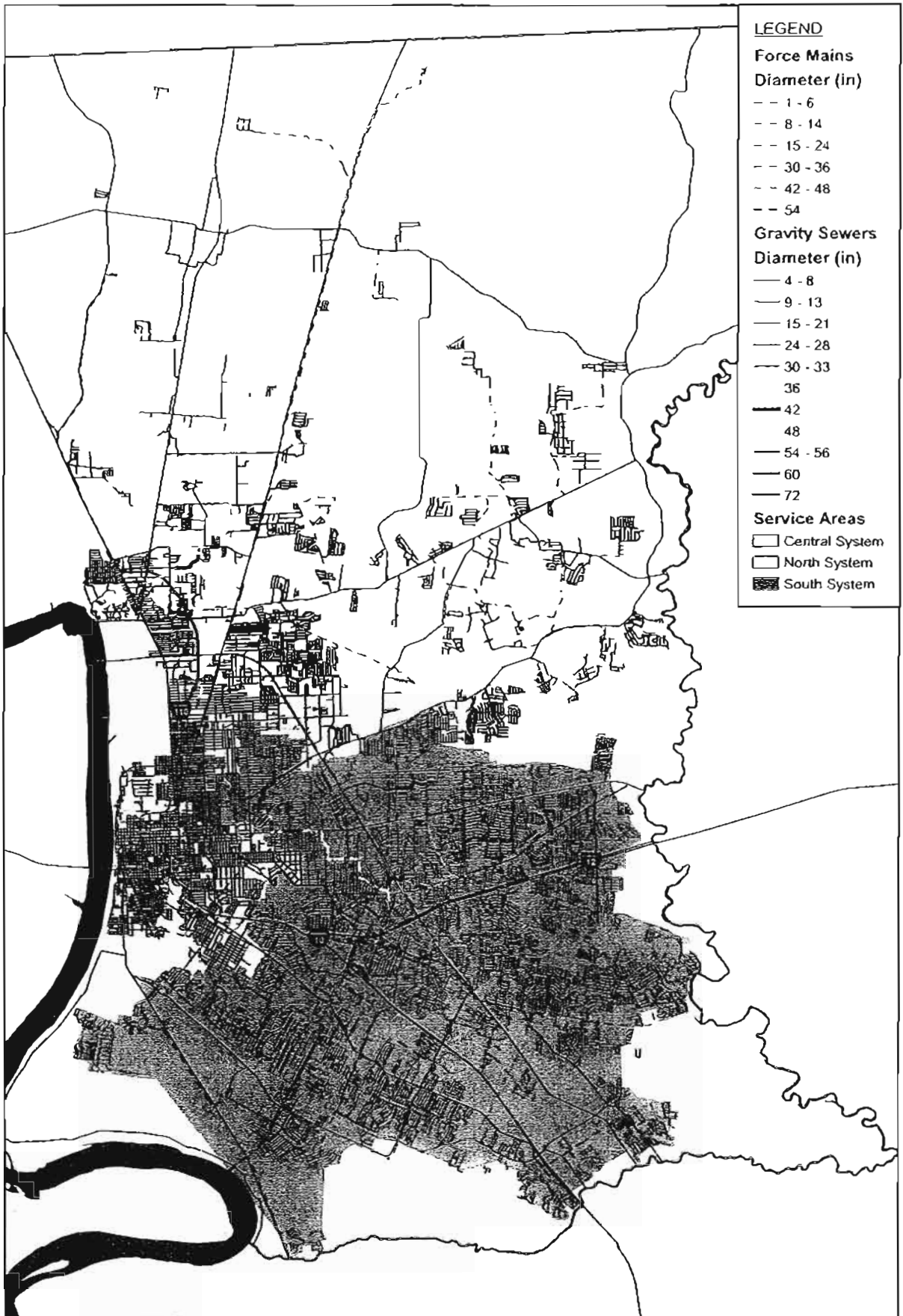

Nicholson to Gardere and serves the new developments along Burbank and Bluebonnet.

2.3 Hydraulic Model

In order to develop an alternative sewer system management plan, CDM collected existing system information from the City/Parish. The data provided included:

- Four *HydroWorks* models collectively covering the entire City/Parish collection system. The hydraulic model for each system generally contains the gravity sewers greater than 8-inches in diameter and major pump stations and forces mains.

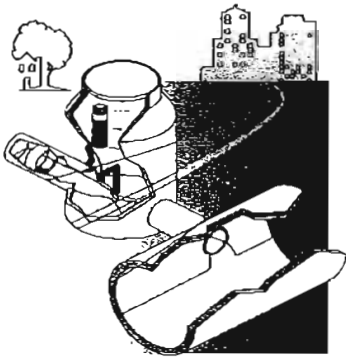

- Flow monitoring and rainfall data collected at various sites between 1996 and 2003.
- GIS files showing the delineations of model sewer basins.
- GIS files showing the entire collection system with sewer sizes.

The reliability of the available data was assessed using the model. The data was reviewed and evaluated for use in the development of an overflow elimination plan. The *HydroWorks* model was delivered as four networks. These networks were labeled as follows:

- North – North pressure and gravity system network
- SSTN - South pressure system network
- SCSD - South gravity system network
- CCSD - Central system network

The models represent approximately 459 miles of sanitary sewer and force main, or approximately 24 percent of the overall collection system. The models also include data for 296 pump stations. Smaller pumping stations are generally not included in the system model. Network data and wastewater flow assumptions are summarized below.

2.3.1 Network Data

The model “networks” identified above consist of the layout or configuration of system elements including pipes, manholes, pumps, force mains, valves and outfalls. The physical system in the model network also contains surface hydrology data and some dry weather flow data (population and base flow). The physical data describing the geometry of the network is also associated with the network. This data includes sewer and manhole diameters, sewer invert elevations and pump performance curves. For each manhole, the network data also defines how the model simulates

flooding, i.e., the action the model takes when the hydraulic grade line exceeds the rim elevation of the manhole when the manhole is likely to overflow.

The model contains approximately 1,282,000 linear feet of gravity sewer, 3,822 manholes listed as nodes within the model, and 1,142,000 linear feet of force main. Table 2-3 summarizes some of the network information contained within the developed model.

**Table 2-3
Modeled Network Information**

System	Gravity Pipe (feet)	Manholes	Force Main (feet)	Pump Stations
North	427,418	1,325	615,279	104
CCSD	179,829	457	20,239	14
SCSD/SSTN	674,798	2,040	506,099	178
Total	1,282,045	3,822	1,141,617	296

2.3.2 Flow Input and Data Groups

Additional model input is contained in data groups. Several data groups were present in the model provided by the City/Parish. These included wastewater flow, base flow, rainfall and real time control (RTC) groups. There were also level and inflow groups included in the model; however, these were determined to be irrelevant for evaluation of sanitary sewer overflows (SSOs) under design storm conditions because, for the City/Parish model, these groups supply operating data for specific historical events.

For purposes of flow monitoring and model development, the collection system was separated into sewer basins. These basins are small units in which the pipes converge to a point. Data is input into the collection system model by basins. Data related to a particular event or controlled by specific dates simulate a particular circumstance and are not necessary for evaluating sanitary sewer overflows.

Wastewater Flow Data Group

The wastewater flow data group defines the amount and variation of wastewater flow. Since flows are assigned to each basin on a per capita basis, a basin population is required. The per capita flows in the wastewater flow group range from 35 to 90 gallons per capita per day (gpcpd).

The model contains 1,175 sewer basins with wastewater flow assignments. An additional 313 basins have wastewater flow assigned but no service area. For these basins, the flow and population assigned in the existing appear to represent the commercial and industrial wastewater flow. This flow is converted to population equivalents (PE) by dividing by 100 gpcpd. Based on the data in the model,

commercial and industrial flow is represented by a PE of 63,843 with a flow of 6.38 MGD. The total population represented in the model is 431,627, with a residential population of 367,784 and a commercial/industrial PE of 63,843. The 2000 U. S. Census puts the City/Parish population at 412,447. The difference is likely due to areas not served by sewers or not represented as population, such as the entire LSU campus. The flow assignments in the model appear to represent 2001 conditions. Current year (2005) flows are slightly less than those simulated in the model. Based on information provided to CDM by the City/Parish, the North and Central service areas would not see future increases in wastewater flows due to growth. The South service area is predicted to sustain continued growth, thus necessitating more capacity improvements in this area than required in the North and Central service areas.

Baseflow Data Group

Baseflow input is part of the network input and is a constant flow input assigned to individual manholes in the network. In collection system modeling, baseflow typically is used to represent groundwater infiltration into the system. It appears that baseflow has also been used to represent other system inflows such as the contribution from LSU. The system model includes baseflow inputs at 1,151 locations ranging from 0.00023 to 0.5 MGD. The total of all base flow input in the model is 24.85 MGD, which appears to represent groundwater infiltration throughout the service area as well as a few selected point inflows.

Rainfall Data Group

The rainfall input to the model is used to simulate the process of rainfall dependent infiltration and inflow (RDII). RDII is the rain water that leaks into the sanitary sewer system and is the cause of nearly all sewer overflows in the modeled system.

The rainfall group in the model provided by the City/Parish contains a single rainfall event dated September 5, 1977. This storm begins at 10 AM and concludes at 10 PM (22:00). The hourly rainfall input nearly matches the rainfall recorded at the Baton Rouge Metropolitan Airport on that date. This storm has been used as the design storm for developing previous remedial action plans. The rainfall data group input consists of 4.41 inches of rainfall over the 12-hour period. A multiplier of 0.89 was applied to the hourly rainfall, presumably to convert the point rainfall to an equivalent rainfall depth over a large area. The rainfall information is discussed further in Section 2.4. This rainfall data is summarized in Table 2-4. The model networks reference up to 20 different rainfall patterns, with this rainfall event the only one provided. This event was verified by statistical analysis of historical data and is used for evaluation of the sanitary sewer system.

Infiltration

- Rainfall Dependent I/I Input at 1,184 load points with an average $R=0.061$ over 90 square miles of sewered area

2.4 Flow Verification

Flow monitoring and rainfall records obtained for several permanent monitoring sites were evaluated to check the flow data contained in the model. The City/Parish has 16 permanent meters. Records were obtained which cover the period 1997 to 2003. A flow decomposition procedure was used to segregate the flows into base wastewater flow (BWF), groundwater infiltration (GWI) and RDII.

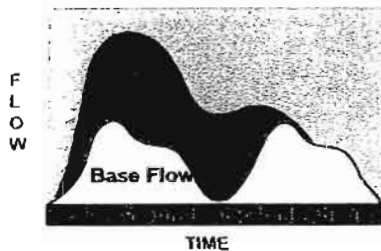

The decomposition process first looks at dry days to determine the dry-weather flow pattern at the site. The dry-weather flow is divided into BWF and GWI based on the assumption that the lowest observed flows in the record are likely equivalent to the GWI components. Next, the dry-weather flow as determined above is subtracted from the monitoring records on rainy days. The remainder is the RDII hydrograph. The volume of RDII can be determined from the hydrograph allowing calculation of an R-value.

Many of the flow monitoring records were found to have large changes in flow depth at various times in the record. This could indicate a failure to maintain the flow monitoring site or a result of construction activity upstream or downstream of the site. Using portions of the records that appeared to be reliable, R-values were found to vary between 2 and 20 percent with most in the range of 4 to 6 percent. This is consistent with the R-values used in the model; however, a more in-depth follow-up investigation is recommended to verify the areas where R-values exceed 10 percent.

2.5 Model Modifications

Results of the previously developed model were accepted by the Environmental Protection Agency (EPA) for use by the City/Parish to develop the First Remedial Action Plan (RMAP1) and the original Second Remedial Action Plan (RMAP2). This study verified the model parameters based upon the information provided. Changes to the model made as a result of the verification include: addition of a diurnal variation for wastewater flow, correction of some pumping curves so that flow decreased with increasing pumping head and modification of selected pipes and manholes which contained questionable data. Other minor changes were made to improve model initialization requirements and to improve model run speed. None of these modifications affected the overall system representation. In all cases, the modified system made the model a more realistic representation of the network.

As is the case with most sewer system hydraulic models, RDII is simulated using a standard surface water hydrologic technique, or a rainfall run-off model. The observed behavior of an RDII hydrograph is very similar to a flood hydrograph. In *InfoWorks*, if a rainfall group is present, then the model attempts to simulate rainfall

dependent flow. The simulation uses runoff surfaces defined in the sub-catchment data. The model includes a total of 1,499 sub-catchments. Of these, 1,184 have basin areas defined. The remaining sub-catchments have been defined to provide commercial/industrial point flows from areas that overlap the other sub-catchments. The sub-catchments are shown in **Figure 2-3**.

The RDII process is simulated by generating runoff from a small portion of the sub-catchment. This can be observed by comparing the total sub-catchment area to the total runoff area. The runoff surfaces are defined to be 100 percent effective; therefore, the ratio of runoff area to sub-catchment areas is the percent of rainfall that is loaded into the sewer network. This proportion is known as the R-value of the sub-catchment. The R-value represents the fraction of rainfall that enters the sewer system.

It should be noted that several sub-catchments were configured to contain runoff surfaces defined to be less than 100 percent effective. These few runoff surfaces were modified to be 100 percent effective while their associated contributing area was simultaneously decreased so as to not alter the total contribution of RDII. These modifications were made to ease testing of rehabilitation alternatives and, because the overall RDII was balanced, do not alter model performance.

In the model provided by the City/Parish, runoff surfaces were provided for 1,184 sewer basins. The R-values for these basins ranged from 0.0047 to 0.68. The area weighted average is 0.061 and the median R is 0.053. R-values for a very tight/low leakage sewer system would be 0.01 or lower and for a leaky system are generally 0.04 or higher. A summary of select R-values is provided in **Appendix C**.

2.6 Design Storm Considerations

Historically, the source rainfall frequency data has been the National Weather Service document TP-40 published in 1961. Because the data records used to develop TP-40 ended over 50 years ago, the recent rainfall record in Baton Rouge was evaluated. A statistical analysis using techniques similar to TP-40 was performed on the Baton Rouge Metropolitan Airport rainfall records covering 1948 through 2003. In this analysis, the 2-year and 5-year frequency rainfalls were determined for various storm durations. Results of the analysis are summarized in **Table 2-5**.

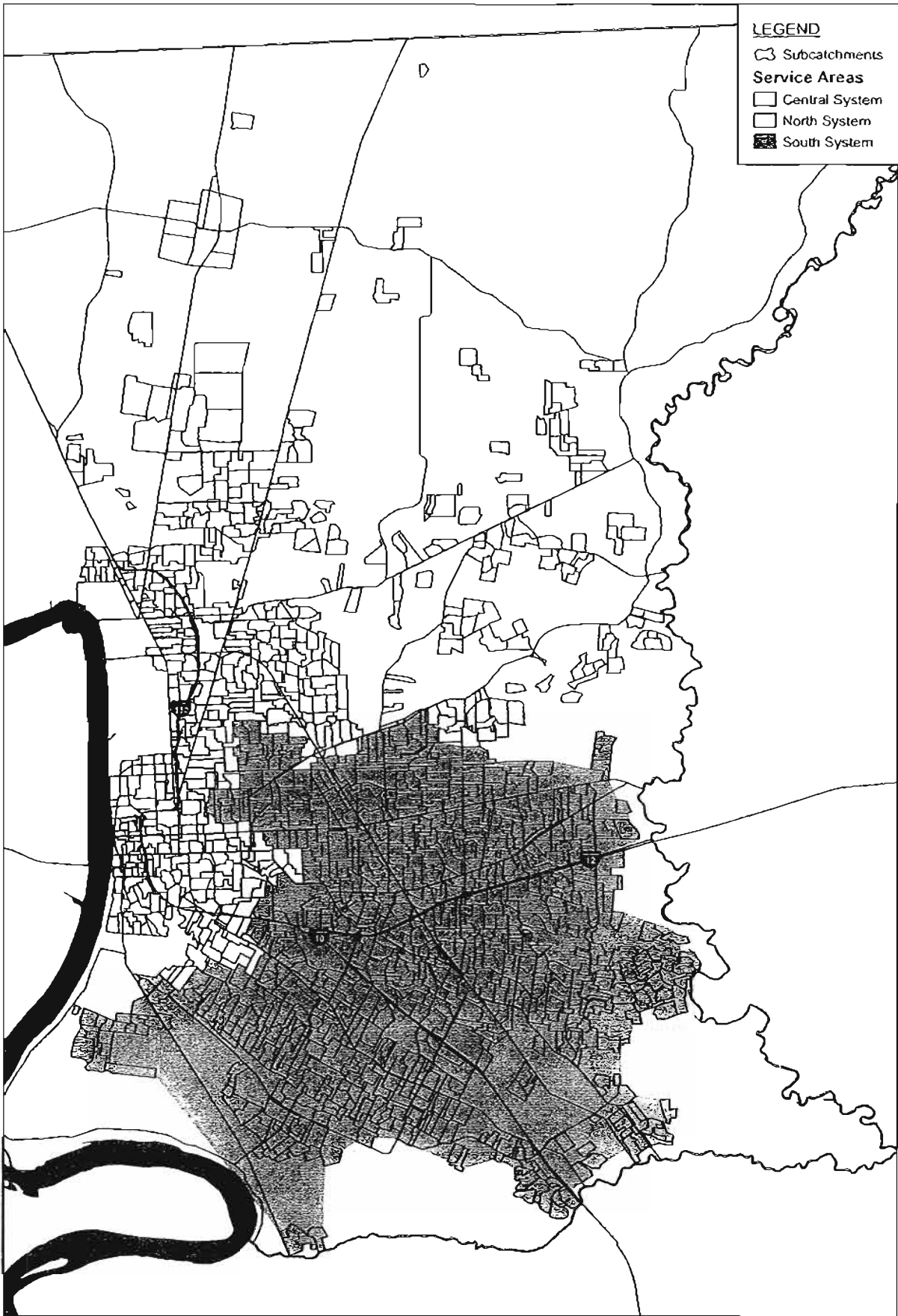

Table 2-5
Rainfall Volumes Computed in the Current Study

Storm	Current Study Estimate (in.)
2-yr, 12-hour	4.02
2-yr, 24 hour	4.67
5-yr, 12 hour	5.62
5-yr, 24 hour	6.51

Section 3

Existing System Assessment

3.1 System Deficiencies

To be consistent with the previous modeling efforts, the existing system has been evaluated in *InfoWorks* using the 2-Year, 12-hour storm event. The *InfoWorks* system model represents about 15 percent of all gravity sewers and 24 percent of all pipes in the Baton Rouge collection system. The model includes virtually all system components that are 12 inches in diameter or larger.

Nearly every neighborhood in Baton Rouge is served by a network of 8-inch sewers that drain to a pump station. Of the more than 400 pump stations in the Baton Rouge network, 296 are represented in the model. The primary gravity lines serving each local or neighborhood pump station are also included in the model. These local gravity lines account for much of the 54 miles of 8-inch sewer that have been included in the computer model.

Overflows in Baton Rouge are caused by leaky sewers and leaky private laterals that result in either insufficient pumping capacity or insufficient gravity sewer capacity. Based on the modeled storm event, there are capacity deficiencies severe enough to create overflows at 387 locations in the system. Because the model is a representation of the system which has been executed using an evenly distributed, stationary rainfall, it is important to recognize that the model is capable of indicating deficiencies and bottlenecks rather than predicting the actual locations and volumes of overflows. Thus, overflows in the model are used as an indicator of capacity deficiency rather than a means of identifying specific overflows.

Figure 3-1 shows the locations where overflows occur in the model. As shown, the system deficiencies are distributed throughout the collection system. There are capacity shortfalls in every major drainage network, and they occur in the remote lines as well as along the trunk collector sewers.

Overflows that occur in gravity lines upstream of pump stations generally indicate insufficient capacity at the pump station. Based on the model results, an estimated one hundred local pump stations lack sufficient capacity to drain the neighborhoods they serve. The remaining overflows indicate capacity deficiencies due to undersized gravity sewers. Without significant reduction in inflow and infiltration, overflows associated with capacity deficiencies may increase in number as the pump stations are improved because the upgraded pump stations will transmit more flow to downstream gravity lines and treatment plants.

Due to the age and poor condition of the collection system throughout Baton Rouge, a plan to reduce overflows must be regional and comprehensive. A comprehensive plan must account for project scheduling, location, and impacts from system

P:\MELANCON AUSSVR1\GIS\BatonRouge\Figures\Fig3-1.mxd 7/15/2005

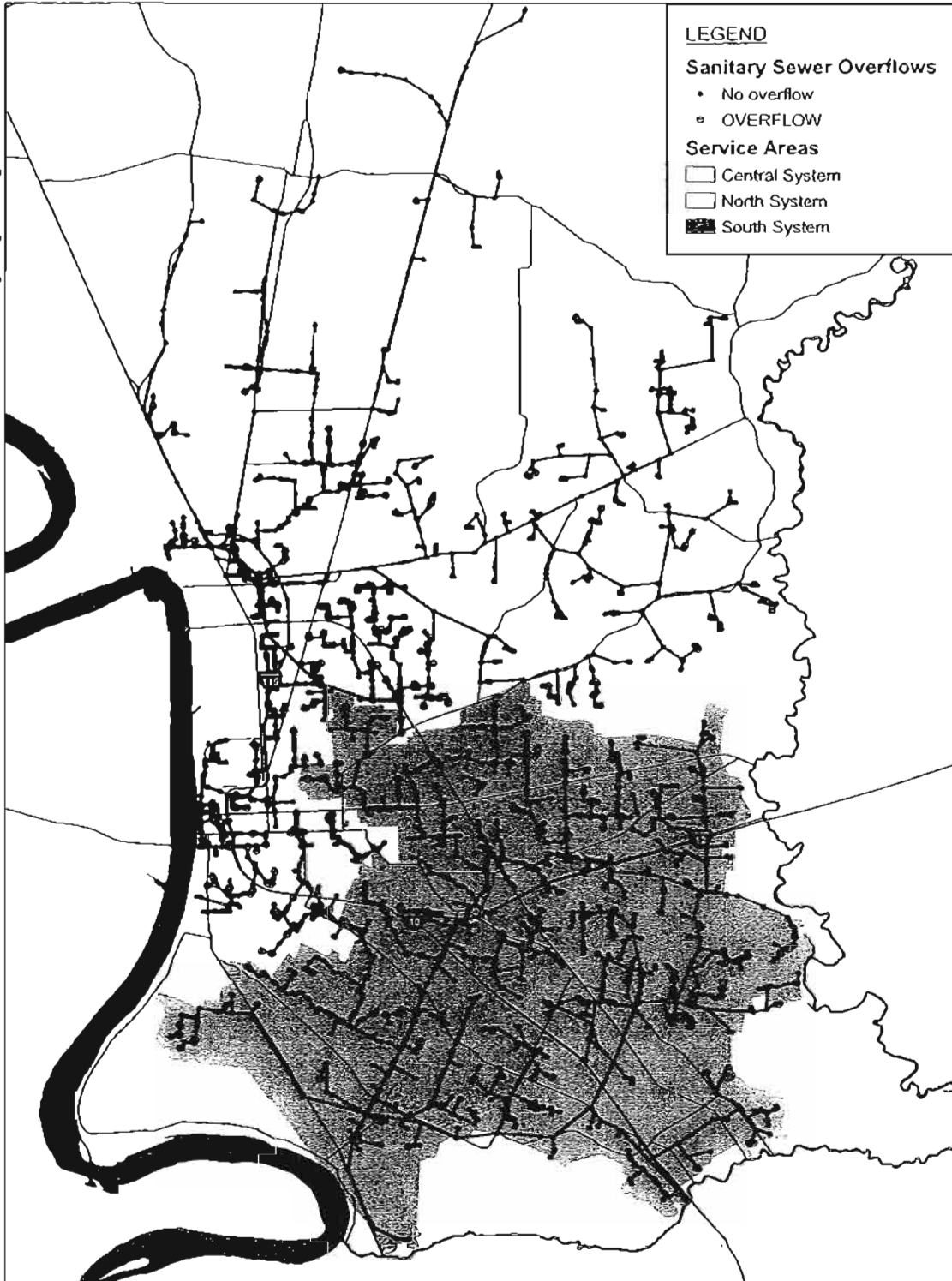

LEGEND

Sanitary Sewer Overflows

- No overflow
- OVERFLOW

Service Areas

- Central System
- North System
- ▨ South System

CDM



BATON ROUGE, LOUISIANA
EXISTING SEWER SYSTEM
LOCATION OF PREDICTED SYSTEM OVERFLOWS

FIGURE 3-1

improvements. The impacts include increased flow in portions of the conveyance system that result from pump station and pipeline capacity increases.

The City of Baton Rouge/Parish of East Baton Rouge (City/Parish) wishes to develop a solution that focuses on fixing major portions of the existing infrastructure while minimizing construction of additional new facilities or in-system storage. Therefore, the remedial action plan first looked at reducing system inflows by rehabilitating and upgrading local sewers. Then, the plan addressed remaining deficiencies by upgrading existing sewer pipes and pumping stations. Finally, the treatment plants were evaluated to assure all the flow in the system is treated according to Louisiana Pollution Discharge Elimination System (LPDES) permit requirements. The following sections discuss the various options available for developing required solutions to the system capacity problems.

3.2 Potential Solutions

A primary objective of this study is to identify wastewater collection and transmission system improvements that will remove rainfall dependent infiltration and inflow (RDII) and convey future base wastewater flows and wet-weather flows without surcharging or overflows for the design storm event. The combination of high RDII flows and increased base wastewater flows due to population growth have resulted in system surcharging and sanitary sewer overflows (SSOs) within the existing City/Parish system. High rates of RDII have been observed in many areas of the City/Parish system, and previous studies have characterized RDII as severe. Consequently, a comprehensive rehabilitation program aimed at reducing RDII and improving local system performance is a major component of the recommended improvement program. In addition, increased sewer and pumping capacity will be required to accommodate some level of RDII during wet weather as well as dry-weather flow associated with growth. Growth is projected to occur in the outer portions of the City/Parish system, particularly in the south service area.

The following sections discuss the full range of system improvements that have been considered and integrated into the recommended improvement program, including comprehensive sewer rehabilitation to reduce RDII, trunk sewer system and pump station upgrades, reduction of peak wet weather flows through flow equalization, and treatment of excess flows at the wastewater treatment plants (WWTPs). A general discussion of each of these improvement alternatives is presented herein.

3.2.1 Sewer Rehabilitation

Sewer rehabilitation is an effective means of reducing peak wet-weather flows that may cause sewer overflows. Three general sewer rehabilitation approaches that can be implemented within the City/Parish sewer system are:

- Comprehensive rehabilitation of all sewers and service laterals located both within the public right-of-way and on private property.
- Comprehensive rehabilitation of sewers located within public rights-of-way only.

- Repair of structural defects in pipes and manholes and removal of major identified inflow sources.

The first and second approaches encompass a "comprehensive rehabilitation" approach, with the only difference being the limits of rehabilitation. A comprehensive rehabilitation approach consists of rehabilitation of sewer areas that do not meet I/I control standards. The third approach is a structural rehabilitation approach, repairing only specific defects that are identified through sewer system evaluation survey (SSES) work, and is focused more on SSOs resulting from structural problems rather than RDII. This approach does not include laterals and thus is not typically an effective method of reducing RDII.

A more detailed discussion of both the comprehensive sewer rehabilitation and structural rehabilitation approaches follows.

3.2.1.1 Comprehensive Sewer Rehabilitation Techniques

Comprehensive sewer rehabilitation programs have proven effective in other municipal systems at eliminating a large percentage of RDII, and are effective at reducing both the volume of RDII and the peak flows of RDII into the system. This is evidenced by the case studies summarized in the recent American Society of Civil Engineers (ASCE) and Environmental Protection Agency (EPA) guidance manual titled "*Sanitary Sewer Overflow Solutions*" published in April 2004, comprehensive rehabilitation has resulted in reductions of infiltration and inflow from between 50 to 80 percent. While comprehensive rehabilitation is typically aimed at reducing peak RDII flows, rehabilitation can also reduce groundwater infiltration (GWI) flows by 85 to 90 percent. A reduction of GWI would be beneficial during dry weather conditions to reduce daily flows and operational costs of pumping stations and at the wastewater treatment plant. In addition to RDII and GWI reduction, design of a comprehensive rehabilitation program includes repairing structural defects and maintenance problems within the system.

A comprehensive sewer rehabilitation program consists of replacing, lining, or otherwise rehabilitating all pipe within the study area; however, this approach is cost effective because of the resulting reduction in RDII, extended system life, and other system benefits. This is particularly true in areas of the City/Parish system that have been identified as having high RDII rates based on a review of flow monitoring information and hydraulic modeling simulations.

There are several issues that must be addressed in a comprehensive rehabilitation program. For example, a comprehensive rehabilitation program including all sewer mains may not meet RDII reduction goals if a large percentage of RDII is entering through defective service laterals. Consequently, the need for private-side and public-side lateral rehabilitation must be considered as a component to this program.

Point repairs to address severe structural or maintenance problems (e.g., collapsed pipe and sags) are required prior to comprehensive sewer rehabilitation and will

differ depending on the sewer rehabilitation technique used. Rehabilitation of manholes within the system must also be considered.

Comprehensive sewer rehabilitation techniques include pipe bursting and lining. Each of these techniques is discussed below.

Pipe Bursting

Pipe bursting involves inserting a pneumatic, hydraulic, or mechanical wedge into the pipe. The wedge is then expanded in the existing pipe, fracturing the walls of the pipe



and pushing the pieces into the surrounding soil. A new pipe is jacked into the place directly behind the wedge. The new pipe is either high density polyethylene (HDPE) with welded joints or short-jointed and thick-walled with in-wall joints (joints with no bells), which facilitates installation of the new pipe from an existing manhole access. With pipe bursting, the hydraulic wedge is guided by the existing pipe and therefore, the new pipe will follow the grade of the existing pipe.

Existing sewers that are free of sags or other hydraulic problems are the most appropriate for this technique. Pipe of the same or greater diameter than the existing pipe may be installed. Prior to pipe bursting, service laterals must be open excavated and disconnected in order to avoid destroying them with the hydraulic wedge. Depending on the type of pipe bursting technology used, there is the potential to harm adjacent utilities; therefore, care must be exercised in the selection of the type of equipment to be used when other utilities are located near the sewer.

Lining

CDM's broad definition of lining includes all rehabilitation techniques where a smaller diameter pipe is inserted, installed, or constructed inside of the existing sewer pipe. A wide variety of techniques fall within this category that are generally distinguished by the type of liner used. The variations in lining techniques include slip-lining, cured-in-place lining, and fold-and-form lining. These techniques offer the advantage of requiring little or no excavation for installation, and are therefore most suitable for pipes where aboveground obstructions exist or where very deep excavation would be required to replace the pipe. Lining also allows minimal disruption to traffic where sewer lines are located within public roads. Sewers must be cleaned and obstructions such as roots or protruding service connections must be removed prior to insertion of the liner. If all obstructions cannot be removed with conventional cleaning and cutting equipment, then excavation is necessary at those specific locations.

Slip-lining

Slip-lining involves inserting a pipe of a slightly smaller diameter into the existing pipe, usually from an excavated insertion pit. The liner pipe must be flexible and is commonly made of HDPE, fiberglass, or polyvinyl chloride (PVC). Liner pipe joints

are heat-fused or gasketed, with heat-fused joints having the advantage of allowing the liner pipe to be closer in diameter to the existing pipe. The liner pipe is inserted by excavating an insertion pit at the center of the length of existing pipe. From this pit, the liner pipe may be inserted in both directions. The liner pipes are typically pulled through the sewer pipe with the assistance of a winch assembly that is installed in the adjacent manhole. Because pulling the liner pipe often causes it to elongate, the pipe must be allowed to contract to its original length before service connections and seals to manholes are made. Alternatively, the liner can be installed by pushing the liner pipe into the old pipe, using a sling or jacking assembly to avoid damage to the liner pipe.

CDM recommends that the void left between the existing pipe and the new pipe be filled with grout. If slip-lining is used without filling voids between the liner and the existing pipe with grout, less structural benefit is gained from the liner, and future loading increases to the pipe may result in failure. The annular space should be grouted in order to ensure the long-term strength of the newly lined pipe. The annular space should be at least two inches (50 mm) in order for grouting to be effective.

Once the slip-liner is in place, service connections must be made to the liner pipe. This must be performed by excavating each service connection, breaking through the outside pipe, and then making a connection to the slip-liner pipe by use of sidewall heat fusion or tapping saddles.

Cured-in-Place Lining

Cured-in-place lining (inversion lining) consists of a felt, fabric, or fiberglass lining that is impregnated with resin and becomes rigid through thermal activation (curing).

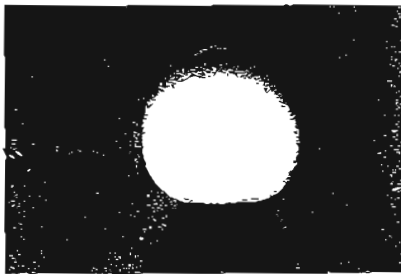

The liner typically is inserted in an inverted fashion into the existing pipe using water pressure. Once the liner is inserted, it is cured with the use of hot water or hot air that causes the liner to become rigid. The resulting liner is seamless and jointless. Service connections are made by excavation and the installation of a tapping saddle or equivalent watertight connection. Cured-in-place lining is a relatively quick method of rehabilitation and generally requires only 24 to 48 hours of bypass pumping of wastewater flows. Cured-in-place linings can be designed to handle structural loads, if necessary, where the existing pipe has structural defects or where additional loads are expected in the future.

Fold-and-Formed Pipe Lining

Fold-and-formed pipe lining is similar to slip-lining, except that the liner pipe is deformed in some manner to aid insertion into the existing pipe. Depending on the specific manufacturer, the liner pipe may be made of PVC or HDPE. One method of deforming the liner is to fold it into a "U" shape before insertion into the existing pipe. The pipe is then returned to its original circular shape using heated air or water, or using a rounded shaping device or mandrel. Ideally, there will be no void between

the existing pipe and the liner pipe after expansion of the liner pipe with the shaping device. For the "U" shape liner, the resulting pipe liner is seamless and jointless.

Most lining techniques have had very good reliability with proper installation. Slip-lining and cured-in-place lining techniques have been used extensively throughout the United States, and the fold-and-formed technique has been used throughout the country with success.

3.2.1.2 Private Lateral Rehabilitation

To achieve the desired RDII reduction as part of the City/Parish program, it is expected that rehabilitation and repairs will be required on private property in some areas. The recommended approach for the City/Parish to take in areas where RDII reduction is targeted is to begin with comprehensive rehabilitation of the public sewer system as described above, including the service laterals up to the property line. In areas where this approach does not achieve the desired level of RDII reduction or in areas where there are known significant sources of RDII on private property from system investigations, additional rehabilitation of the remaining service laterals on private property will need to be performed.

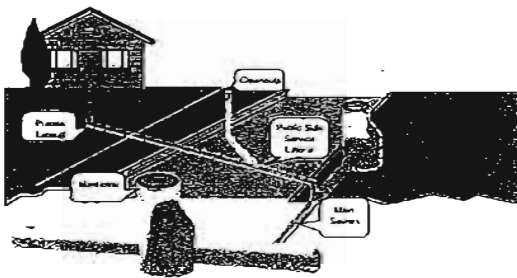

Rehabilitation of lateral sewers on private property may be accomplished using the same types of rehabilitation techniques as described previously. Trenchless techniques such as pipe-bursting are particularly applicable in areas where residents or businesses may have extensive landscaping or other surface conflicts that would make open cut excavation expensive or undesirable.

The City/Parish currently has a sewer ordinance in place that provides the authority to require customers to remove sources of extraneous flow from the sanitary sewer system and to maintain the private lateral. The ordinance creates a system for notice and an order by the City/Parish to trigger the repair. Customers who fail to do so can be subject to fine and property liens. The City/Parish has the authority to perform the repair where the private landowner fails to do so. The City/Parish is currently researching a number of approaches to assist private landowners and to streamline the program without having to use enforcement action, but such authority is available where needed. The City/Parish also has an assistance program for persons who cannot afford repairs. See <http://www.brgov.com/dept/ocd/housing/sewerweb.htm>.

Excerpts of the applicable portions of the City/Parish ordinance related to this issue follow:

Sec. 2:308. Duty of owner.

(a) It shall be the duty of all owners of improved premises which have been tied in and connected to the operating sanitary sewage system, as hereinabove provided, to maintain the service line on the premises or within a servitude in favor of the premises up to the sanitary sewerage system which has been accepted and

maintained by the city-parish. It shall also be the duty of such owners to close any opening that allows the drainage of surface water into the sanitary sewer system. It shall only be the duty of the city-parish to maintain that portion of any service line located in a right-of-way dedicated to the public.

(b) Any person who violates the provisions of subsection (a) above shall be fined not more than five hundred dollars (\$500.00) for domestic users and one thousand dollars (\$1,000.00) for nondomestic users or imprisoned for not more than thirty (30) days, or both, at the discretion of the court.

(c) Any person who violates the provisions of subsection (a) above may be subject to the following:

(1) When the director of public works, or his representative, upon evidence establishing more probably than not that the provisions of subsection (a) above have been violated, the director of public works, or his representative, shall send notice personally or by certified mail that the person who violates the provisions of subsection (a) shall begin to make efforts to remedy such violation within ten (10) days, and steadily and without delay continue such efforts to remedy such violation under the monitoring of the director of public works, or his representative. If the certified letter is not claimed or if no effort is made to remedy such violation of the provisions of subsection (a) above within ten (10) days upon receipt of the letter, or upon reasonable notice, suit shall be filed requiring the remedy of the violation of the provisions of subsection (a) above and authorizing fines up to five hundred dollars (\$500.00) a day for domestic users and one thousand dollars (\$1,000.00) a day for nondomestic users in which no efforts are made toward remedying such violation. Said suit may recover reasonable attorney's fees, court costs, court reporter's fees, and other expenses of litigation against the person who violates the provisions of subsection (a) above.

(2) Where in the perception of the director of public works, or his representative, that public health will be threatened by the delays involved in the proceeding, as provided in the above paragraph, injunctive relief shall be permitted.

(3) Where immediate action is required to avoid a threat to public health, the director of public works, or his representative, may act to remedy such violation of subsection (a) above and seek damages from the person committing the violation of subsection (a) above. Fines up to five hundred dollars (\$500.00) a day for domestic users and one thousand dollars (\$1,000.00) a day for nondomestic users until the threat to public health is abated, and costs incurred in remedying such violation of subsection (a) above may be recovered. Also, said suit may recover reasonable attorney's fees, and other expenses of litigation against the person who violates the provisions of subsection (a) above.

(4) If the director of public works, or his representative, acts to remedy such violation of subsection (a), or if the owner is an absentee or has no known mailing address, the director of public works, or his representative, shall then cause the necessary work to be done to effect compliance with the provisions of this section at the owner's expense; and the director of public works, or his representative, may have such work done either with the personnel and equipment of his department, or by means of a contract with a third person; except that if the work is done by private contract, the work shall only be done after advertisement for bids in accordance with the purchasing regulations.

(5) Upon completion of such work, the director of public works, or his representative, shall cause to be prepared and filed with the recorder of mortgages of this parish a certificate showing the cost of such work, a penalty of ten (10) percent thereof or fifty

dollars (\$50.00), whichever is greater, the name of the owner and a description of the property involved. The certificate shall operate from the date of filing as a tax lien or assessment on the property affected. This lien shall prescribe only in ten (10) years from the date of filing such certificate, may be enforced in a summary manner as other tax liens or assessments, and shall be subject to the same penalties, interest and attorney's fees.

(6) Upon the filing of this certificate, the director of public works, or his representative, in writing shall advise the director of finance and the parish attorney thereof; and the latter shall institute suit or take such other steps as may be required or necessary for the enforcement of such lien.

(City Ord. No. 4791, 10-27-82; Parish Ord. No. 5998, 10-27-82; Ord. No. 10069, § 1, 11-9-94; Ord. No. 10440, § 1, 9-13-95; Ord. No. 11568, § 1, 10-13-99)

Sec. 2:309. Violation and penalties.

(a) It shall be prohibited for anyone to create an opening into the sanitary sewer system that will allow the flow of surface water into said system, and any such opening is declared to be a nuisance detrimental to the public health and safety and as such, a misdemeanor, punishable as provided in subsection (b).

(b) Anyone who creates such an opening shall be guilty of a misdemeanor, and shall, upon conviction thereof, be punishable by a fine of not more than five hundred dollars (\$500.00) for domestic users and one thousand dollars (\$1,000.00) for nondomestic users or imprisonment for not more than thirty (30) days, or both, at the discretion of the court.

(Ord. No. 11569, § 1, 10-13-99)

The City/Parish has researched a number of private lateral rehabilitation programs across the country to determine program elements that have been effective. A key consideration of a program to address private sewer lateral rehabilitation in the State of Louisiana is that Article 7, § 14 of the Louisiana Constitution prohibits "the use of public funds, credit, property, or things of value of the state or of any political subdivision as loans, pledges, or donations to or for any private person, association, or corporation." However, there are exceptions to this prohibition, including an exception that allows "the use of public funds for programs of social welfare for the aid and support of the needy." Further, the Louisiana Attorney General provided the City/Parish with a formal opinion indicating that the City/Parish can make repairs to private property and then seek to recover the costs through its legal authority under the ordinances above. The same opinion as well as the jurisprudence also indicates that if the City/Parish is legally obligated to provide something of value, such is not contrary to the Constitution.

Thus, there are a number of potential alternatives that the City/Parish can use to accomplish private system rehabilitation both under its existing ordinances/program and under potential amendments. The City/Parish is committed to using and enhancing its existing program by improving its public education program such as through updates to websites and/or mail-outs with sewer user bills and through including additional information with the 10 day notice letters to private landowners

such as lists and contact information for certified plumbers. The City/Parish will also work with the Community Development organization to improve the process of securing financial aid under the Sewerline Assistance Program noted above.

The City/Parish is also committed to reviewing and discussing with the Metro Council for potential adoption a number of the options reviewed from other communities and options allowed under the Attorney General's opinion. Some of these potential mechanisms are discussed below.

First, as the Constitution contains an exemption to the "public purpose" doctrine for assisting needy residents, the City/Parish will consider and evaluate an amendment to the ordinances to create such an exemption. For example, public funds could pay for the repairs of residents who met a specifically defined and consistently applied criteria to determine whether they were needy. A process could be developed to create a form response to a 10 day notice letter of required repair work which could allow the recipient to certify that it meets the criteria for this exemption.

Second, the City/Parish may consider proposing to the Metro Council an amendment addressing improvements to the system for recovering the cost of work it performs. Currently, a lien is required, along with a lawsuit for collection. A potential amendment would consist of allowing the private owner to authorize the City/Parish to perform the work and then collect reimbursement through additions to that person's monthly sewer user bill, potentially even beginning at the point of receipt of the 10 day notice.

Third, the City/Parish could explore ways to use funds that are not considered to be public. For example, sewer customers could be charged "insurance" through the existing sewer user fee program on a monthly basis that would go toward a self-funded program of repairing private laterals that were found to be defective. This funding mechanism could be administered by the City/Parish or a selected trustee, but would remain as private funds in a separate pool maintained solely for the purpose of rehabilitating private laterals. Several insurance systems of this type have been adopted by other states. The City/Parish will review the efficacy of these existing programs for possible proposal and consideration by the Metro Council.

A fourth potential option involves the use of funds for which the City/Parish is legally obligated to pay. We are aware that at least two other municipalities have performed Supplemental Environmental Projects (SEPs) as part of Consent Decrees with EPA that have consisted of funding pilot programs for private sewer repair. A possibility the City/Parish may consider is proposing to resolve outstanding stipulated penalties under the Consent Decree through performance of a Supplemental Environmental Project to fund private sewer lateral repair within specified priority basins. Because the City/Parish is legally obligated to pay the stipulated penalties or to satisfy them with a SEP, such expenditure should not contravene the constitutional requirement.

A final possibility would be for the City/Parish to seek special legislation that would clarify or amend the existing Constitutional provisions so as to allow the use of public funds for the repairs of private service laterals. Because this is becoming a significant issue at the state and national levels, this special legislation may find solid support.

A summary table that contains information on private service lateral policies and programs from other communities around the country is provided in **Appendix D**. This table is presented as evidence that this issue has been and can be successfully addressed by a number of alternative means. Based on its existing authorities, the City/Parish is confident that it can successfully reduce the RDII contributions from private property to a level that meets the RDII reduction targets of the recommended plan. The adoption of additional enhancements may make these targets more easily achievable, and the City/Parish intends to evaluate these additional options. An article discussing private sewer lateral rehabilitation is also provided in **Appendix D**.

3.2.1.3 Sewer Rehabilitation Cost and RDII Reduction

Sewer rehabilitation costs vary widely depending upon the site-specific sewer conditions and the selected sewer rehabilitation approach and technique, as shown in **Table 3-1**. The costs reflect rehabilitation of 8-inch diameter sewers (which is the typical collection sewer size) and are based upon recent regional bid tabulations and manufacturer quotations.

Table 3-1
Cost Estimate for Sewer Rehabilitation

<i>Rehabilitation Approach</i>	<i>Estimated Cost (\$/LF)</i>
Comprehensive rehabilitation of all sewers within both public rights-of-way and on private property	\$90 - \$120
Comprehensive rehabilitation of all sewers located within public rights-of-way only	\$70 - \$100
Structural rehabilitation - removal of major identified inflow sources, repair of structural defects in pipes and manholes	\$10 - \$60

3.2.1.4 Structural Rehabilitation Approach

Point repairs are an important element of any sewer rehabilitation program. A point repair program will contribute to meeting the three "common" sewer rehabilitation objectives: eliminate RDII sources (limited), correct structural problems, and correct alignment and maintenance problems. Defects that are identified during SSES work that can be corrected using point repairs include:

- Replacing structurally defective pipe segments
- Repairing defective lateral connections (hammer taps)

- Removing roots from joints
- Repairing offset joints
- Repairing sags in pipes or pipe joints
- Replacing and/or repairing defective manholes and manhole casings
- Removing other major inflow sources such as storm water connections

Performing point repairs will meet the rehabilitation objectives of repairing structural defects and maintenance concerns within the system. However, it has been found that significant RDII reduction is typically not achievable through a point repair program alone. Therefore, for the City/Parish program, it is recommended that a comprehensive approach be used where RDII reduction is the primary objective. A structural rehabilitation approach may be used where localized rehabilitation is needed to correct structural or maintenance deficiencies.

The primary drawback to a point repair rehabilitation program for RDII is migration. Construction techniques using trenching and/or stone bedding for sewer pipe encourage migration by providing a path for groundwater to follow. Unless all defects within a reach of sewer are found, RDII will migrate from the location of the repaired defect to an adjacent defect. It is very difficult to find all defects within a sewer system, even if every foot of pipe is inspected by closed circuit television (CCTV). Based on past projects, it has been found that a rehabilitation program that relies on point repairs alone can result in an RDII volume reduction on the order of 0 to 25 percent, and RDII peak reduction of 0 to 10 percent. To ensure that all defects are corrected within a reach of sewer and to achieve higher levels of RDII reduction, a comprehensive rehabilitation approach must be used.

3.2.2 Trunk Sewer System Improvements

Trunk sewer system improvements can increase the hydraulic capacity of existing pipelines prone to surcharging, thereby reducing overflows associated with insufficient transmission capacity. These improvements also offer the benefit of providing additional dry-weather wastewater conveyance capacity to accommodate future growth in a service area. Trunk sewer improvement alternatives include (1) replacement or relief sewers and (2) sewer "pressurization." Each of these options is described below. Because trunk sewer system improvements will result in increased downstream wet-weather peak flows, downstream sewer system improvements (additional trunk sewer capacity, pump station upgrades, plant equalization, and plant improvements) may be required in conjunction with upstream improvements.

3.2.2.1 Replacement and Relief Sewers

Replacement or relief sewers are typically required to convey projected dry-weather flows that exceed existing trunk sewer capacity. In addition, SSOs can be eliminated

by constructing replacement or relief sewers designed with increased capacity to effectively convey peak wet-weather flows.

Relief sewers may be constructed parallel to an existing trunk sewer, or along an independent route designed to bypass areas that are hydraulically limited. Relief sewers may be designed as on-line or off-line systems. On-line relief sewers would convey both dry- and wet-weather flows. On-line relief sewers should be designed to ensure that minimum hour dry-weather flow velocities are maintained above 2.0 feet per second to prevent solids deposition and resultant odor and maintenance problems. Off-line relief sewers are only used during wet-weather conditions. Flow into off-line relief sewers can be controlled hydraulically via a fixed weir or junction box, or mechanically using a power-operated gate or similar device. In addition to providing necessary wet-weather conveyance capacity, relief sewers can increase sewer maintenance flexibility by allowing one sewer line to be removed from service (without bypass pumping).

Replacement sewers may be preferable to relief sewer construction if the existing trunk sewer is in poor condition or if construction easement limitations and/or land acquisition requirements preclude cost-effective relief sewer construction. However, replacement sewer material costs are typically higher than relief sewer costs since the replacement sewers need to be sized larger to offer equivalent capacity as parallel sewers (existing and relief sewer). In addition, the need to maintain sewer flow during replacement sewer construction may necessitate special construction procedures (e.g., bypass pumping) that can significantly increase costs.

3.2.2.2 Sewer Pressurization

Sewer pressurization can increase the hydraulic and storage capacity of existing trunk sewers (and eliminate localized overflows) by increasing the hydraulic grade line in the reach until the sewer is surcharged. Typically, manholes along the reach are either sealed or raised to allow the sewer to be surcharged during peak wet-weather conditions without creating an overflow situation.

Sewer pressurization is not a conventional improvement, and potential impacts should be carefully considered on a case-by-case basis. The structural integrity and design of the sewer in question must be carefully checked to ensure that it can withstand the anticipated increase in pressure. It is equally important that the hydraulics be carefully considered to ensure that the higher water level does not cause sewage backups into homes or other connected systems, and that the backwater does not reduce upstream carrying capacity. It should be noted that if manhole inverts are formed to convey flow from one-half of the pipe depth, then pressurization may not increase hydraulic capacity because of significant entrance and exit losses. To achieve this benefit the channel must be reconstructed for conveyance of flows that will fill the pipe. If these criteria are met, sewer pressurization can be one of the most cost-effective means of eliminating localized overflows and increasing hydraulic carrying capacity and in-line storage.

3.2.3 Pump Station Improvements

The sewer system model was evaluated with sewer system line improvements to reduce the R-values; however, the model indicates overflows will occur even with sewer system rehabilitation if additional capacity improvements are not made. Capacity upgrades to the City/Parish existing pump stations or the construction of new pump stations will be required to convey wet-weather flows and to prevent overflows upstream of the pump station. The model indicates most pump station capacity improvements of less than 12 million gallons per day (MGD), with a large percentage requiring upgrade of less than 1 MGD. In the South service area, the model indicates several pump stations require significant capacity increase.

There were also a number of pump stations included in the model that could not overcome the system head required to allow the pump stations to pump into the system. It is difficult to assess the improvements required to allow all the pumps stations to operate; therefore, detailed field investigation of each pump station is required prior to determining the specific improvements required for each pump station. Improvements may require minor adjustments, or may require pump, motor or impeller replacement.

3.2.4 Flow Equalization

Flow equalization facilities offer a means of reducing or eliminating wet-weather overflows by storing peak flows in excess of the sewer capacity. Flow equalization can be effective in reducing localized overflows, as well as upstream and downstream overflows (by reducing the hydraulic grade line elevation upstream, and by reducing downstream peak flow rates). Flow equalization can be constructed within the sewer system (in-system) or at pump stations and wastewater treatment plants. Flow equalization basins sited at plants can also be used for dry-weather diurnal equalization to dampen daily flow fluctuations and improve treatment performance.

Flow equalization storage can be designed and operated either as on-line or off-line facilities, as discussed below.

3.2.4.1 On-Line Flow Equalization

With on-line flow equalization facilities, flow is continuously routed through the system (during both dry- and wet-weather), and storage is reserved for wet-weather events. On-line flow equalization can be achieved by replacing a portion of an existing sewer with a larger sized conduit, or by constructing a parallel conduit to provide additional storage capacity. Flow into and out of the on-line flow equalization system is by gravity, and wet-weather flow equalization can be regulated by the downstream hydraulic grade line or by a physical control device. Alternative control devices include rate-of-flow control valves, regulators, orifices, and inflatable dams. The volume of flow equalization available from on-line facilities is proportional to the length of the structure; and therefore, correction of large overflows may necessitate construction of long conduits. Odor control in flow equalization facilities is an issue that must be considered.

3.2.4.2 Off-Line Flow Equalization

Typical off-line flow equalization facilities include equalization basins. Flow equalization basins typically consist of lagoons, tanks (below-ground or above-ground), and box culverts sized to store peak wet-weather flows that cannot be accommodated by the sewer system. A flow diversion chamber or pump station is required to divert peak flows from the sewer to the flow equalization tank. It is good design and operating practice to segment the tank into multiple cells and fill the tank one cell at a time. This approach minimizes the tank area to be cleaned after the wet-weather event, and can expedite tank draining by gravity. The basins can be covered and provided with odor control systems to reduce public nuisance potential. Tank mixing systems are also frequently provided (mixers, blowers, pumps) to keep solids in suspension and minimize clean-up and odor potential.

3.3 Wastewater Treatment Plant Evaluation

As part of the model verification and development of the Revised Remedial Action Plan (RMAP2), the three wastewater treatment plants were evaluated based upon peak flows projected to reach the plants and historical impact from wet weather events.

3.3.1 Results of Hydraulic Modeling Related to the WWTPs

Hydraulic modeling results for peak flows at each of the wastewater treatment plants are shown below. The current peak 1-hour design capacity for each treatment plant along with the expected peak 1-hour flows for each treatment plant following program completion are shown in Table 3-2, below.

*Table 3-2
Treatment Plant Capacity and Expected Peak Flow*

<i>Treatment Plant</i>	<i>Current Peak Hour Design Capacity (MGD)</i>	<i>Peak Hour Flow Expected (MGD)</i>
North WWTP	130	125
Central WWTP	65	62
South WWTP	120	273

The peak flows predicted by the model for the North WWTP and Central WWTP are slightly less than the plants' current treatment capacities; therefore, the two plants have adequate treatment capacity. The flows predicted for the South WWTP are significantly above the capacity of the plant and cannot be managed through pump station and flow control.

Flow hydrographs for each treatment plant are presented below. These hydrographs clearly illustrate the wet-weather flow impacts at the South WWTP.

North WWTP Hydrograph

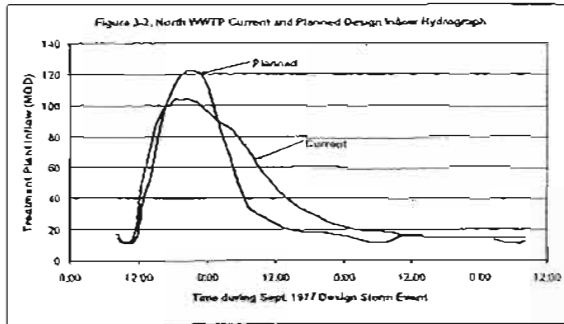

Central WWTP Hydrograph

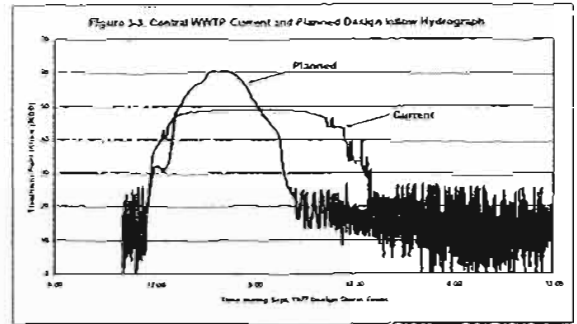

South WWTP Hydrograph

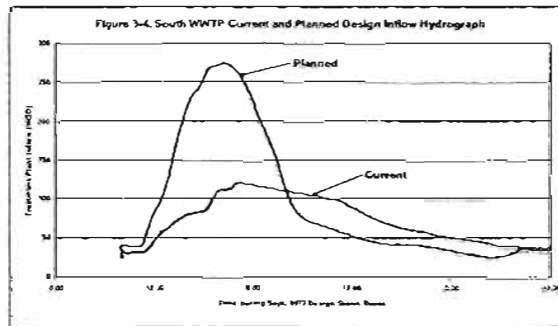

3.3.2 WWTP Effluent Quality

The six (6) charts below show the 5-day biochemical oxygen demand (BOD₅) and total suspended solids (TSS) concentrations in milligram per liter (mg/l) leaving each wastewater treatment plant for the years 2003 through May of 2005.

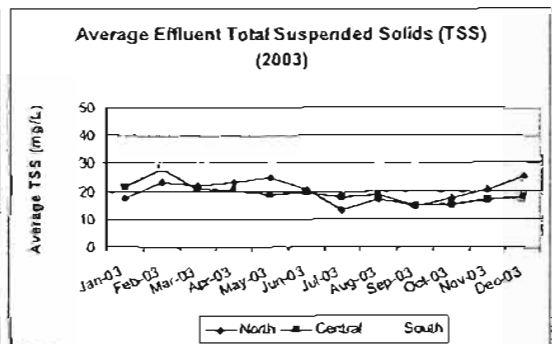
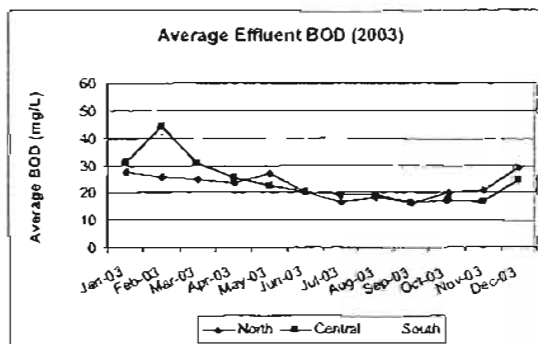

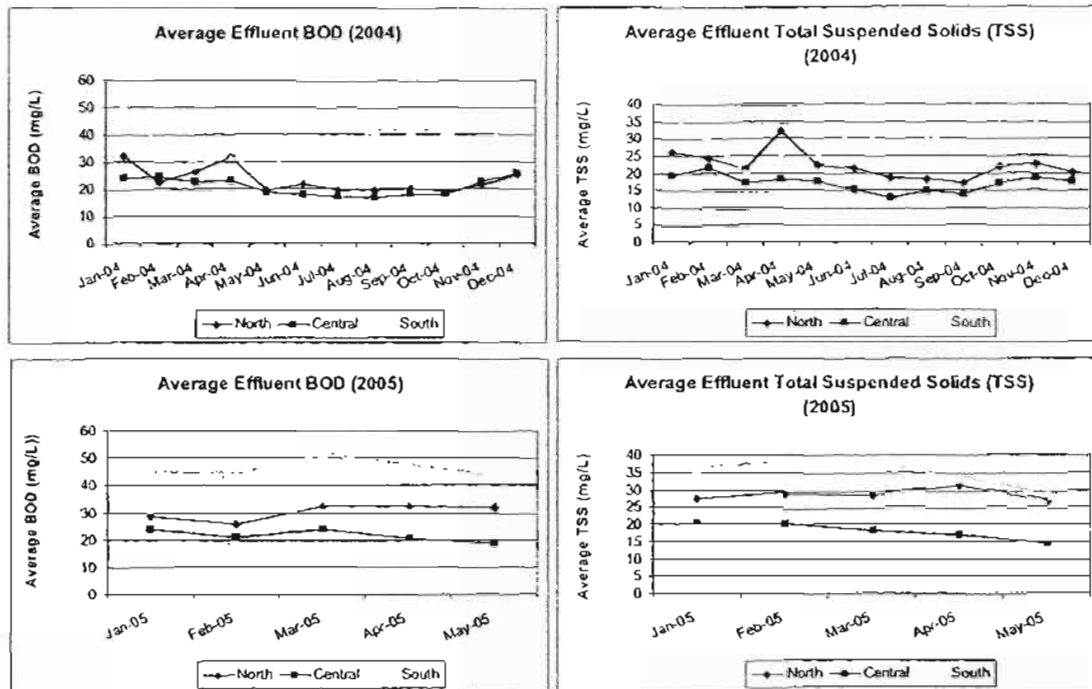

The Louisiana Pollution Discharge Elimination System (LPDES) permit limits for the 30-day average for 5-day biochemical oxygen demand (BOD₅) and total suspended solids (TSS) is 30 milligrams per liter (mg/l). The one week average for BOD₅ and TSS is 45 mg/l. The effluent quality data shows that the North WWTP and Central WWTP have consistently met their LPDES permit discharge limitations. However, the South WWTP continues to be in violation of its discharge permit for BOD₅ and TSS parameters.

Since the flows to the South WWTP under this plan will be increased, the plant was evaluated as part of this project to determine what could be done to enable the plant to handle peak flow conditions and to meet its discharge permit requirements.

3.3.2.1 Evaluation of South WWTP

On July 6, 2005 representatives from CDM met with wastewater treatment plant operations staff and toured the South WWTP. The following areas of the plant were listed by plant personnel as problem areas.

- **Bar Screens** - Inadequate bar screens are causing damage and downtime to all downstream equipment (i.e., grit removal equipment, primary clarifier equipment, trickling filters and sludge digesters).
- **Grit Removal** – The interior walls of the grit basin have structurally deteriorated from hydrogen sulfide (H₂S) corrosion. The basins are undersized for the flows they currently receive. The grit classification equipment is worn and the air headers and electrical wires are badly corroded.

- *Influent and Primary Effluent Control* – The flow into the plant is erratic and causes “spikes” of flow through the plant. The South WWTP receives flow from two separate systems, the South gravity system (SCSD) and the South pressure system (SSTN). At these two systems peak during wet-weather events, the plant receives considerable flow increases. These “spikes” of flow to and through the plant cause operational problems such as sludge pop-ups in the clarifiers. The spikes also damage equipment such as the primary clarifiers and trickling filter rotary distributors.
- *Primary Clarifiers* – Due to inadequate screening, Primary Clarifiers 1 and 2 get damaged from rags and other debris that hangs up on the equipment. Basins 3 through 6 are badly worn from grit and rags. Staff has problems obtaining replacement parts.
- *Trickling Filters* – There is limited recirculation available for the trickling filters. The trickling filters are sources of snails, which cause problems to downstream equipment. The trickling filter media gets plugged with debris and grit. Spikes in flow cause erratic treatment.
- *Secondary Clarifiers* – The secondary clarifiers are loaded with snails, which plug sludge lines and create inadequate capacity for sludge removal.

All of the above problems have a direct or indirect affect on overall performance of the South WWTP and should be addressed as part of any recommended improvements at this plant. Modifications to correct these operational issues will enhance the ability of the plant to operate within LPDES permit discharge limits.

Section 4

Improvement Plan

Using the system model described in Section 3, input from City of Baton Rouge/Parish of East Baton Rouge (City/Parish) operations and engineering staff, and an alternatives evaluation process, a revised sewer system improvements program was developed for the North, Central, and South wastewater treatment plant service areas. The alternatives evaluation included an iterative process of simulating the rainfall dependent infiltration and inflow (RDII) reduction benefits of various levels of comprehensive sewer rehabilitation in each of the service areas. The required system capacity and treatment upgrades were determined to control overflows for the design condition for each rehabilitation level. Through this iterative process, the best balance of comprehensive sewer rehabilitation and other system capacity upgrades was determined to meet the City/Parish system performance and cost-effectiveness objectives.

The recommended program strategy is to conduct comprehensive rehabilitation of the sewer system in all areas where the RDII rate currently exceeds 10 percent of the rainfall volume (i.e., the system R value exceeds 10 percent). This will result in significant reductions in wet-weather flows throughout the City/Parish system, thus improving system performance and controlling system overflows and house back-ups. In addition, the comprehensive rehabilitation program will provide substantial additional benefits in terms of reduced operation and maintenance costs as well as improved structural integrity.

The recommended improvements program includes three categories of improvements. The rehabilitation in each of the basins with R values in excess of 10 percent is considered part of the Category 1 improvements, which also includes minor pump station modifications needed to boost their pumping head (i.e., new impellers, larger motors, piping modifications).

Sewer and pump station improvement plans were devised to resolve all remaining conveyance deficiencies in each basin. The pump station and conveyance system improvements include capacity increases to the stations and piping. The pump station and conveyance system improvements are referred to as Category 2 improvements.

The models of the improved collection systems were also used to develop predicted hydrographs of flows to the treatment plants during the design storm condition once the improvements are in place. Improvements to provide flow equalization and wastewater treatment enhancements are referred to as Category 3.

4.1 Category 1: Comprehensive Sewer Basin Rehabilitation and Pump Station Upgrades

Based upon sewer system model results and flow monitoring, numerous basins within the Baton Rouge system require comprehensive rehabilitation. The basins identified through the system model are scheduled for rehabilitation based upon the

modeled R-values. The implementation schedule and preliminary opinion of probable construction cost is discussed in Section 5.

The first group of basins scheduled for rehabilitation are those with the highest existing R-values. Figures 4-1, 4-2, and 4-3 show the basins with high R-values for each service area and scheduled for comprehensive rehabilitation. The Central area R-values indicate the sewer lines in this area are generally in worse condition than other areas of the City's system. A greater portion of the Central system requires rehabilitation than other systems, likely due to the age of the system and service connections. Cross-connections may also be more likely in the older, congested area. The South system is generally in significantly better condition than the other systems; hence a lower percentage of the system requires rehabilitation.

Category 1 also provides for pump station inspection and mechanical improvements at select pump station to allow for head increase. Figures 4-4, 4-5, and 4-6 show the pump stations that require mechanical improvements to allow adequate pumping into the system. These improvements include assessing and potentially making mechanical upgrades to 43 pump stations in the North CSD area, three pump stations in the Central CSD area, and 41 pump stations in the South SCD/STN area. The assessment of the pump stations will determine specific improvements required to allow each pump station to operate against the system head. Improvements may include replacement of impellers, motors, pumps, and/or piping and will be determined for each station during design.

4.2 Category 2: Pump Station and Transmission/Conveyance System Improvements

The system model was used to identify pump stations and conveyance lines where capacity is not adequate for the peak wastewater flows. Category 2 provides for pump station and conveyance system upgrades in capacity. Figures 4-4, 4-5, and 4-6 show pump stations requiring capacity increases. A more detailed listing of the pump station and pipelines requiring capacity increases are provided in the Revised Second Remedial Action Plan as provided in Appendix B. The projects are generally discussed below.

The Category 2 improvements are identified by service area below.

North CSD/STN Area

In the North CSD/STN area, minor capacity upgrades are required at 16 pump stations. There are no significant increases in pump station capacity projected to be required in the North area. The capacity increases required are generally less than 2 millions gallons per day (MGD). Pump Station 241 requires an increase of 12.5 MGD, which is the largest increase in the service area.

Pipeline capacity improvements include replacement of approximately 37,000 linear feet (LF) of replacement gravity sewer, installation of approximately 84,000 LF of new

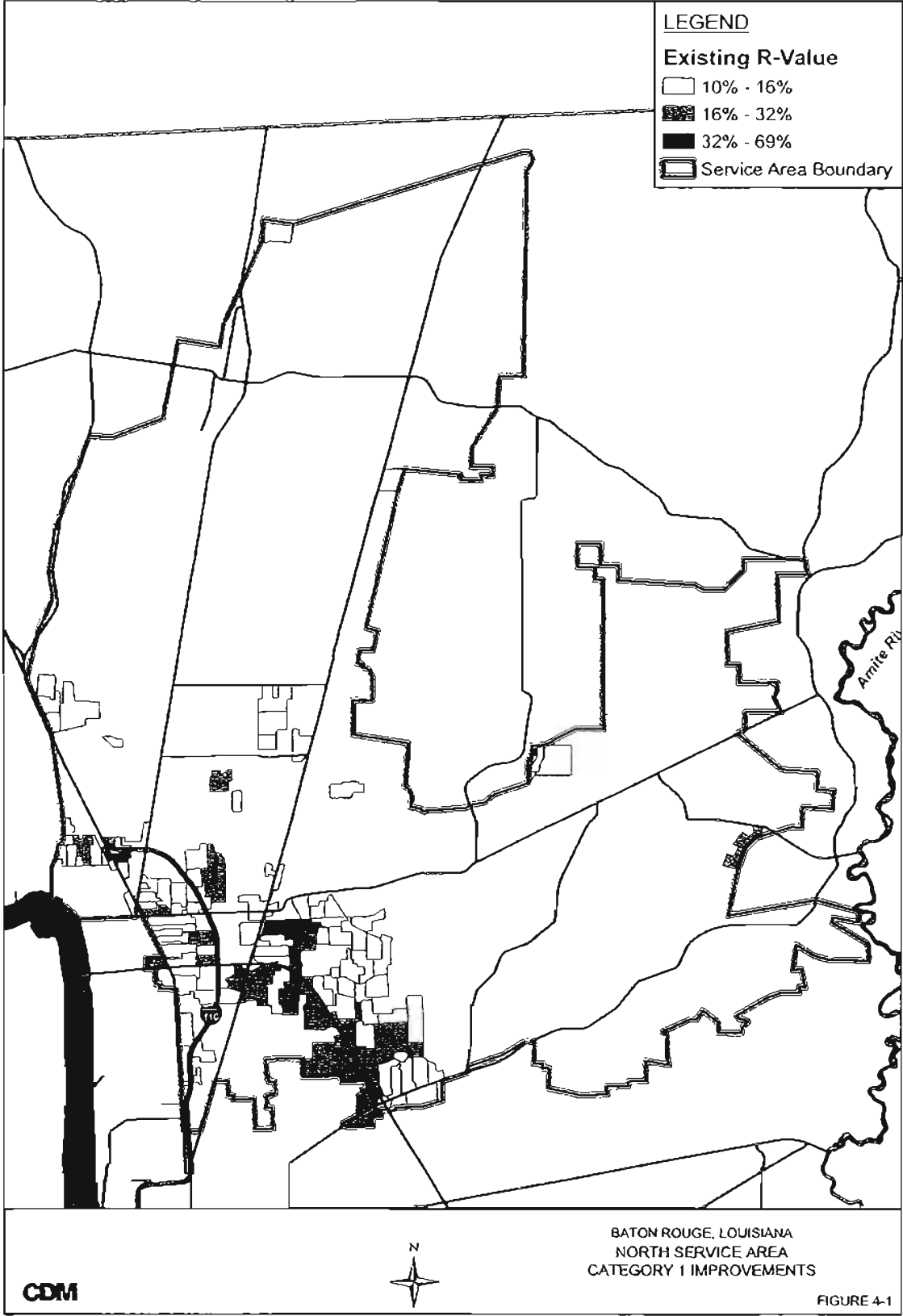

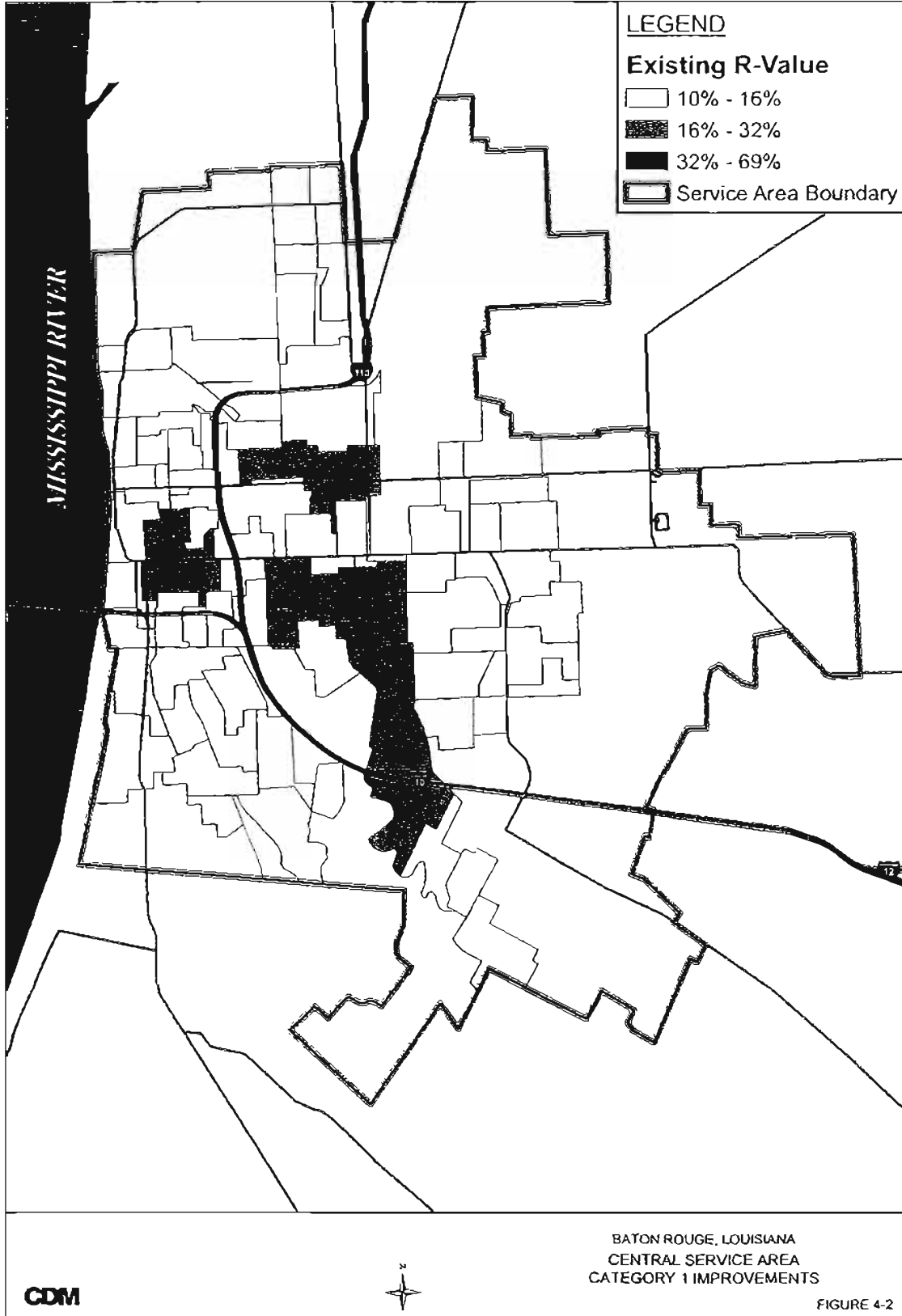



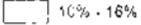
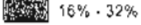
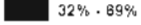

LEGEND

Existing R-Value

-  10% - 16%
-  16% - 32%
-  32% - 89%
-  Service Area Boundary



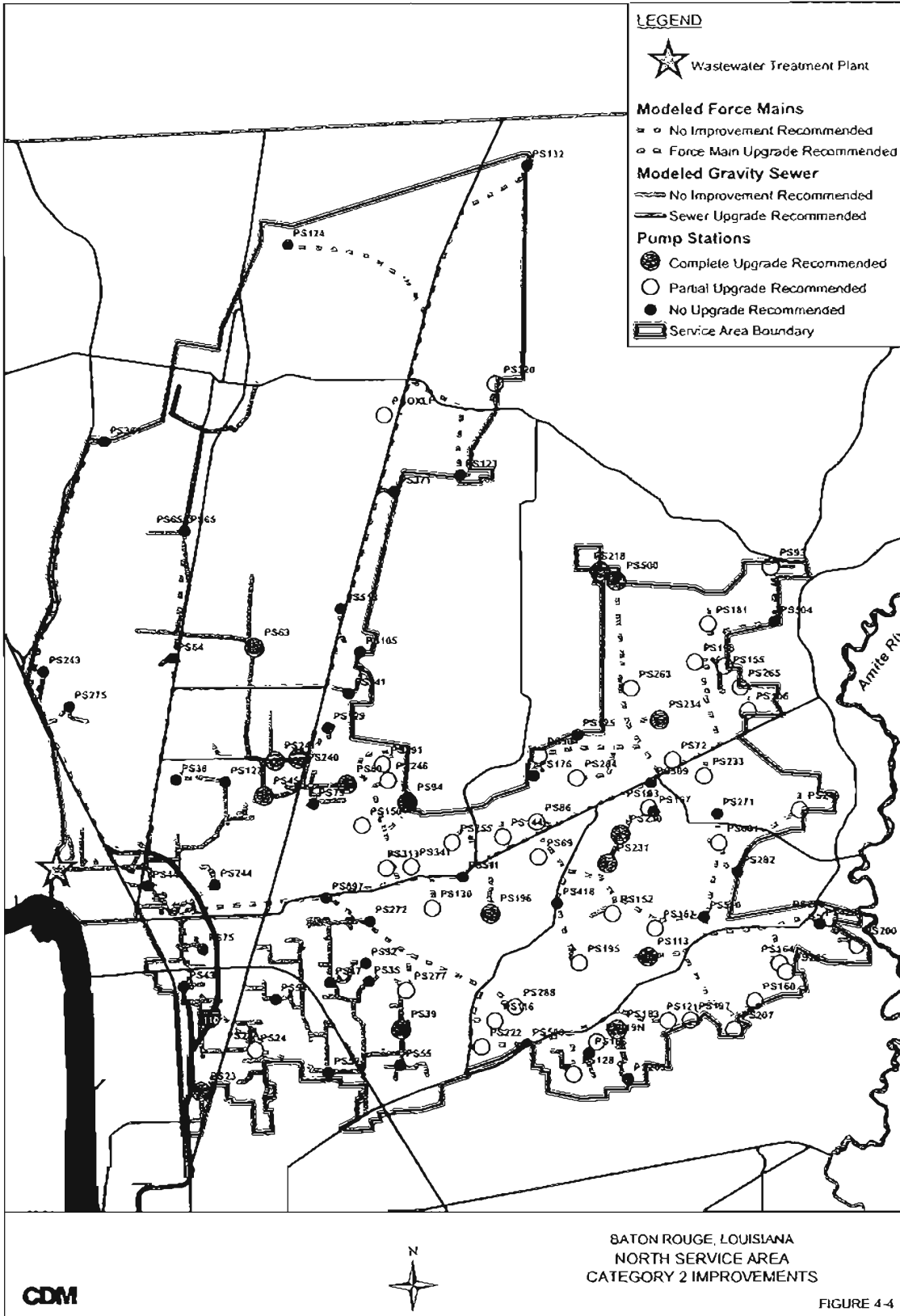

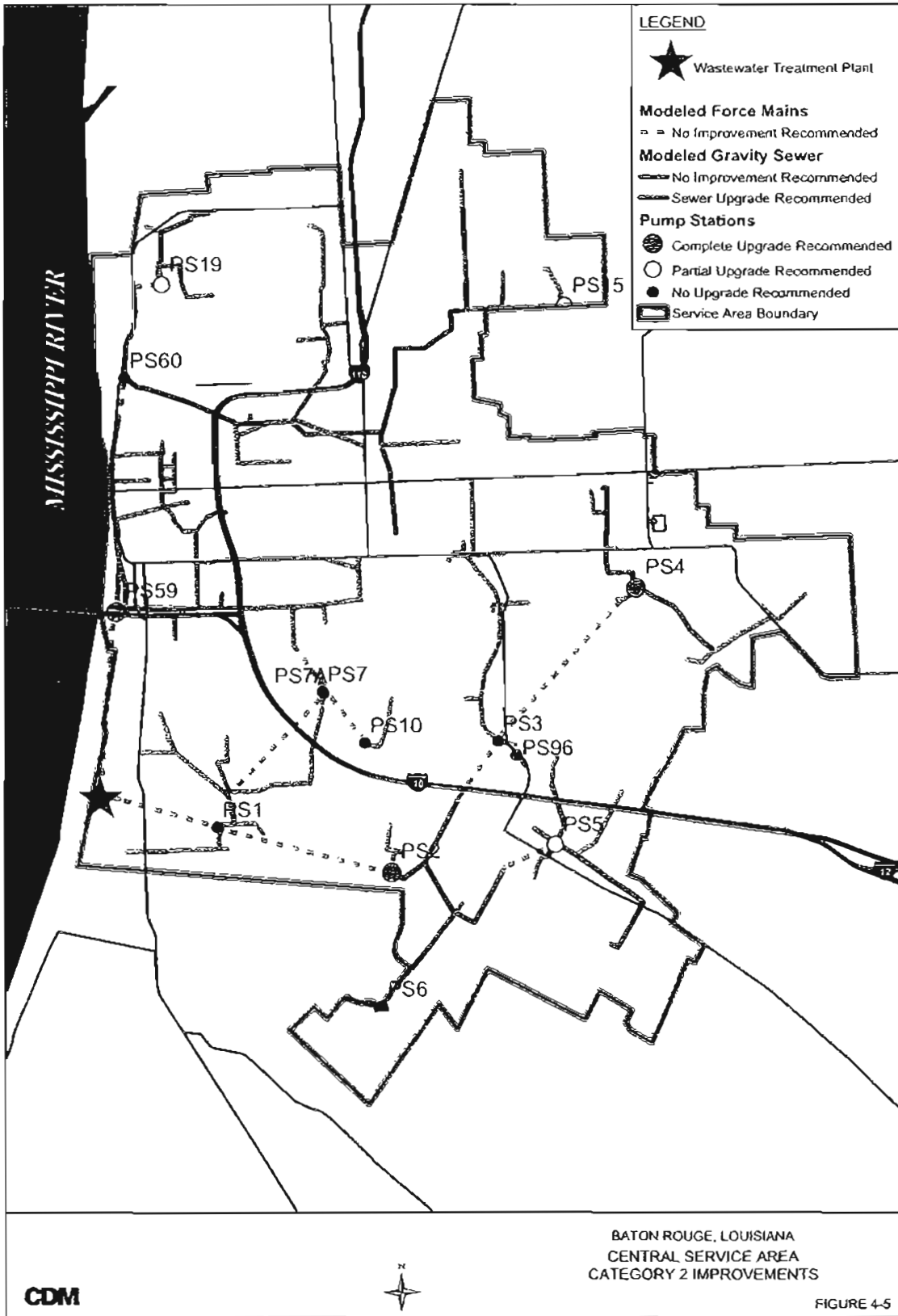

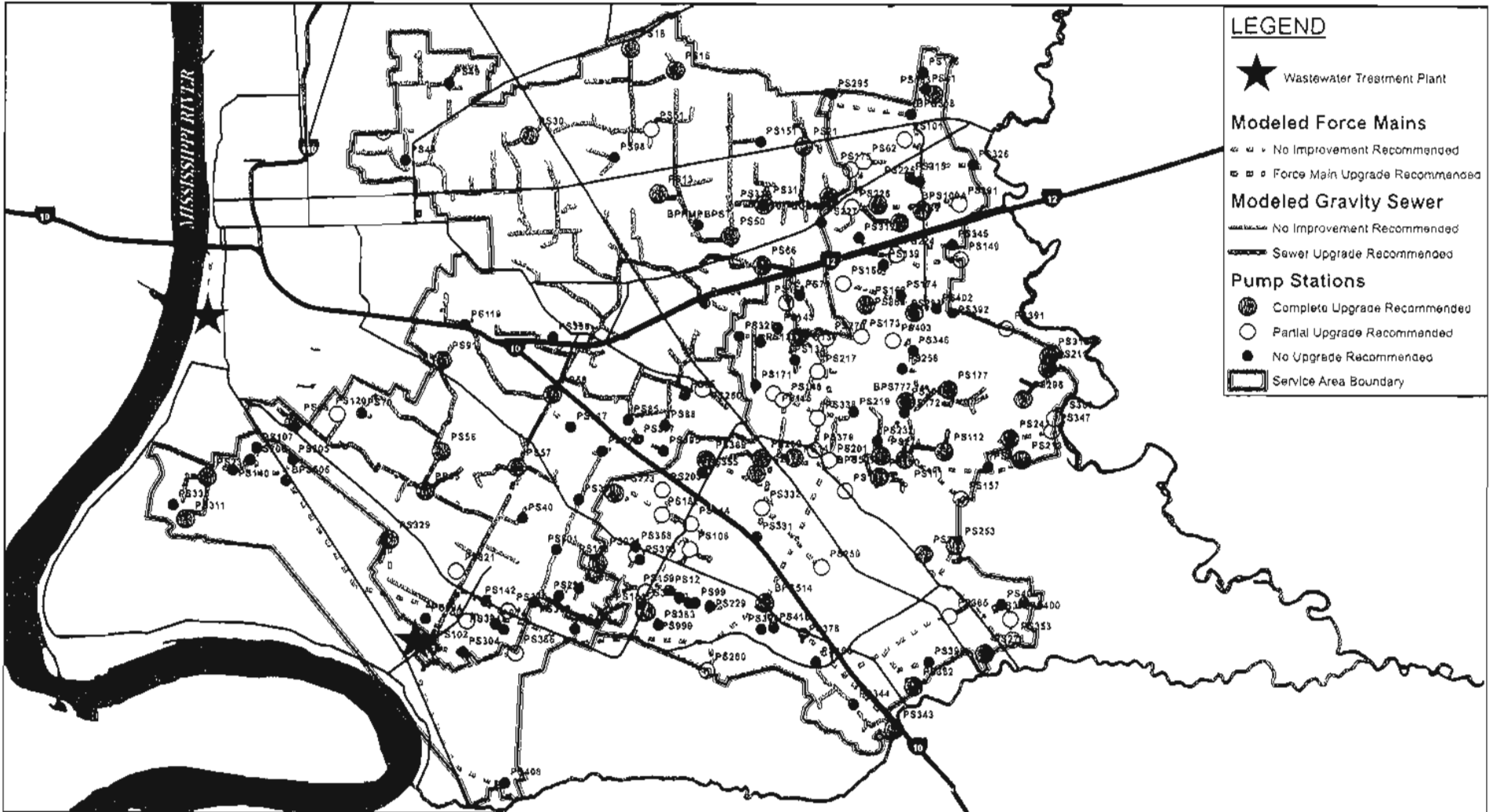

LEGEND

- ★ Wastewater Treatment Plant
- Modeled Force Mains**
 - No Improvement Recommended
 - ▬ Force Main Upgrade Recommended
- Modeled Gravity Sewer**
 - No Improvement Recommended
 - ▬ Sewer Upgrade Recommended
- Pump Stations**
 - Complete Upgrade Recommended
 - Partial Upgrade Recommended
 - No Upgrade Recommended
- ▭ Service Area Boundary

CDM



BATON ROUGE, LOUISIANA
 SOUTH SERVICE AREA
 CATEGORY 2 IMPROVEMENTS

FIGURE 4-6

parallel gravity sewer, approximately 51,000 LF of replacement force main, and 2,700 LF of parallel force main.

Central CSD Area

In the Central CSD area, capacity upgrades are required at three pump stations. The largest upgrade required based upon model results is at Pump Station 2. This pump station will require a capacity increase of approximately 17 MGD. Improvements to obtain this increased capacity will be determined during design.

Pipeline capacity improvements include replacement of approximately 22,000 LF of replacement gravity sewer and installation of approximately 38,000 LF of new parallel gravity sewer. Based upon model results, no new force main based upon capacity needs is required in this service area.

South CSD/STN Area

In the South CSD/STN area, capacity upgrades are required at 35 pump stations. The largest upgrades required based upon model results are at Pump Station 57, Pump Station 58, and Pump Station 514. Pump Station 57 requires an increase in capacity of 76 MGD. Pump Station 58 requires an increase in capacity of 56 MGD, and Pump Station 514 requires an increase in capacity of 52 MGD. This significant capacity increase will likely require construction of a new pump station or significant increase to the existing pump station wet well and pump/pipe systems.

Pipeline capacity improvements include replacement of approximately 126,000 LF of replacement gravity sewer, installation of approximately 174,000 LF of new parallel gravity sewer, approximately 26,000 LF of replacement force main, and 7,000 LF of parallel force main.

4.3 Category 3: Flow Equalization and Wastewater Treatment Improvements

The conveyance improvements described in the previous sections will decrease peak flows to the North and Central Wastewater Treatment Plants (WWTP) and increase peak flow to the South WWTP. Therefore, flow equalization and/or treatment capacity improvements will be necessary to address these larger peak flows at the South WWTP. The peak flows predicted by the model for the North WWTP and Central WWTP are slightly less than the plants' current peak treatment capacities.

Sewer rehabilitation will actually decrease dry weather flows in the basins because infiltration of groundwater will be reduced. No redirection of flows from one treatment plant service area to another was found to be beneficial during the development of the program.

Based upon the predicted increase in flow to the South WWTP and the historical performance of the treatment plant, the following improvements to the treatment plant are recommended.

- **New Headworks and Flow Equalization Basin** – Peak flows to the South WWTP from the gravity collection system (SCSD) and the force main system (SSTN) will be 273 MGD. If the South WWTP is upgraded to a peak capacity of 200 MGD, flow

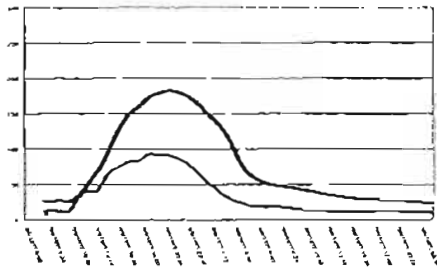

South WWTP Hydrograph

equalization facilities with the ability to accommodate the remaining 73 MGD are required. The hydrograph shows the time duration of the 73 mgd and through integration it has been determined that the volume needed to store this peak flow would be 19 million gallons. The construction of a new headworks facility with screening, grit removal facilities and influent pumping in the vicinity of the proposed 19 million gallon equalization basin is required. With a new headworks facility, the two poorly functioning headworks facilities at the South WWTP can be

eliminated and the spikes in flow through the plant can be eliminated. Several locations for the new headworks and flow equalization facilities are being evaluated and are shown on Figure 4-7. All three locations are near the existing South WWTP. However, the Alternative 1 location offers an advantage in that the existing influent line to the South WWTP traverses this property.

- **Upgrade the South WWTP to a 200 mgd Activated Sludge WWTP** – Since it is not practical or economical to add more trickling filters (biotowers) to the South WWTP, abandoning the trickling filters and constructing a new activated sludge process is recommended. Construction of an activated sludge process has numerous advantages; several of which are: 1) achieves effluent quality better than 30/30, 2) consistently meets Louisiana Pollution Discharge Elimination System (NPDES) limits, 3) enables elimination of primary effluent pump stations, 4) enables abandonment of chlorination facilities for disinfection and allows use of ultraviolet light for disinfection, 5) helps to control odors, 6) helps with aesthetics in the surrounding quickly developing section of town, and 7) eliminates current problems with snails.



Figure 4-7
Alternative Locations for the New South WWTP Headworks and
Flow Equalization Facility

Section 5

Implementation Plan

5.1 Requirements

The Consent Decree entered into by the Environmental Protection Agency (EPA), the Louisiana Department of Environmental Quality (LDEQ) and the City of Baton Rouge/Parish of East Baton Rouge (City/Parish) requires the Second Remedial Measures Action Plan (RMAP2) to provide specific information related to system improvements to reduce overflows and comply with the requirements of the Consent Decree. Specifically, the Consent Decree states the following:

“In the Second RMAP, the City/Parish shall provide a detailed description of the selected remedial measure and shall specify a schedule for beginning and completing construction of each element of the selected remedial measure not addressed in the First RMAP. The Second RMAP shall also set forth a process for evaluating and providing the personnel and training that will be required to successfully implement the selected remedial measure. The Second RMAP shall also provide an estimate of the cost of the selected remedial measure and a detailed description of how the City/Parish will fund the remedial measure to be implemented.”

The revised RMAP2 is provided as **Appendix B** to this report and is summarized in this section. Each of the required elements is addressed.

5.2 Construction Sequence and Schedule

Prior to commencing design on any facilities required to implement the recommended plan and modified RMAP2, approval is required from EPA as well as the City/Parish government. Per the Consent Decree, EPA has up to 120 days for approval of the revised plan. Following approval of the plan, there is a 45 day period for public comment for the proposed amended Consent Decree. After EPA review and approval, LDEQ has to place a public notice for 45 days. After the 45 day public comment period is complete, the Court should approve the revised Consent Decree. Upon approval of the revised plan, site analysis, design and construction will commence for projects required to implement the recommended plan. The EPA and City/Parish approval process is noted in the schedule shown in **Figure 5-1**. A detailed schedule is provided in **Appendix E**.

A project schedule has been developed that reflected the design, bidding, construction, and start-up of the projects included in Category 1, 2 and 3. As required by the Consent Decree, the schedule reflects a completely operational system by January 2015, with milestones noted for completion of individual projects. The construction projects included in the schedule allow the City/Parish to comply with the requirements of the Consent Decree for reduction of sewer system overflows (SSO) within the collection area and for the discharge from the wastewater treatment plants to be within permit limits.

Figure 5-1
Program Implementation Schedule

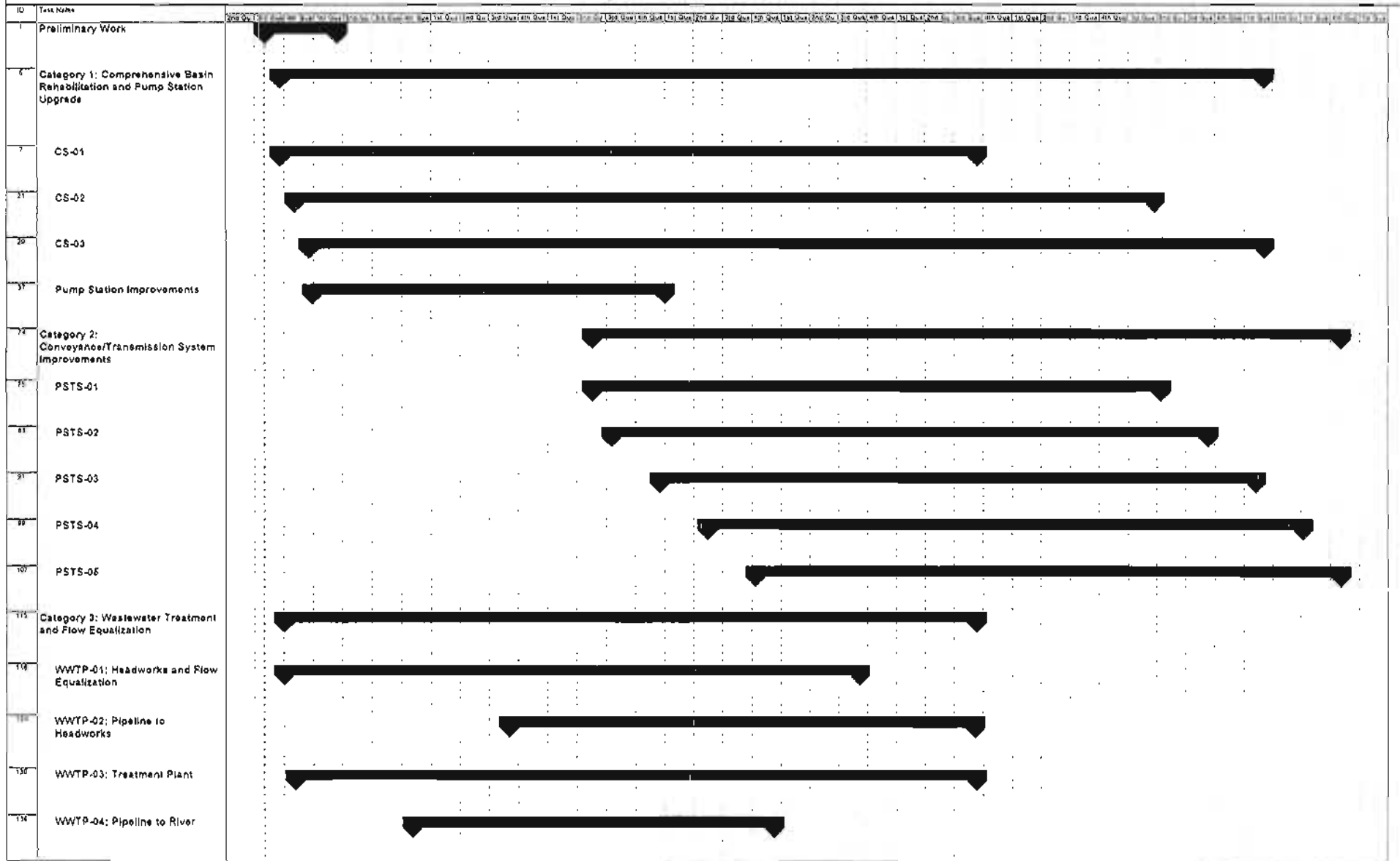

Float time has been added to each project activity to allow for unforeseen design or construction events and for agency review. Generally, 120 days have been allotted for bidding and award of each project, between 60 days and 120 days have been allotted for start-up of the collection system improvements and 120 days have been allotted for start-up of the pump stations and treatment plant. Additional float time is built into the end of each project in the start-up/float time activity.

The City/Parish has an on-going street improvement program. A number of the sewers selected for rehabilitation, replacement, or parallel including new pipeline and parallel lines are adjacent to or directly under street scheduled for improvements. The program must consider the street improvements projects (the *Green Light Plan*) when developing a final schedule for implementation, and there are significant opportunities to save costs by coordinating the City/Parish street improvements and sewer improvements programs.

The schedule developed for each Category is discussed below.

5.2.1 Category 1: Comprehensive Sewer Basin Rehabilitation and Pump Station Improvements

The Category 1 improvements are those improvements identified for each sewer sub-basin including pipeline rehabilitation and mechanical improvements to pump stations. The pipeline improvements include repair and/or replacement of local gravity sewer lines and manholes as well as rehabilitation of service lateral connections to the main line. The improvements also include rehabilitation from the main line connection point to the property line and installation of clean-outs near the property line. Once rehabilitation of pipelines located within the public right-of-way is complete, post-construction flow monitoring will be conducted to confirm the reduction in inflow and infiltration has been adequate to achieve an R-value of 2 percent for the basin. In the event that a basin R-value is not reduced to 2 percent, private side lateral rehabilitation will be implemented as discussed in Section 3.2.1.

Pump Station Head Increase

Eighty-seven pump stations were identified in the model as requiring an increase in head, likely due to pumping against another pump station in the conveyance system. For these pump stations, 120 days have been allotted for investigation of the pump stations and determination of specific improvements. The improvements may include replacement of impellers, pumps or piping to allow for increased head. These pump stations do not require capacity increases based on their design capacity. The field investigation is scheduled to commence immediately upon approval by EPA of Revised RMAP2. The bidding is scheduled between June 2006 and July 2007. Construction for each project is scheduled for 365 days, with 90 days provided for start-up services and float time. The projects will be fully operational by December 2008.

Collection System Improvements

The collection system rehabilitation has been divided into multiple projects. The rehabilitation includes the manholes and laterals along the pipe route and replacement or upsize of pipe within the basin being rehabilitated. The projects are intended to include the collection pipeline within each basin, with larger conveyance system projects included in Category 2 work.

Each rehabilitation area will be inspected by closed circuit television (CCTV) and manhole inspection prior to design. This inspection will be used to determine the condition of the pipeline and manholes within the basin and will serve as the basis of design for the remaining portion of the basin. The basin delineation will be consistent with that defined in the model; however, each project will consist of more than one basin. The projects have been separated to generate a total length per bid package group of up to 150,000 linear feet, with the assumption that each contractor crew can rehabilitate approximately 40,000 linear feet of pipe per year. While contractors can typically rehabilitate sewers at a higher rate than this, this assumption will provide some contingency and float time in the proposed project schedule. It is recommended that the projects will generally be bid based upon rehabilitation projects totaling between \$3 million and \$6 million per bid package.

Field work is scheduled to commence immediately, with a project ready to advertise within 3 months of start of field work. The schedule includes extended bidding to provide for multiple projects. It is anticipated more than one project will be under construction during most of the consent decree duration.

The Category 1 construction is scheduled for completion by August, 2013. The comprehensive rehabilitation will fully functional by March 2014. The limitation for this schedule is the ability of the contractors and the City/Parish to bid projects at this rapid pace.

5.2.2 Category 2: Pump Station and Transmission/Conveyance System Improvements

The Category 2 improvements include repair and/or replacement of the main conveyance system. The conveyance system includes the larger diameter gravity lines, force mains, pump stations, and booster stations. These improvements were identified through the model as: 1) pipes that have limited capacity and cause surcharging and potential overflows upstream, or; 2) new pipelines that are required to convey the wastewater.

These improvements are generally split into pipe line projects and pump station projects. It is likely different contractors will bid the pump station and pipeline projects. The pipeline projects are force main or large diameter gravity replacement or parallel lines and are not associated with collection system basin work (discussed in Section 5.2.1). The pump station capacity increases are generally significant enough to warrant new pump stations or increases in wet well capacity and are considered complex construction projects.

The implementation schedule for the capacity increase projects includes time for property acquisition and zoning for new pump stations sites and pipeline servitude, design, and staggered bidding between June 2010 and June 2012. Completion of construction is scheduled for July 2014, with an additional 120 days for start-up and float. The projects will be fully operational by November 2014.

5.2.3 Category 3: Flow Equalization and Wastewater Treatment Improvements

The treatment plant improvements have been split into four projects. Project WWTP-01 consists of construction of the new 273 million gallon per day (MGD) headworks facility, 19 million gallon flow equalization facility, and 200 MGD pump station serving the South Wastewater Treatment Plant (WWTP). This project includes a stub-out for connection to the facility. Project WWTP-02 consists of construction of the piping required to connect the new headworks with the existing gravity and transmission influent pipes and the pipe required to connect the new headworks with the South WWTP. Project WWTP-03 consists of the construction of the new activated sludge facilities and demolition of existing facilities at the South WWTP. Project WWTP-04 consists of the construction of the new pipeline from the South WWTP to the Mississippi River. This pipeline is required because of the increase in treatment plant capacity at the South WWTP. The projects and proposed schedule are summarized below.

Project WWTP-01: New 273 MGD Headworks and Flow Equalization

This project includes construction of a new 273 MGD headworks including: screening and grit removal, an electrical building, a new 200 MGD pump station with six pumps with variable speed drives and motors, a 19 million gallon below ground flow equalization facility, and odor control facilities.

Prior to design and land acquisition, 90 days are provided for development of a site analysis and selection. Following site selection, 90 days are provided for land acquisition by the City/Parish. Design is scheduled for 545 days and includes permitting and float time. The project is schedule for construction to start in May 2007 and to be complete in May 2010. The new facilities will be fully functional by September 2010.

Project WWTP-02: Pipeline Connection to New Headworks

This project provides for the construction of new pipeline connecting the existing pipeline from the force main side and gravity side of the South WWTP to the new headworks. The surveying is scheduled for 90 days, and design and property acquisition are scheduled for 365 days. The construction is scheduled for 540 days, with start-up scheduled for 120 days. The project construction is scheduled to commence in August 2008 and final start-up complete by September 2011. The project will be fully operational upon completion of the headworks (discussed above) and connection to the South WWTP.

Project WWTP-03: South WWTP Improvements – Activated Sludge Process

The South WWTP improvements provide for conversion of the treatment process to activated sludge, demolition of portions of the existing treatment system, and other process improvements, enabling the treatment plant to comply with the Louisiana Pollution Discharge Elimination System (LPDES) permit limitations. The schedule for this project provides for 545 days for design commencing in January 2006. Construction is scheduled to start in May 2007 and the system will be fully functional by September 2011.

Project WWTP-04: Pipeline to the Mississippi River

With the addition of treatment plant flow to the South WWTP, additional capacity is required in the discharge line. A parallel pipeline to the existing discharge point is provided in this project. The schedule includes adequate time for permitting and agency coordination. Surveying is scheduled for 90 days, with an additional 300 days provided for permitting and property acquisition. Construction is scheduled to commence in April 2008 and be complete in August 2009. The project will be fully operational by December 2009.

5.3 Estimated Design and Construction Cost

The cost estimate for the recommended improvements includes administration, design, contingency, bidding, and construction costs and includes an allowance for normal inflation. The costs do not include land acquisition required for easements or for new facilities. The opinion of probable construction cost for each of the categories of improvements is discussed below. Additional cost information is provided in Appendix F.

5.3.1 Category 1: Comprehensive Sewer Basin Rehabilitation and Pump Station Upgrades

Category 1 is the cost associated with basin rehabilitation, which includes local gravity collection system pipe lining and bursting, manhole rehabilitation, and rehabilitation of active service lateral connections to the main line. The projects have been separated to generate bid packages valued at between \$3 million and \$6 million. This cost includes manhole and public-side lateral rehabilitation. Additional costs for service lateral rehabilitation has been included if private-side lateral rehabilitation is required to reduce the basin R-values. The private-side lateral rehabilitation allowance includes administration of the private lateral program to provide potential funding for needy residents and seed money for any potential loan program. The preliminary opinion of probable construction cost for the comprehensive sewer rehabilitation in Category 1 is \$170 million to rehabilitate approximately 350 miles of sewer lines and \$30 million for pump station improvements. The rehabilitation costs are based upon a unit price ranging between \$80 and \$90 per linear foot of pipe rehabilitated and \$5 to \$10 per foot of pipe for engineering and field work. This is consistent with the information presented in Table 3-1 for comprehensive rehabilitation including manholes and sewer lateral rehabilitation.

Eighty-seven pump stations were identified in the model as requiring an increase in head, likely due to pumping against another pump station in the conveyance system. It is anticipated not all pump stations will require improvements once detailed field investigation has been completed. These improvements are divided into seven construction contracts valued between \$3 and \$6 million per project for a preliminary opinion of probable construction cost of \$30 million. The total preliminary opinion of probable construction cost for Category 1 improvements is approximately \$200 million.

5.3.2 Category 2: Pump Station and Transmission/Conveyance System Improvements

The Category 2 improvements include capacity increases including pipeline replacement or parallel lines and pump station capacity increases. These improvements are considered part of the revised RMAP2. The cost estimates developed for these improvements are discussed below.

Pump Station or Pipe Line Capacity Increase:

These improvements are generally split into pipe line projects and pump station projects. The pipeline project contracts are split into bid projects generally valued between \$3 million and \$12 million. The pump station capacity increases are generally significant enough to warrant new pump stations or increases in wet well capacity and are considered complex construction projects. Several of these pump station construction contracts will be over \$20 million each.

The replacement or parallel pipeline costs are based upon unit prices for new pipe including installation and roadway crossings. All unit costs include engineering and contingency. The unit cost of the installed pipe ranges from \$5.50 to \$20 per inch diameter per foot. The price variation is due to depth of installation and material for pipe. The cost does not include land acquisition. The total Category 2 preliminary opinion of probable construction cost is \$232 million.

5.3.3 Category 3: Flow Equalization and Wastewater Treatment Improvements

Category 3 costs include costs associated with treatment and flow equalization improvements. As previously discussed, no treatment plant improvements are required at the North WWTP or Central WWTP in order to meet the wet-weather requirements of the Consent Decree. The treatment plant improvements required to meet the Consent Decree and manage the wet weather at the South WWTP are construction of a new aeration basin/activated sludge tank with six cells and two new final clarifiers, demolition of the existing trickling filters. In addition, the cost includes purchase of land for construction of a new headworks facility, connection of the existing influent plant flow to this facility, and demolition of the existing headworks facilities for the gravity and force main sides of the treatment plant. The preliminary opinion of probable construction cost for Category 3 is \$68 million and

includes administration, construction, engineering, and contingency. This cost does not include land acquisition.

5.4 Operation and Maintenance (O&M)

Implementation of the revised RMAP2 program will have a number of implications related to operation and maintenance (O&M) costs to the City/Parish. To evaluate these impacts, CDM obtained the detailed City/Parish line item wastewater budget and used this budget to determine how O&M costs would be expected to change upon implementation of the improvements program.

O&M cost savings are expected in wastewater treatment, pumping, and sewer system maintenance as a result of infiltration reductions that will be achieved by the comprehensive rehabilitation program. Based on previous flow monitoring and modeling done in the City/Parish system, a significant portion of the sewer system has average groundwater infiltration rates of 3,000 gallons per foot per year or greater. It is planned that comprehensive rehabilitation would remove 80 percent of this groundwater infiltration in the rehabilitated areas – past studies have shown groundwater infiltration reductions of between 75 to 90 percent have been achieved through comprehensive rehabilitation, as discussed earlier in this report.

5.4.1 Wastewater Treatment Plant O&M Costs

Based on the City/Parish budget, treatment plant power and chemical costs average approximately \$0.18 per 1,000 gallons of wastewater treated. Considering the projected reduction in groundwater infiltration that is treated at the wastewater treatment plants as a result of comprehensive rehabilitation, a savings in treatment costs of approximately \$890,000 per year is expected at the completion of the RMAP2 rehabilitation program. This cost savings is the result of reduced groundwater infiltration. Additional treatment costs savings can be realized from the modifications to the South WWTP process and equipment.

The addition of blowers at the plant because of the conversion to an activate sludge process are expected to add approximately \$500,000 in annual power costs. The addition of ultraviolet disinfection will also add approximately \$300,000 in annual operating costs; however, this cost will be offset by a savings of approximately \$400,000 in chlorine, sulfur dioxide and caustic costs that will no longer be incurred.

In addition, the existing two headworks facilities require extensive maintenance and operate poorly. Considerable grit and rags continue to pass through the headworks and impact downstream equipment. Maintenance to remove rags, repair damaged equipment due to grit, and remove snails from sludge pumping and piping is required. More frequent cleaning of the clarifiers and digesters also results from poor headworks performance. Electrical savings will be realized by removing the gravity side influent pump station from service. In addition, the two primary effluent pump stations will no longer be in service and will provide additional electrical savings. The

total projected savings due to process and equipment modification at the South WWTP is an additional \$700,000.

The net decrease in wastewater treatment plant O&M cost is expected to be approximately \$1.6 million once the RMAP2 program is complete.

5.4.2 Pumping O&M Costs

Based on current costs, system pumping costs approximately \$0.06 per 1,000 gallons of wastewater that reaches the treatment plant. Infiltration reduction from comprehensive rehabilitation is projected to reduce pumping costs in the system by approximately \$275,000 annually. While there will be a number of pump stations that are upgraded and/or reconstructed as part of the improvements program, the total rate of pumping and amount of power used will not change significantly except as reduced by the comprehensive rehabilitation.

In fact, there are a number of design improvements that can be made to the pump stations during the upgrades that will have an overall benefit in terms of reduced power usage. It is often possible to realize significant energy savings through proper pump selection and operation. Variable speed pumping is an effective method of minimizing the hydraulic velocities in the piping systems (while maintaining adequate velocities to keep solids in suspension), which in turn reduces friction losses and typically saves energy, especially in systems with long force mains. Energy savings can also be realized by proper pump selection and operation of pumps near their best efficiency point.

5.4.3 Collection System O&M Costs

Additional O&M savings will be achieved as a result of a decrease in overflow and stoppage response and a decrease in the frequency of cleaning needed for the rehabilitated pipes. At the completion of the RMAP2 comprehensive rehabilitation program, it is anticipated that the City/Parish costs for emergency point repairs of structural failures will be decreased from its current \$2,000,000 annual cost to approximately \$1,100,000 (a \$900,000 savings) given that much of the oldest sewers will be included in the rehabilitation program. In addition, it is anticipated that the responsive (emergency) maintenance costs will be reduced by approximately \$460,000 based on a reduced cleaning frequency that will be required in the rehabilitated areas.

5.4.4 Total Operation and Maintenance Savings

Based on this analysis, CDM estimates the following changes in the annual City/Parish operation and maintenance costs as a result of implementing the revised RMAP2 program:

Wastewater Treatment Plant O&M:	\$1.6 million savings
Pumping O&M:	\$0.3 million savings
Collection System O&M:	<u>\$1.3 million savings</u>
TOTAL O&M:	\$3.2 million savings

5.5 Program Costs

Table 5-1 presents a summary of the SSO construction costs for the Category 1, 2 and 3 projects. The total cost of the program is \$500 million and is based on the annual costs for each year of construction. The inflation index of 2.282 percent was used to calculate the present value of the construction costs as of 2005, or a total present value of approximately \$448.6 million for the period of 2005 through 2014.

**Table 5-1
Projected Cash Flow Requirements**

	2005	2006	2007	2008	2009	2010	2011	2012	2013	2014	Total
Category 1: Collection System Basin Rehabilitation											
SSO Collection System	1,700,000	21,140,000	31,510,000	68,928,100	47,443,000	18,411,600	5,500,000	2,427,300	1,340,000	700,000	199,100,000
Category 2: Pump Station and Transmission/Conveyance System Improvements											
Pump Station & Transmission	500,000	500,000	-	-	5,342,900	18,393,500	60,065,000	84,967,000	49,338,000	14,620,000	233,726,400
Category 3: Treatment Plant and Flow Equalization											
WWTP & Flow Equalization Basin	-	3,176,000	11,864,000	20,188,000	19,956,000	9,634,000	3,182,000				68,000,000
Total Annual Cost	2,200,000	24,816,000	43,374,000	89,116,100	72,741,900	46,439,100	68,747,000	87,394,300	50,678,000	15,320,000	500,826,400

TABLE OF CONTENTS

I.	<u>BACKGROUND</u>	1
II.	<u>JURISDICTION AND VENUE</u>	3
III.	<u>PARTIES</u>	4
IV.	<u>BINDING EFFECT</u>	4
V.	<u>OBJECTIVES</u>	5
VI.	<u>DEFINITIONS</u>	6
VII.	<u>COMPLIANCE WITH CLEAN WATER ACT</u>	9
VIII.	<u>REMEDIAL MEASURES-ELIMINATION OF CROSS CONNECTIONS</u>	9
IX.	<u>REMEDIAL MEASURES-PREVENTIVE MAINTENANCE PROGRAM PLANS</u>	10
X.	<u>REMEDIAL MEASURES-SANITARY SEWER OVERFLOW RESPONSE PLAN</u>	13
XI.	<u>REMEDIAL MEASURES-REPORTING OF UNAUTHORIZED DISCHARGES</u>	14
XII.	<u>REMEDIAL MEASURES-COLLECTION SYSTEM REMEDIAL PROGRAM</u>	15
XIII.	<u>REMEDIAL MEASURES-TREATMENT FACILITY ASSESSMENT</u>	20
XIV.	<u>REMEDIAL MEASURES-ENVIRONMENTAL RESULTS MONITORING PLAN</u>	20
XV.	<u>OUTREACH AND PUBLIC AWARENESS</u>	21
XVI.	<u>INTERIM EFFLUENT LIMITS</u>	21
XVII.	<u>REVIEW OF SUBMITTALS</u>	21
XVIII.	<u>REPORTING</u>	27
XIX.	<u>CIVIL PENALTY</u>	29

XX. <u>SUPPLEMENTAL ENVIRONMENTAL PROJECTS</u>	31
XXI. <u>STIPULATED PENALTIES</u>	34
XXII. <u>FORCE MAJEURE</u>	42
XXIII. <u>RETENTION OF JURISDICTION</u>	44
XXIV. <u>DISPUTE RESOLUTION</u>	45
XXV. <u>RIGHT OF ENTRY</u>	50
XXVI. <u>NOT A PERMIT/COMPLIANCE WITH OTHER STATUTES/ REGULATIONS</u>	51
XXVII. <u>FAILURE OF COMPLIANCE</u>	52
XXVIII. <u>NON-WAIVER PROVISIONS</u>	52
XXIX. <u>COVENANT NOT TO SUE BY THE UNITED STATES AND THE STATE OF LOUISIANA</u>	54
XXX. <u>ENDANGERMENT</u>	55
XXXI. <u>COSTS OF SUIT</u>	56
XXXII. <u>RECORD KEEPING</u>	56
XXXIII. <u>FORM OF NOTICE</u>	57
XXXIV. <u>MODIFICATION</u>	58
XXXV. <u>CONTINGENT LIABILITY OF STATE OF LOUISIANA</u>	59
XXXVI. <u>PUBLIC COMMENT AND ENTRY</u>	59
XXXVII. <u>THE 1988 CONSENT DECREE</u>	60
XXXVIII. <u>TERMINATION</u>	60
XXXIX. <u>SIGNATORIES</u>	61

ATTACHMENTS TO THE CONSENT DECREE

- Exhibit A. Sanitary Sewer Overflow Response Plan
- Exhibit B. Map Depicting the Primary Features of collection System Remedial Action Program Alternative 1
- Exhibit C. Map Depicting the Primary Features of collection System Remedial Action Program Alternative 3
- Exhibit D. Map Depicting the Primary Features of collection System Remedial Action Program Alternative 4
- Exhibit E. Map Depicting the Primary Features of collection System Remedial Action Program Alternative 7
- Exhibit F. First Remedial Action Plan
- Exhibit G. Environmental Results Monitoring Plan
- Exhibit H. Outreach and Public Awareness Plan
- Exhibit I. Quarterly and Annual Report Format
- Exhibit J. Supplemental Environmental Project Plan Requirements
- Exhibit K. Revised Second Remedial Action Plan

I. **BACKGROUND**

A. The City of Baton Rouge, Louisiana and the Parish of East Baton Rouge, Louisiana (collectively “the City/Parish”) jointly own and operate three waste water treatment plants known as the North Waste Treatment (“the North plant”) located at 55 Mills Avenue, in East Baton Rouge Parish; the South Waste Treatment plant (“the South plant”) located at 2850 Gardere Lane, in East Baton Rouge Parish; and the Central Waste Treatment plant (“the Central plant”) located at 2443 River Road, in East Baton Rouge Parish, Louisiana.

B. On March 3, 1988, the United States filed United States v. Baton Rouge, No. 88-191A (M.D. La.) alleging civil claims for violations of the Clean Water Act (“CWA”), 33 U.S.C. § 1251 et seq., at the North, Central, and South plants. On April 26, 1988, the United States amended its Complaint to add the Parish of East Baton Rouge as a Defendant.

C. On December 23, 1988, a Modified Consent Decree (“the 1988 Consent Decree”) was entered settling the claims alleged in United States v. Baton Rouge, No. 88-191A (M.D. La.). Pursuant to the 1988 Consent Decree, the City/Parish consolidated most of its wastewater treatments plants into the North, Central, and South plants and made certain improvements to those plants. The 1988 Consent Decree continues in effect until the Date of Entry of this Consent Decree and, after that date, is terminated and superceded by this Consent Decree.

D. The State of Louisiana is a plaintiff in this action and is joined as a party under Section 309(e) of the Act, 33 U.S.C. § 1319(e). Whenever a municipality is a party to a civil action brought by the United States under section 309, the Act requires the State

in which the municipality is located to be joined as a party. In addition, on August 27, 1996 and pursuant to CWA Section 402, 33 U.S.C. § 1342, EPA granted to the State of Louisiana authority to administer its own permit program for discharges into navigable waters within Louisiana.

E. The United States and the State of Louisiana file the present civil action against the City/Parish seeking injunctive relief and civil penalties pursuant to Clean Water Act ("CWA") Sections 301 and 309, 33 U.S.C. §§ 1311 and 1319, for violations of the CWA and National Pollution Discharge Elimination System (NPDES)/Louisiana Pollution Discharge Elimination System ("LPDES") permits issued to the City/Parish for its sewage treatment plants. The violations alleged in the Complaint are:

i. Violation of NPDES/LPDES permit requirements which require the permittee to reduce the amount of biochemical oxygen demand (BOD) and total suspended solids ("TSS") such that the thirty (30) day average amount of BOD and TSS in the waste water discharged from the North, Central, and South plants is at least eighty-five percent (85%) less than the amount of BOD and TSS in the sewage entering the plant. This requirement is known as the "Eight-Five Percent Rule;"

Deleted: NPDES

ii. Violation of CWA Section 301, 33 U.S.C. § 1311, by discharging untreated sewage to navigable waters from the North, Central, and South plant sewage collection systems. Such overflows are often referred to as "sanitary sewer overflows" or "SSOs;"

iii. Violation of NPDES/LPDES permit requirements related to operation and maintenance by maintaining the North, Central, and South plant

Deleted: NPDES

sewage collection systems in a condition such that blockages and other failures in the sewage lines caused SSOs; and

iv. Violation of CWA Section 301 U.S.C. § 1311, by the Parish of East Baton Rouge by failing to obtain an NPDES/LPDES permit for discharges from the North, Central, and South plants.

Deleted: NPDES

F. Neither the City of Baton Rouge nor the Parish of East Baton Rouge is aware of any laws of the State of Louisiana which prevent the City of Baton Rouge or the Parish of East Baton Rouge from raising revenues needed to comply with the requirements of this Consent Decree.

G. The United States, the State of Louisiana, the City of Baton Rouge, and the Parish of East Baton Rouge have determined that a modification of the original Consent Decree that was entered on March 14, 2001, is desirable.

H. The United States, the State of Louisiana, the City of Baton Rouge, and the Parish of East Baton Rouge ("collectively "the Parties") recognize, and the Court by entering this Modified Consent Decree finds, that this Modified Consent Decree has been negotiated by the Parties in good faith, that implementation of this Modified Consent Decree will allow the City/Parish of come into compliance with the requirements of the CWA and regulations enacted pursuant to the CWA, that entry of this Modified Consent Decree will avoid complicated litigation between the Parties, and that this Modified Consent Decree is fair, reasonable, and in the public interest.

Deleted: ¶

NOW THEREFORE, it is hereby ORDERED, ADJUDGED and DECREED as follows:

II. JURISDICTION AND VENUE

1. This Court has jurisdiction over the subject matter of this action pursuant to CWA Section 309, 33 U.S.C. § 1319, and 28 U.S.C. §§ 1331, 1345, 1355, and 1367.

2. the Complaint states claims upon which relief may be granted against the City/Parish under Section 309 of the Clean Water Act, 33 U.S.C. § 1319, for injunctive relief and civil penalties.

3. Venue is proper in this judicial district pursuant to CWA Section 309, 33 U.S.C. § 1319, and 28 U.S.C. § 1391 because this is the district in which the City/Parish is located and the district in which the violations occurred.

III. PARTIES

4. Plaintiff, the United States of America (“United States”), is acting at the request and on behalf of the Administrator of the United States Environmental Protection Agency.

5. Plaintiff, the State of Louisiana (the State”), is a person within the meaning of CWA Sections 502(5) and 505, 33 U.S.C. §§ 1362(5) and 1367.

6. Defendant, the City of Baton Rouge is a political subdivision created by the State of Louisiana, and a municipality within the meaning of CWA Section 502(4), 33 U.S.C. § 1362(4).

7. Defendant, the City/Parish of East Baton Rouge is a political subdivision created by the State of Louisiana, and a municipality within the meaning of CWA Section 502(4), 33 U.S.C. § 1362(4).

IV. BINDING EFFECT

8. The provisions of this Consent Decree shall apply to and be binding on the Parties, their officers, directors, employees, agents, servants, successors and assigns, and

all persons, firms and corporations in active concert or participation with the Parties and/or the Parties' officers, directors, agents, employees, servants, successors and assigns.

9. The City/Parish shall give written notice of this Consent Decree to any person or entity to whom the City/Parish transfers ownership or operation of the North, Central, or South Plants and/or the sewage collection systems for those plants, and the City/Parish shall provide a copy of this Consent Decree to any such person or entity. The City/Parish shall notify the State and the United States in writing at least twenty-one (21) days prior to any such transfer

10. The City/Parish shall provide a copy of this Consent Decree to each engineering, consulting and contracting firm to be retained to perform Work within ten (10) days of after entry of this Consent Decree or, for Work commenced after such date, upon execution of any contract relating to such Work. The City/Parish shall provide a copy of any modifications to the Consent Decree to each contractor or consultant within (10) days after entry of such modification. The City/Parish shall condition all contracts entered into to perform Work upon conformity with the terms of this Consent Decree.

Any action taken by any contractor or consultant retained by the City/Parish to implement the City/Parish's obligations under this Consent Decree shall be considered an action of the City/Parish for purposes of determining compliance with this Consent Decree. In any action against the City/Parish of enforce this Consent Decree, no act or failure to act by any officer, director, employee, agent, servant, contractor, subcontractor, successor, or assign of the City/Parish shall excuse any failure to comply with the requirements of this Consent Decree.

Deleted: p

V. OBJECTIVES

11. It is the express purpose of the Parties entering into this Consent Decree:

A To require the City/Parish to achieve and maintain compliance with its NPDES/LPDES permits and the CWA;

B To require the City/Parish to perform the Work required by this Consent Decree in compliance with the applicable schedules; and

C To further the goals and objectives of the CWA, particularly Sections 101, 301 and 307, 33 U.S.C. §§ 1251, 1311, and 1317.

VI. DEFINITIONS

12. Unless otherwise defined herein, terms used in this Consent Decree shall have the meanings given to those terms in the Clean Water Act, 33 U.S.C. §§ 1251 et seq., and the regulations promulgated thereunder.

13. Whenever terms listed in this Paragraph are used in this Consent Decree, the following definitions shall apply:

- “BOD” means biochemical oxygen demand.
- “Calendar quarter” means a three month period ending on March 31st, June 30th, September 30th or December 31st.
- “The Central Plant” means the Central Wastewater Treatment plant located at 2553 River Road, in East Baton Rouge Parish, Louisiana.
- “The City/Parish” means the City of Baton Rouge, Louisiana and the Parish of East Baton Rouge, Louisiana.
- “City” means the City of Baton Rouge, Louisiana.
- “Collection system” means the sanitary sewer collection and transmission system (including all pipes, force mains, gravity sewer lines, lift stations, pump stations, manholes, and appurtenances thereto) owned or operated by the City/Parish that serves the North, Central, and South plants. For purposes of this Consent Decree, “Collection System” does not include the sewage collection and transmission

systems owned or operated by Baker, Louisiana; Zachary, Louisiana; Louisiana State University and Agricultural and Mechanical College; Southern University and Agricultural and Mechanical College; agencies of the State of Louisiana; or any other privately maintained sewage collection and transmission systems.

- “Consent Decree” means this Decree, all attachments and exhibits to this Decree, and all items approved by EPA and LDEQ pursuant to Section XVII (Review of Submittals) and any modifications to the Consent Decree approved by the court pursuant to Section XXXIV. In the event of any conflict between this Decree and any attachment, exhibit, or approved item, this Decree shall control.
- “Cross Connection” shall mean any physical connection which allows stormwater or other waters (except sanitary sewage and industrial wastewaters) to flow into the Collection System.
- “CWA” means the Clean Water Act, 33 U.S.C. §§ 1251 et seq.
- “Date of Lodging” means the date this Consent Decree is received by the Clerk of the United States District Court for the Middle District of Louisiana prior to signature by the District Judge assigned to this civil action.
- “Date of Entry” means the date this Consent Decree is filed by the Clerk of the United States District Court for the Middle District of Louisiana after being signed by the District Judge assigned to this civil action.
- “Day” or “days” as used herein shall mean a calendar day or calendar days where the period of time allowed is eleven (11) days or more. “Day” or “Days” shall mean a day other than a Saturday, Sunday, or a State or Federal holiday where the period of time allowed is less than eleven (11) days. When the deadline for submission of a report or other deliverable falls on a Saturday, Sunday or a State or Federal holiday, submission will not be required until the next calendar day that is not a Saturday, Sunday, or State or Federal holiday.
- “Effective Date of this Consent Decree” means the Date of Entry.
- “Eighty-Five Percent Rule” means the monthly average percent removal requirements for TSS and BOD specified in Section A (Effluent Characteristics) of NPDES/LPDES Permits Nos. LA0036412, LA0036421, and LA 0036439. . . . Deleted: NPDES
- “EPA” means the United State Environmental Protection Agency.
- “Fully Operational” means all items identified under a particular requirement have been fully completed and are consistently functioning within the design plan and specifications.

- "Infiltration and Inflow" or "I & I" means the infiltration and the inflow into the North, Central, and South Plant Collection Systems.

Deleted: of groundwater
Deleted: of stormwater

- "Infiltration" is the water entering a sewer system and service connections from the ground, through such means as, but not limited to, defective pipes, pipe joints, connections, or manhole walls.

Formatted: Font: (Default) Times New Roman
Formatted: Bullets and Numbering

- "Inflow" is the water discharged to a sewer system, including service connections, from such sources as, but not limited to, roof leaders; cellar, yard, and area drains; crushed laterals; foundation drains; cooling water discharge; drains from springs and swampy areas; manhole covers; cross-connections from storm sewers; catch basin laterals; stormwater; surface runoff; street wash water; or drainage.

Formatted: Bullets and Numbering

- "LDEQ" means the Louisiana Department of Environmental Quality.
- "Non-Compliant Discharge" means any discharge of wastewater through an outfall from which the City and/or the Parish is permitted to discharge pursuant to NPDES/LPDES Permit Nos. LA0036439, LA0036412, and LA0036421 which is not in compliance with requirements and conditions specified in those permits, except as specifically provided in Section XVI (Interim Effluent Limits).

Deleted: NPDES

- "The North Plant" means the North Wastewater Treatment Plant located at 55 Mills Avenue in East Baton Rouge Parish, Louisiana.

- "NPDES/LPDES Permit No. LA 0036412" means National Pollutant Discharge Elimination System ("NPDES") / Louisiana Pollutant Discharge Elimination System ("LPDES") permit number LA0036412 issued pursuant to CWA Section 402, 33 U.S.C. § 1342, for the South Plant and any future, extended, modified, or reissued NPDES/LPDES permit for the same facility.

- "NPDES/LPDES Permit No. LA 0036421" means National Pollutant Discharge Elimination System ("NPDES") / Louisiana Pollutant Discharge Elimination System ("LPDES") permit number LA0036421 issued pursuant to CWA Section 402, 33 U.S.C. § 1342, for the Central Plant and any future, extended, modified, or reissued NPDES/LPDES permit for the same facility.

- "NPDES/LPDES Permit No. LA 0036439" means National Pollutant Discharge Elimination System ("NPDES") / Louisiana Pollutant Discharge Elimination System ("LPDES") permit number LA0036439 issued pursuant to CWA Section 402, 33 U.S.C. § 1342, for the North Plant and any future, extended, modified, or reissued NPDES/LPDES permit for the same facility.

- "Paragraph" means a portion of this Consent Decree identified by an Arabic numeral.

- "Parish" means the Parish of East Baton Rouge, Louisiana.
- "Parties" means the United States, the State of Louisiana, and the City/Parish.
- "Plaintiffs" means the United States of America and the State of Louisiana.
- "RMAP" means a remedial measures action plan.
- "Section" means a portion of this Consent Decree identified by uppercase Roman numerals.
- "The South plant" means the South Wastewater Treatment plant located at 2850 Gardere Lane in East Baton Rouge Parish, Louisiana.
- "SSO" means sanitary sewer overflow. The term does not include discharges that do not violate the CWA or regulations enacted pursuant to the CWA.
- "Sanitary Sewer" has the same meaning as Collection System.
- "SEP" means Supplemental Environmental Project.
- "State" means the State of Louisiana.
- "Start of Construction" means issuance by the City/Parish of a notice to proceed with construction to the contractor performing the relevant construction project.
- "Subparagraph" means a portion of a Paragraph.
- "Surface Waters" mean waters of the United States as defined by 40 C.F.R. § 122.2.
- "TSS" means total suspended solids.
- "Unauthorized Discharge" means any discharge of wastewater from the North, South, or Central plants or from the Collection Systems for those plants from any point other than the outfall specified in the applicable NPDES/LPDES permit, regardless of whether such discharge reaches navigable waters. The term does not include either (1) discharges that do not violate the CWA or regulations enacted pursuant to the CWA or (2) discharges in compliance with the provisions of Section XVI (Interim Effluent Limits).
- "Work" means all activities that the City/Parish is required to perform under this Consent Decree except those required by Section XIX (Civil Penalties) and Section XXXII (Record Keeping).

Deleted: NPDES

VII. COMPLIANCE WITH CLEAN WATER ACT

14. The City/Parish shall comply at all times with the CWA, the regulations promulgated thereunder, and all terms of NPDES/LPDES Permits Nos. LA0036439, LA0036412, and LA0036421 (except as provided in Section XVI (Interim Effluent Limits)).

VIII. REMEDIAL MEASURES-ELIMINATION OF CROSS CONNECTIONS

15. By its signature on this Consent Decree, the City/Parish certifies that it has permanently closed or eliminated all known Cross Connections in the Collection System.

16. If the City/Parish identifies any Cross Connection in the Collection System subsequent to the Date of Entry of this Consent Decree, it shall permanently seal or eliminate such Cross Connection within thirty (30) days of identification or, if the City/Parish elects to have the work performed by a contractor, within sixty (60) days of identification.

17. The City/Parish shall maintain in effect the following ordinances banning private Cross Connections:

- City of Baton Rouge & Parish of East Baton Rouge, LA., Ordinance 2:308 (Adopted October 13, 1999);
- City of Baton Rouge & Parish of East Baton Rouge, LA., Ordinance 2:309 (Adopted October 13, 1999);
- City of Baton Rouge & Parish of East Baton Rouge, LA., Ordinance 2:319 (Adopted October 13, 1999); and
- City of Baton Rouge & Parish of East Baton Rouge, LA., Ordinance 2:320 (Adopted October 13, 1999);

While the City/Parish is not obligated by this Consent Decree to enter private property to sever Cross Connections, the City/Parish is obligated to effectively enforce the ordinances listed above.

18. Any use of any Cross Connection in the Collection System shall be considered a violation of the CWA and of this Consent Decree.

IX. REMEDIAL MEASURES-PREVENTIVE MEAINTENANCE PROGRAM PLANS

19. No later than March 30, 2001, the City/Parish will submit for review and approval to EPA and LDEQ a Collection System Preventive Maintenance Program Plan. The Collection System Preventive Maintenance Program Plan shall be designed to ensure proper operation and maintenance of the North, Central, and South Plant Collection Systems on a day-to-day basis in compliance with the CWA and NPDES/LPDES Permits Nos. LA0036439, LA0036412, and LA0036421. At a minimum, the Preventive Maintenance Program Plan shall provide for

- (A) Physical inspection and testing procedures for the collection system;
- (B) Preventive and routine maintenance schedules and procedures;
- (C) Corrective maintenance;
- (D) Current staffing, organization, and resource commitments;
- (E) A tracking system for all maintenance activities;
- (F) A list of subjects to be discussed in the Annual Report to be submitted pursuant to Paragraph 52;

(G) An implementation schedule-the implementation schedule shall provide no more than two years for full implementation of the Collection System Preventive Maintenance Program Plan; and

(H) A thorough inspection of the Collection System for the purpose of identifying Cross Connections.

20. If the City/Parish believes that new information or data supports modification of the Collection System Preventive Maintenance Program Plan, the City/Parish may submit to EPA and LDEQ for review and approval a request for modification of the Collection System Preventive Maintenance Program Plan. The request for modification shall describe the modification being requested, the new information or data supporting modification and how such modification would improve the Collection System Preventive Maintenance Program Plan. In its review of any such submittal, EPA and LDEQ will apply industry standards (such as American Waterworks Association (AWWA)/Water Environment Federation (WEF) standard manuals). Until such time as a requested modification is approved, the previously approved Collection System Preventive Maintenance Program Plan shall remain in effect.

Deleted: ¶

21. If, after receipt of an Annual Report pursuant to Paragraph 52, EPA or LDEQ determine that there are one or more violations of this Consent Decree or the Clean Water Act, and that there is a nexus between such violations and the Collection System Preventive Maintenance Program Plan, EPA or LDEQ may require the City/Parish to submit a revised Collection System Preventive Maintenance Program Plan for review and approval under Section XVII (Review of Submittals). Upon receipt of such a notice, the City/Parish shall revise the Collection System Preventive Maintenance

Program Plan to include measures to prevent the identified violations. EPA and LDEQ may make specific recommendations regarding the revisions to the Collection System Preventive Maintenance Program Plan. The City/Parish shall submit the revised Collection System Preventive Maintenance Program Plan within sixty (60) days of receipt of written notice of EPA or LDEQ's requirement that it revise the Collection System Preventive Maintenance Program Plan. Until such time as a revised Collection System Preventive Maintenance Program Plan is approved, the previously approved Collection system Preventive Maintenance Program Plan shall remain in effect.

Deleted: p

22. No later than March 30, 2002, the City/Parish will prepare and implement a Treatment Plant Preventive Maintenance Program Plan. The Treatment Plant Preventive Maintenance Program Plan shall be designed to ensure proper operation and maintenance of the North, Central, and South Plants on a day-to-day basis in compliance with the CWA, NPDES/LPDES Permits Nos. LA0036439, LA0036412, and LA0036421 and, to the extent applicable, Section XVI (Interim Effluent Limits)). The City/Parish shall send notice that it has completed the Treatment Plant Preventive Maintenance Program Plan to the following:

Chief
NPDES Compliance Monitoring Section (6EN-WC)
Water Enforcement Branch
Compliance Assurance and Enforcement Division
United States Environmental Protection Agency—Region 6
1445 Ross Avenue
Dallas, Texas 75202
Re: Baton Rouge Consent Decree

Administrator,
Office of Environmental Compliance
Louisiana Department of Environmental Quality
P.O. Box 4312
Baton Rouge, LA 70821-4312

Deleted: Bruce Hammett

Deleted: 822159

Deleted: 84

Deleted: 2215

Street Address:
602 N. Fifth Street
Galvez Building
Baton Rouge, LA 70802

Deleted: 7290 Bluebonnet Rd #1
LDEQ building

Deleted: 10-1611

The City/Parish may update the Treatment Plant Preventive Maintenance Program Plan as needed, and shall maintain complete copies of the current and all prior versions of the Treatment Plant Preventive Maintenance Program Plan on site at the North, Central, and South Plants.

23. If, after receipt of an Annual Report pursuant to Paragraph 52, EPA or LDEQ determine that there are one or more violations of this Consent Decree or the Clean Water Act, and that there is a nexus between such violations and the Treatment Plant Preventive Maintenance Program Plan, EPA or LDEQ may require the City/Parish to revise the Treatment Plant Preventive Maintenance Program Plan. Upon receipt of such a notice, the City/Parish shall revise the Treatment Plant Preventive Maintenance Program Plan to include measures to prevent the identified violations within sixty (60) days. Until such time as the Treatment Plant Preventive Maintenance Program Plan is revised, the previous Treatment Plant Preventive Maintenance Program Plan shall remain in effect.

X. REMEDIAL MEASURES—SANITARY SEWER OVERFLOW RESPONSE PLAN

24. The City/Parish shall implement the Sanitary Sewer Overflow Response Plan (“SSO Response Plan”) attached to this Consent Decree as Exhibit A. If the City/Parish believes that new information or data supports modification of the SSO Response Plan, the City/Parish may submit to EPA and LDEQ for review and approval a

request for modification of the SSO Response Plan. The request for modification shall describe the modification being requested, the new information or data supporting modification, and how such modification would improve the SSO Response Plan. Until such time as a requested modification is approved, the previously approved SSO Response Plan shall remain in effect.

25. If, after receipt of an Annual Report pursuant to Paragraph 52, EPA or LDEQ determine that there are one or more violations of the Consent Decree or the Clean Water Act, and that there is a nexus between such violations and the SSO Response Plan, EPA or LDEQ may require the City/Parish to submit a revised SSO Response Plan for review and approval under Section XVII (Review of Submittals). Upon receipt of such a notice, the City/Parish shall revise the SSO Response Plan to include measures to prevent the identified violations. EPA and LDEQ may make specific recommendations regarding the revisions to the SSO Response Plan. The City/Parish shall submit the revised SSO Response Plan within sixty (60) days of receipt of written notice of EPA or LDEQ's requirement that it revise the SSO Response Plan. Until such time as a revised SSO Response Plan is approved, the previous SSO Response Plan shall remain in effect.

XI. REMEDIAL MEASURES—REPORTING OF UNAUTHORIZED DISCHARGES

26. The City/Parish shall report all Unauthorized Discharges of which it becomes aware to EPA and LDEQ. All such Unauthorized Discharges shall be reported to EPA and LDEQ in the Quarterly Report to be submitted pursuant to Paragraph 51.

27. In addition to the reporting requirements in Paragraph 26, the City Parish shall orally report all Unauthorized Discharges which have a measurable impact on

human health or the environment (e.g. fish kills) to EPA and LDEQ by telephone within twenty-four (24) hours of the time the Unauthorized Discharge occurs. Within five days after the Unauthorized Discharge, the City/Parish shall submit a written report to EPA and LDEQ addressing the items set forth in the Quarterly Report—Unauthorized Discharge Report Summary Section of Attachment I (Quarterly and Annual Report Format). For purposes of this Paragraph, an Unauthorized Discharge which has a measurable impact on human health shall include, but not be limited to, any unauthorized discharge of more than one hundred thousand (100,000) gallons within a twenty-four (24) hours period.

XII. REMEDIAL MEASURES—COLLECTION SYSTEM REMEDIAL PROGRAM

28. The City/Parish is undertaking a comprehensive collection system remedial action program. The program is intended to minimize and prevent Unauthorized Discharges from the Collection Systems for the North, Central, and south Plants. The program is in progress and will be completed, subject to the provisions of this Consent Decree. The original plan developed by the City/Parish to address Unauthorized Discharges has been referred to as Alternative 1 and included the following elements:

Alternative 1: This alternative is the original base SSO Plan which calls for some 23 storage tanks and a deep tunnel storage system near Airline Highway. Six pump stations would be eliminated under this plan, but another 112 pump stations would be constructed or modified. The primary features of Alternative 1 are depicted on the map attached as Exhibit B.

The City Parish no longer plans to implement Alternative 1 and is currently evaluating the following options for its collection system remedial action program:

Alternative 3: This alternative generally involves constructing four open storage basins, utilizing five Maryland Tank Farm tanks, and approximately eighteen (18) additional storage tanks. This plan would eliminate the tunnel system proposed in Alternative 1. Under this plan, three (3) pump stations would be eliminated but 11 pump stations would be constructed or modified. The primary features of Alternative 3 are depicted on the map attached as Exhibit C.

Alternative 4: This alternative generally includes most of the features of Alternative 3 except that six (6) open storage basins and eighteen (18) storage tanks would be constructed. This alternative would not utilize the Maryland Tank Farm storage tanks. Under this plan, three (3) pump stations would be eliminated but 110 pump stations would be constructed or modified. The primary features of Alternative 4 are depicted on the map attached as Exhibit D.

Alternative 7: This alternative generally includes most of the elements of Alternative 1 and some elements of Alternatives 3 and 4. The features of this plan include utilization of one (1) large storage basin near Airline Highway and South Choctaw Drive, construction of deep underground gravity sewers, construction of three (3) ballasted flocculation waste water treatment facilities, and construction of storage tanks in the Baker and Zachary areas. Under this plan, 112 pump stations would be eliminated and 57 pump stations would be constructed or modified. The primary features of Alternative 7 are depicted on the map attached as Exhibit E.

29. The City/Parish shall implement the First Remedial Measures Action Plan (“the First RMAP”) attached to this Consent Decree as Exhibit F. The First RMAP identifies the common elements of Alternatives 3, 4, and 7 listed in Paragraph 28 and sets forth a schedule for beginning and completing construction for each common element identified. The First RMAP also provides an estimate of the costs of the common elements and a detailed description of how the City/Parish will fund construction and operation and maintenance of the elements to be constructed pursuant to the First RMAP.

Deleted:

30. The City/Parish shall meet the following milestones when implementing the First RMAP:

A. Start construction for the remedial measures identified in the First RMAP by January 15, 2001; and

B. Complete construction of the remedial measures identified in the First RMAP by May 4, 2007.

Formatted: Line spacing: single

Deleted: .

31. No later than December 1, 2002, the City/Parish shall submit to EPA and LDEQ for review and approval a Second Remedial Measures Action Plan ("The Second RMAP"). In the Second RMAP, the City/Parish shall select a remedial measure to be implemented and provide a detailed analysis of how the selected measure will accomplish the objectives of this Consent Decree. The City/Parish proposes a remedial measure other than Alternatives 3, 4, and 7 which will take more than 15 years to implement, EPA and/or LDEQ may disapprove the proposed remedial measure and require the City/Parish to select among Alternatives 3, 4, and 7. EPA's and/or LDEQ's decision to disapprove a proposed remedial measure other than Alternative 3, 4, or 7 on the basis that it will take more than 15 years to implement shall not be subject to dispute resolution pursuant to Section XXIV (Dispute Resolution). In the Second RMAP, the City/Parish shall provide a detailed description of the selected remedial measure and shall specify a schedule for beginning and completing construction of each element of the selected remedial measure not addressed in the First RMAP. The Second RMAP shall also set forth a process for evaluating and providing the personnel and training that will be required to successfully implement the selected remedial measure. The Second RMAP shall also provide an estimate of the cost of the selected remedial measure and a detailed description of how the City/Parish will fund the remedial measure to be implemented.

Deleted: shall

32. EPA and LDEQ evaluated the Second RMAP as provided in Section XVII (Review of Submittals) for consistency with this Consent Decree, including Section V

(Objectives), and industry standards current at the time the Second RMAP is submitted.

Following such review, the Second RMAP was approved by EPA and LDEQ.

33. At any time after the Second RMAP is approved by EPA and/or LDEQ pursuant to Section XVII (Review of Submittals), the City/Parish may submit for review and approval pursuant to Section XVII (Review of Submittals) a proposal to modify the remedial measure selected in the Second RMAP. Any proposal to modify the Second RMAP or Revised Second RMAP shall be evaluated by EPA and LDEQ for consistency with this Consent Decree, including Section V (Objectives), and industry standards current at the time the proposal is submitted.

A. EPA and/or LDEQ may disapprove any proposal to modify the Second RMAP which would extend the completion date for the remedial measure past the deadline in the approved Second RMAP. EPA's and/or LDEQ's decision to disapprove a proposed modification on the basis that it will be completed after the completion date for the remedial measure in the approved Second RMAP shall not be subject to dispute resolution pursuant to Section XXIV (Dispute Resolution).

B. Any proposed modification of the Second RMAP or Revised Second RMAP which would extend the schedule for completion of the work or materially alter the selected remedial measure shall require the approval of the Court.

34. In the Second RMAP, the City/Parish shall propose the following milestones:

A. Completion of design for remedial measures identified in the Second RMAP;

B. Thirty-three percent (33%) completion of construction of the complete remedial measure described in the First and Second RMAPs (the proposal shall specify the tasks which must be completed to demonstrate that this milestone has been achieved);

C. Sixty-six percent (66%) completion of construction of the complete remedial measure described in the First and Second RMAPs (the proposal shall specify the tasks which must be completed to demonstrate that this milestone has been achieved); and

D. Completion of all construction and fully operational status achieved. The date for this milestone shall be:

- i. January 1, 2013 if the City/Parish selects as a remedial measure Options 3 or 4.
- ii. January 1, 2015 if the City/Parish selects as a remedial measure Options 7.
- iii. The earliest date on which the milestone can reasonably be achieved considering how quickly it is physically and financially possible to complete construction, if the City/Parish selects a remedial measure other than Options 3, 4, or 7.

34A. The EPA and LDEQ have approved a modification to the Second Remedial Action Plan, hereinafter referred to as the Revised Second RMAP. The

Deleted: 1

Revised Second RMAP is attached as Exhibit K to this Consent Decree. Revised Second RMAP includes the following milestones:

A. Completion of design for remedial measures identified in the Revised Second RMAP;

B. Thirty-three percent (33%) completion of construction of the complete remedial measure described in the Revised Second RMAPs (the proposal shall specify the tasks which must be completed to demonstrate that this milestone has been achieved);

C. Sixty-six percent (66%) completion of construction of the complete remedial measure described in the Revised Second RMAPs (the proposal shall specify the tasks which must be completed to demonstrate that this milestone has been achieved); and

D. Completion of all construction and fully operational status achieved. The date for this milestone shall be January 1, 2015.

Formatted: Indent: Left: 0.5", Hanging: 0.5"

[Note: Paragraph 35 deleted as unnecessary as I/I is central feature of the Revised Second RMAP and will be required per paragraph 34A. and attachment K.]

Deleted: 35. During the period from Entry of the Consent Decree until the City/Parish meets the milestone specified in Paragraph 34(D), the City/Parish shall spend at least \$3 million per year for sewer repairs, sewer rehabilitation, and other capital needs related to reduction of Infiltration and Inflow ("I & I") into the North, Central, and South Plant Collection Systems. These expenditures will be documented in the Annual Report submitted pursuant to Paragraph 52.

XIII. REMEDIAL MEASURE—TREATMENT FACILITY ASSESSMENT

36. No later than March 30, 2002, the City/Parish shall submit to EPA and LDEQ for review and approval a Treatment Facility Assessment Report which assesses the treatment capabilities of the North, Central, and South Plants. The Treatment Facility Assessment Report shall analyze (1) the hydraulic and organic design capacity and

current and projected loading of each plant, including peak and low flows and (2) the ability of the plant to meet effluent limitations required by the applicable ~~NPDES/LPDES~~ Permit. The Treatment Facility Assessment Report shall evaluate whether improvement or expansion of the North, Central, and/or South Plant are required to allow the plants to handle projected loading while fully complying with the applicable ~~NPDES/LPDES~~ permit and whether any change(s) in the current operation and/or maintenance of the North, Central, and/or South Plants will be required to attain or maintain compliance with the applicable ~~NPDES/LPDES~~ permit. If the report concludes that improvements, expansion or changes in the operation and/or maintenance of the North, Central, and/or South Plants are required, the report shall include a schedule for implementing the required improvements, expansion, and/or changes.

Deleted: NPDES

Deleted: NPDES

Deleted: NPDES

XIV. REMEDIAL MEASURE—ENVIRONMENTAL RESULTS MONITORING PLAN

37. The City/Parish shall implement the Environmental Results Monitoring Plan attached as Exhibit G. The Environmental Results Monitoring Plan is designed to measure environmental benefits resulting from the Work performed under this Consent Decree through measurement of water quality improvements.

XV. OUTREACH AND PUBLIC AWARENESS

38. The Parties agree that an effective public education program will assist in fulfilling the purpose of this Consent Decree. This is particularly important in advising the public of steps they can take to minimize impact on the collection system, improve environmental compliance, and educate local groups. Accordingly, the City/Parish shall implement the Outreach and Public Awareness Program (Exhibit H).

XVI. INTERIM EFFLUENT LIMITS

Deleted: T

39. Except as provided in Paragraph 39A, the interim relief provisions of this Paragraph shall be in effect beginning on the Date of Entry of the Consent Decree and ending on the date for completion of construction and fully operational status achieved pursuant to Paragraph 34A(D). During this period, the City/Parish shall not be liable for stipulated penalties for failure to comply with the Eighty-Five Percent Rule as specified in NPDES/LPDES Permits Nos. LA0036412, LA0036421, and LA0036439 provided that the thirty (30) days average amount of BOD and TSS in the waste water discharged from the North, Central, and South plants is at least seventy-five percent (75%) less than the amount of BOD and TSS in the sewage entering the plant.

39A. The interim relief provisions of this Paragraph shall be in effect in addition to the interim limits of Paragraph 39 beginning upon the effective date of the Modified Consent Decree and ending on the date thirty (30) days after the completion of shakedown of the conversion of the South Plant to an activated sludge system, pursuant to the schedules contained in the Revised Second RMAP, Exhibit K. This relief is necessary during the time period for the implementation of the approved improvements to the South Plant pursuant to the schedule provided in the Revised Second RMAP. During this period, the City/Parish shall not be liable for stipulated penalties for failure to comply with the effluent limitations in the South Plant NPDES/LPDES Permit No. LA0036412 with respect to the parameters for which interim limits are provided in this Paragraph provided that the South Plant effluent meets the interim limitations provided below:

Monthly BOD₅ = 45 mg/l Weekly BOD₅ = 60 mg/l

Formatted: Subscript
Formatted: Subscript

42. In the case of decisions by EPA and LDEQ on an item submitted for review and approval which are issued on the same day, the City/Parish shall commence implementation of the Work required by the item in accordance with the approved schedule within thirty (30) days after receipt of notice of EPA and LDEQ's decisions.

43. In the case of decisions on an item submitted for review and approval which are issued by EPA and LDEQ on different days, the City/Parish shall commence implementation of the Work required by the item in accordance with the approved schedule within thirty (30) days after the soonest of the following dates:

A. The date of the decision issued by the agency to decide first in time if the other agency has previously notified the City/Parish pursuant to Paragraph 41 that it waives its right to decide;

B. The date that the second agency notifies the City/Parish pursuant to Paragraph 41 that it waives its right to decide, if that notice is issued after the decision issued by the agency to decide first in time;

C. The date of the decision issued by the agency that decides second in time; or

D. The date that the right of the second agency to issue decision is waived under Paragraph 41.

44. In the case of an item approved subject to specified conditions or modified and approved in a decision issued by EPA or LDEQ, the City/Parish may invoke the dispute resolution procedures set forth in Section XXIV (Dispute Resolution) with respect to EPA's or LDEQ's decision. Regardless of whether the City/Parish invokes such dispute resolution procedures, if the City/Parish fails to timely commence

implementation of the Work required by the item approved subject to specified conditions or modified and approved, it shall be liable for any stipulated penalties due under Section XXI (Stipulated Penalties).

45. A. In the case of an item which has been disapproved, in whole or in part, by EPA or LDEQ, the City/Parish shall, within thirty (30) days of receipt of the notice of disapproval, correct the deficiencies and resubmit the item for approval. The City/Parish may also invoke the dispute resolution procedures set forth in Section XXIV (Dispute Resolution) with respect to a notice of disapproval. Regardless of whether the City/Parish invokes such dispute resolution procedures, if it fails to timely correct the deficiencies specified in the notice of disapproval and resubmit the item, (i) the City/Parish shall be liable for any stipulated penalties due under Section XXI (Stipulated Penalties) and (ii) EPA and/or LDEQ may modify and approve the item. An item that is resubmitted with the same deficiencies which were identified in the notice of disapproval or with substantially similar deficiencies shall be deemed to have never been submitted for purposes of calculating stipulated penalties.

B. Notwithstanding the receipt of a notice of disapproval pursuant to Paragraph 40, the City/Parish shall proceed, if so directed by EPA or LDEQ in the notice, to take any action required by any non-deficient portion of the item. The City/Parish shall commence implementation of such actions by the dates specified in Paragraphs 42 and 43.

C. In the event that a resubmitted item, or portion thereof, is disapproved by EPA or LDEQ, EPA and/or LDEQ may again require the

City/Parish to correct the deficiencies in accordance with the procedure set forth in this Paragraph. EPA and/or LDEQ may also approve the item subject to conditions specified in the approval notice or modify and approve the item as set forth in Paragraph 40 above. In the event that EPA and/or LDEQ approve the item subject to specified conditions or modify and approve the item, the City/Parish shall commence implementation of the Work required by the item in accordance with the approved schedule by the dates specified in Paragraphs 42 and 43. The City/Parish may also invoke the dispute resolution procedures set forth in Section XXIV (Dispute Resolution) with respect to a decision by EPA or LDEQ pursuant to this Subparagraph. Regardless of whether the City/Parish invokes such dispute resolution procedure, if the City/Parish fails to timely re-submit the item or to implement the Work required by the item as approved, the City/Parish shall be liable for any stipulated penalties due under Section XXI (Stipulated Penalties).

46. All items required to be submitted to EPA and LDEQ for review and approval under this Consent Decree shall, upon approval, approval subject to specified conditions, or modification and approval by EPA or LDEQ, be enforceable under this Consent Decree. In the event EPA or LDEQ approves; approves subject to specified conditions, or modifies and approves a portion of an item required to be submitted to EPA and LDEQ under this Consent Decree, the approved or modified portion shall be enforceable under this Consent Decree.

47. If the City/Parish timely submits an item for review and approval and either EPA or LDEQ issues a decision regarding the submittal more than sixty (60) days

after the date the item was submitted, then the City/Parish shall be entitled to an extension of any interim or final deadlines which the City/Parish will be unable to meet as a result of the length of the review process. Any such request must be in writing and must identify the deadlines for which an extension is requested, the length of the extension requested, and set forth the basis for (1) the City/Parish's claim that it is unable to meet the deadline(s) due to the length of the review process and (2) the length of the extension requested. An extension will be considered granted after both EPA and LDEQ consent to the extension in writing.

48. If the City/Parish determines that a difference in the decisions by EPA and LDEQ regarding an item submitted for review under this Consent Decree will impose inconsistent obligations upon it, the City/Parish may invoke the procedures set forth in Section XXIV (Dispute Resolution). If, after the completion of the dispute resolution procedures set forth in Paragraph 93(B) or 94(A), the City/Parish still maintains that the decisions by EPA and LDEQ impose inconsistent obligations upon it, the City/Parish may move the Court to stay performance of the obligations which the City/Parish maintains are inconsistent until the matter is fully resolved pursuant to the procedures set forth in Section XXIV (Dispute Resolution).

49. all documents to be submitted for review and approval pursuant to this Consent Decree, including but not limited to, reports, approvals, disapprovals, and related correspondence, shall be sent to the following addresses or any other address that the City/Parish, EPA, and LDEQ hereafter agree upon in writing:

A. Three (3) copies of each document to be submitted to EPA should be sent to:

Chief
NPDES Compliance Monitoring Section (6EN-WC)

Water Enforcement Branch
Compliance Assurance and Enforcement Division
United States Environmental Protection Agency—Region 6
1445 Ross Avenue
Dallas, Texas 75202
re: Baton Rouge Consent Decree

B. Three (3) copies of each document to be submitted to LDEQ should be sent to:

Administrator
Office of Environmental Compliance
Louisiana Department of Environmental Quality
P.O. Box 4312
Baton Rouge, LA 70821-4312

Deleted: Bruce Hammett

Deleted: 82215

Deleted: 84

Deleted: 2215

Street Address:
621 N. Fifth Street
Galvez Building
Baton Rouge, LA 70802

Deleted: 7290 Bluebonnet Road

Deleted: §
. LDEQ

Deleted: 10-1611§

C. One copy of each document to be submitted to the City/Parish should be sent to:

Director
Department of Public Works
City of Baton Rouge
Parish of East Baton Rouge
Post Office Box 1471
Baton Rouge, Louisiana 70821

Deleted: Fred E. Raiford III

Street Address:
300 North Boulevard, Rm. 208
Old Municipal Building
Baton Rouge, Louisiana 70802

50. Except as specifically provided in Section XVIII (Reporting), all documents submitted by the City/Parish to EPA and LDEQ for review and approval under this Consent Decree shall be signed by an authorized representative of the City/Parish and shall include the following certification statement:

I certify under penalty of law that this document and all attachments were prepared under my direction and supervision in accordance with a system designed to assure that qualified personnel properly gather and evaluate the information submitted. Based upon my inquiry of either the person or persons who manage the system and/or the person or persons directly responsible for gathering the information, the information submitted is, to the best of my knowledge and belief, true, accurate, and complete. I further certify, to the best of my knowledge and belief, that this document is consistent with the applicable requirements of the Consent Decree entered among the United States, the State of Louisiana, the City of Baton Rouge, and the Parish of East Baton Rouge in the matter of United States v. Baton Rouge, No. 88-191A (M.D. La.). I am aware that there are significant penalties for submitting false information, including the possibility of fine and imprisonment for knowing violations.

XVIII. REPORTING

51. Beginning with the first Calendar Quarter following entry of this Consent Decree, and each Calendar Quarter thereafter until termination of the decree, the City/Parish shall submit to EPA and LDEQ for review and approval a Quarterly Report. The Quarterly Report shall be due on the thirtieth day following the end of each Calendar Quarter. The Quarterly Report shall address the items set forth in Exhibit 1 to this Consent Decree (Quarterly and Annual Report Format). The items to be addressed in the Quarterly Report may be modified by written agreement of the Parties or by EPA and LDEQ approval of an Annual Report submitted pursuant to Paragraph 52 which contains a request by the City/Parish to modify the items to be addressed in the Quarterly Report.

52. Beginning on January 31, 2002 and every twelve (12) months thereafter until termination of this Consent Decree, the City/Parish shall submit to EPA and LDEQ for review and approval an Annual Report. The Annual Report shall cover the most recent one year period from January 1 to December 31. The Annual Report shall address the items set forth in Exhibit 1 to this Consent Decree (Quarterly and Annual Report Format). The items to be addressed in the Annual Report may be modified by written

agreement of the Parties or by EPA and LDEQ approval of an Annual Report submitted pursuant to this Paragraph which contains a request by City/Parish to modify the items to be addressed in the Annual Report.

53. No later than twenty-one (21) days following completion of any milestone set pursuant to Paragraph 30 or 34, the City/Parish shall submit to EPA and LDEQ a written statement indicating when the milestone was achieved.

54. All reports required to be submitted pursuant to this section shall contain a certification signed by a responsible official of the City/Parish. The certification shall read as follows:

I certify that the information contained in or accompanying this [insert name of submission/document] is true, accurate and complete. As to (the/those) identified portion(s) of this (submission/document) for which I cannot personally verify (its/their) truth and accuracy, I certify as the official having supervisory responsibility for the person(s) who, acting under my direct instructions, made the verification, that this is true, accurate and complete.

XIX. CIVIL PENALTY

55. The City/Parish shall pay a civil penalty in the amount of Seven Hundred Twenty Nine Thousand Five Hundred dollars (\$729,500). Payment shall be due within thirty days after the Date of Entry of the Consent Decree. Payment of the civil penalty shall be made as follows:

A. The City/Parish shall pay \$364,750 to the United States by Electronic Funds Transfer ("EFT") to the U.S. Department of Justice ("DOJ") lockbox bank, referencing DOJ No. 90-5-1-1-2769/1. Payment shall be made in accordance with instructions provided by the United States to the City/Parish

following lodging of this Consent Decree. Any EFT received at the DOJ lockbox bank after 11:00 A.M. Eastern Time will be credited on the next business day.

B. The City/Parish shall pay \$374,750 to Louisiana in the form of a certified check, made payable to the "Louisiana Department of Environmental Quality," and delivered to Darryl Serio, Office of the Secretary, P.O. Box 82263, Baton Rouge, Louisiana, 70884.

56. This civil penalty shall be considered a money judgment in favor of the United States and the State of Louisiana. The remedies provided in the Federal Debt Collection Procedures Act, 28 U.S.C. § 3001 *et seq.*, shall be available to the United States for purposes of collection of this civil penalty. Remedies under any applicable federal or state law shall be available to the State of Louisiana for purposes of collection of this civil penalty.

57. At the time the City/Parish makes payment pursuant to Paragraph 55, it shall send a letter to the persons listed below which states the date payment was made and the amount of the payment. The letter shall include the caption, civil action number and judicial district of this action. The letter should be mailed to the following:

Regional Counsel
Office of Regional Counsel
U.S. Environmental Protection Agency, Region 6
1445 Ross Avenue, Suite 1200
Dallas, Texas 75202-2733

Chief
NPDES Compliance Monitoring Section (6EN-WC)
Water Enforcement Branch
Compliance Assurance and Enforcement Division
United States Environmental Protection Agency—Region 6
1445 Ross Avenue
Dallas, Texas 75202
re. Baton Rouge Consent Decree

Chief
Environmental Enforcement Section
Environment and Natural Resources Division
U.S. Department of Justice
P.O. Box 7611
Washington, DC 20044-7611
re: DOJ No. 90-5-1-1-2769/1

Chief, Civil Division
United States Attorney's Office for the
Middle District of Louisiana
777 Florida St., Room 208
Baton Rouge, Louisiana 70801

Ted Broyles
Legal Affairs Division
Louisiana Department of Environmental Quality
P.O. Box _____
Baton Rouge, LA 70821

Deleted: John B. King
Chief Attorney
Deleted: q
Deleted: 822821
Deleted: 84
Deleted: 2282

58. If the City/Parish fails to tender all or any portion of the civil penalty payment within thirty (30) days of the Effective Date of this Consent Decree, then interest on the civil penalty shall accrue from the date payment was due on any unpaid portion of the penalty at the rate established pursuant to 28 U.S.C. § 1961 in effect on the Date of Entry and shall continue to accrue until full payment is made. Interest shall be compounded annually. The City/Parish shall also be liable for stipulated penalties pursuant to Section XXI (Stipulated Penalties) for any failure to comply with the requirements of Paragraph 55.

59. If the City/Parish fails to pay the civil penalty when due, the United States and/or Louisiana may institute proceedings to collect the penalties and interest. If such a proceeding is instituted, the City/Parish shall be liable to reimburse the United States and/or Louisiana for its expenses and attorney fees connected with the proceeding.

Attorney fees shall be allowable at the maximum rate permitted under 28 U.S.C. § 2412(d)(2)(A)(ii) without finding of special factors.

XX. SUPPLEMENTAL ENVIRONMENTAL PROJECTS

60. The City/Parish shall conduct a Supplemental Environmental Project ("SEP") in accordance with the SEP Plan Requirements attached as Exhibit J. The SEP will consist of connecting sewage lines in certain subdivisions and urbanized areas within the City/Parish to the City/Parish treatment plants. The SEP will be completed in accordance with the schedule specified in the SEP Plan Requirements.

61. The City/Parish shall spend no less than \$1,125,000 on the SEP. No part of this expenditure shall include federal funds, including low interest federal loans, federal contracts or federal grants. Expenditures unrelated to the goals of the SEP as stated above will not count towards the requisite expenditure amount. The City/Parish shall also sponsor a public information program designed to educate the public in the City of Baton Rouge and the Parish of East Baton Rouge of the benefits of the SEP. The public information program must acknowledge that the SEP will be implemented as part of this Consent Decree.

62. The City/Parish shall complete the SEP in accordance with the milestones contained in the SEP Plan Requirements (Exhibit J) and submit a SEP Completion Report no later than two years and six months from the Date of Entry of this Consent Decree. The SEP report shall contain the following information.

- A. A detailed description of the SEP as implemented and of any aspects of the work performed which differed from the SEP Plan Requirements;

B. A description of any operating problems encountered and the solutions thereto;

C. Itemized costs, documented by copies of purchase orders, force accounts and receipts or canceled checks (which shall be made available to the United States, if requested);

D. Certification that the SEP has been fully implemented pursuant to the SEP Plan Requirements and the provisions of this Consent Decree;

E. A description of the environmental and public health benefits resulting from implementation of the SEP.

63. If, following receipt of the City/Parish's SEP Completion Report pursuant to Paragraph 72, EPA or LDEQ determine that the SEP has not been completed in compliance with the requirements of this Consent Decree:

A. The City/Parish shall pay an additional civil penalty in the amounts specified in this subparagraph except as specifically provided Subparagraph B. For each SEP Project described in the SEP Plan Requirements which is not completed in compliance with the requirements of this Consent Decree, the City/Parish shall pay additional civil penalties in the amounts shown in the table below:

Additional Civil Penalties for Failure to Complete SEP Projects in Compliance with the Requirements of this Consent Decree	
SEP Project	Amount of Additional Civil Penalty
Donwood/Oak Manor Project	\$125,000
Pleasant Hills/Green Acres Project	\$250,000
Sharon Hills/Cedar Glenn/Pleasant Hills Project	\$650,000
Stumberg Lane Project	\$100,000

B. If EPA and LDEQ determine that the City/Parish (i) made good faith and timely efforts to complete the project and (ii) has certified, with supporting documentation, that at least ninety percent (90%) of the amount of money which was required to be spent was expended on the SEP, then the City/Parish will not be required to pay any additional civil penalty.

Any payments of additional civil penalties pursuant to this Paragraph shall be made according to the method set forth in Paragraph 55.

64. If, following receipt of the City/Parish's SEP Completion Report pursuant to Paragraph 62, EPA and LDEQ determine that the SEP has been completed in compliance with the requirements of this Consent Decree and that the City/Parish:

A. Expended less than \$1,012,500 on the SEP, then the City/Parish shall pay any portion of that amount not expended or obligated on the SEP to the United States' Treasury as an additional civil penalty.

B. Expenses \$1,012,500 or more on the SEP, then the City/Parish will not be required to pay any additional civil penalty.

Any payments of additional civil penalties pursuant to this Paragraph shall be made according to the method set forth in Paragraph 55.

65. The City/Parish hereby certifies that it is not required to perform or develop the SEP by any federal, state or local law or regulation; nor is the City/Parish required to perform or develop the measures to be taken under the SEP by agreement, grant or as injunctive relief in this or any other case or in compliance with state or local requirements. The City/Parish further certifies that it has not received, and is not presently negotiating to receive, credit for the SEP in any other enforcement action.

XXI STIPULATED PENALTIES

66. Past Stipulated Penalties: In settlement of claims by the United States for stipulated penalties under the 1988 Consent Decree in United States v. Baton Rouge, No. 88-191A (M.D. La.) through the Effective Date of this Consent Decree, the City/Parish shall pay to the United States stipulated penalties in the amount of \$216,000. Payment shall be made within thirty (30) days of the Date of Entry according to the method set forth in Paragraph 55(A).

67. Failure to Submit Timely Reports: The City/Parish shall be liable to Plaintiffs for stipulated penalties in the amounts set forth below for each day past the applicable deadline the City/Parish fails to submit the Collection System Preventive Maintenance Program Plan pursuant to Paragraph 19, the Treatment Facility Assessment Report pursuant to Paragraph 36, a Quarterly Report pursuant to Paragraph 51, and Annual Report pursuant to Paragraph 52, the SEP Completion Report pursuant to Paragraph 62, or to resubmit any disapproved item (except the Second RMAP) pursuant to Paragraph 45. The stipulated penalties for failure to meet the deadline for submission of these reports shall be as follows:

<u>Stipulated Penalties for Failure to Submit Timely Reports</u>	
<u>Period of Noncompliance</u>	<u>Penalty per Day per Violation</u>
1 st to 30 th day	\$500
31 st to 60 th day	\$1000
More than 60 days	\$2500

68. Failure to Submit Timely and Complete Second RMAP: The City/Parish shall be liable to Plaintiffs for stipulated penalties, as set forth below, for each day the City/Parish fails to timely submit a complete Second RMAP pursuant to Paragraph 31 or to resubmit a disapproved Second RMAP pursuant to Paragraph 45. The stipulated

penalties for failure to meet the deadline for submission of the RMAPs shall be as follows:

Stipulated Penalties for Failure to Timely Submit Second RMAP	
Period of Noncompliance	Penalty per Day per Violation
1 st to 30 th day	\$1000
31 st to 60 th day	\$2000
More than 60 days	\$5000

69. Failure to meet RMAP and Construction Milestones: The City/Parish shall be liable to Plaintiffs for stipulated penalties in the amounts set forth below for each day the City/Parish fails to meet the milestone dates set pursuant to Paragraphs 30 and 34. The stipulated penalties for failure to meet the milestones shall be as follows:

Stipulated Penalties for Failure to Meet Milestone	
Period of Noncompliance	Penalty per Day per Violation
1 st to 30 th day	\$2000
31 st to 60 th day	\$5000
More than 60 days	\$10,000

Provided that construction is begun on or before the required date, the City/parish shall place in an account approved by EPA any stipulated penalties due for failure to meet an interim construction milestone set pursuant to Paragraph 30 or 34. Within thirty days of completion of the remedial measure, the City/Parish shall pay such stipulated penalties together with all accrued interest, unless it establishes that the construction of the remedial measure was completed and full operational status achieved on or before the milestone date set pursuant to Paragraph 34(D).

70. The City/Parish shall be liable to Plaintiffs for stipulated penalties as set forth below for each day the City/Parish fails to satisfy any of the following requirements:

A. \$2,000 for each day the City/Parish fails to seal or eliminate newly discovered cross connections by the deadline specified in Paragraph 16;

B. \$15,000 for each day the City/Parish fails to submit the civil penalty required by Paragraph 55 or the stipulated penalty required by Paragraph 66.

71. Pre-Remedial Action Unauthorized Discharges: Prior to the date for completion of all Work specified in the First and Second RMAPs, the City/Parish shall be liable to Plaintiffs for stipulated penalties as follows:

A. For any Unauthorized Discharge which results in the release of less than one million (1,000,000) gallons during its entire duration, the City/Parish shall be liable to Plaintiffs for stipulated penalties of \$5000 per day for each day of each such Unauthorized Discharge except as specifically provided in this Subparagraph. The City/Parish shall not be liable to Plaintiffs for stipulated penalties if the City/Parish is in compliance with the Collection system Preventive Maintenance Program Plan (if approved by EPA and/or LDEQ pursuant to Section XVII (Review of Submittals) at the time of the discharge) and the City/Parish followed the SSO Response Plan in responding to and mitigating the impact of the discharge.

B. For any Unauthorized Discharge which results in the release of one million (1,000,000) gallons or more during its entire duration, the City/Parish shall be liable to Plaintiffs for stipulated penalties of \$5000 per day for each day of each such Unauthorized Discharge.

72. Post-Remedial Action Unauthorized Discharges: After the date for completion of all Work specified in the First and Second RMAPs:

A. For any Unauthorized Discharge which results in the release of less than one million (1,000,000) gallons during its entire duration:

i. The City/Parish shall be liable to Plaintiffs for stipulated penalties of \$5,000 per day for each day of each Unauthorized Discharge if the City/Parish is not in compliance with the Collection system Preventive Maintenance Program Plan or if the City/Parish failed to follow the SSO Response Plan in responding to and mitigating the impact of the discharge.

ii. The City/Parish shall be liable to Plaintiffs for stipulated penalties of \$1,000 per day for each day of each Unauthorized Discharge if the City/Parish is in compliance with the Collection System Preventive Maintenance Program Plan and the City/Parish followed the SSO Response Plan in responding to and mitigating the impact of the discharge.

B. For any Unauthorized Discharge which results in the release of one million (1,000,000) gallons or more during its entire duration, the City/Parish shall be liable to Plaintiffs for stipulated penalties of \$5,000 per day for each day of each such Unauthorized Discharge.

73. Non-Compliant Discharge: The City/Parish shall be liable to Plaintiffs for stipulated penalties for Non-Compliant Discharges. For violations of any Daily Maximum limits, the City/Parish shall be liable to Plaintiffs for stipulated penalties of \$1,000 per parameter per day per facility. For violations of any Weekly Average limits,

the City/Parish shall be liable to Plaintiffs for stipulated penalties of \$1,000 per parameter per week per facility. For violations of any 30-Day Average or Monthly Average limits, the City/Parish shall be liable to Plaintiffs for stipulated penalties of \$2,500 per parameter per month per facility.

74. Supplemental Environmental Projects: The City/Parish shall be liable to Plaintiffs for stipulated penalties of \$2,500 per day for each day that the City/Parish fails to meet the milestone dates for commencement of work for the Supplemental Environmental Projects in accordance with the schedule contained in the Supplemental Environmental Project Plan Requirements (Exhibit J).

75. All stipulated penalties shall begin to accrue on the first day the City/Parish fails to satisfy any obligation or requirement of this Consent Decree and shall continue to accrue through the day the City/Parish satisfies the obligation or requirement of this Consent Decree.

[Note: no paragraph 76 in original]

77. Payment of stipulated penalties as set forth above shall be in addition to any other rights or remedies which may be available to the United States or the State of Louisiana by reason of the City/Parish's failure to comply with the requirements of this Consent Decree and all applicable Federal, state or local laws, regulations, wastewater discharge permit(s) and all other applicable permits.

78. Unless otherwise specifically provided in this Consent Decree, stipulated penalties shall be due and owing no later than thirty (30) days following the City/Parish's receipt from the United States or the State of Louisiana setting forth a demand for payment, except as specifically provided in Paragraph 79. However, neither Plaintiff may

accept payment in an amount less than the full amount of the stipulated penalties owed for the violation identified in the demand for payment without the written consent of the other Plaintiff. One half of the total amount of stipulated penalties due shall be paid to the United States by tendering a certified or cashier's check in an amount due payable to "Treasurer, the United States of America" to the United States Attorney for the Middle District of Louisiana, 777 Florida St., Room 208, Baton Rouge, Louisiana 70801. The other half of the total amount due shall be paid to the State of Louisiana in the form of a certified check, made payable to the "Louisiana Department of Environmental Quality," and delivered to Darryl Serio, Office of the Secretary, P.O. Box 82263, Baton Rouge, Louisiana, 70884. Payments shall be accompanied by a transmittal letter which references United States v. Baton Rouge (M.D. La.) and the civil action number of this case, states the amount being paid, and specifically describes the violations which are the basis for the stipulated penalty being paid. At the time of payment, copies of the transmittal letter and the certified and/or cashier's check shall be sent to:

Chief
Environmental Enforcement Section
Environmental and Natural Resources Division
United States Department of Justice
Post Office Box 7611
Washington, D.C. 20044-7611
Ref: DOJ# 90-5-1-1-2769/1

Director
Compliance Assurance and Enforcement Division
United States Environmental Protection Agency, Region 6
1445 Ross Avenue
Dallas, Texas 75202-2733

Ted Broyles
Legal Affairs Division
Louisiana Department of Environmental Quality
P.O. Box _____

Deleted: John B King
Chief Attorney

Deleted: 82282

Deleted: 8

Deleted: 4

Deleted: 2282

79. If the City/Parish invokes dispute resolution pursuant to Section XXIV (Dispute Resolution), stipulated penalties shall continue to accrue as provided in this Section during the pendency of any dispute resolution proceeding but such stipulated penalties need not be paid until the following:

A. If the dispute is resolved by agreement or by a decision by the Director of the Compliance Assurance and Enforcement Division of EPA Region 6 or the Secretary of LDEQ that is not appealed to this Court, accrued penalties shall be paid within fifteen (15) days of the agreement or decision. The City/Parish shall not be liable for any stipulated penalties if it prevails in the dispute or if the parties to the dispute so agree.

B. If the dispute is appealed to the Court and the EPA or LDEQ prevails in whole or in part, accrued penalties determined by the Court to be owing shall be paid within thirty (30) days of receipt of the Court's decision or order, except as provided in Subparagraph C;

C. If the District Court's decision is appealed by any Party, the City/Parish shall pay all accrued penalties determined by the District Court to be owing into an interest-bearing escrow account within thirty (30) days of receipt of the Court's decision or order. Every thirty (30) days after making the initial payment into the escrow account, the City/Parish shall pay into the escrow account all stipulated penalties which have accrued during the interim since the last payment. Within fifteen (15) days of receipt of the final appellate court decision, the escrow agent shall pay the balance of the account to the Plaintiffs (in

accordance with the payment instruction set forth in Paragraph 78) or to the City/Parish, whichever prevails.

80. In the event that a stipulated penalty is not paid when due, the stipulated penalty shall be payable with interest from the original due date to the date of payment at a rate equal to the statutory judgment rate set forth at 28 U.S.C. § 1961(a) in effect on the date the penalty becomes due plus ten percent (10%).

81. The payment of stipulated penalties shall not alter in any way the City/Parish's obligation to complete performance of the Work required under this Consent Decree.

82. If the City/Parish fails to pay any stipulated penalties when due, the United States and/or the State of Louisiana may institute proceedings to collect the stipulated penalties and interest. If such a proceeding is instituted, the City/Parish shall be liable to reimburse the United States and/or the State of Louisiana for its expenses and attorney fees connected with the proceeding. Attorney fees shall be allowable at the maximum rate permitted under 28 U.S.C. § 2412(d)(2)(A)(ii) without a finding of special factors.

83. For purposes of collection, any stipulated penalties which become due shall be considered a money judgment in favor of the United States and the State of Louisiana. The remedies provided in the Federal Debt Collection Procedures Act (except the provisions of § 3201(e)), 28 U.S.C. § 3001 et seq., shall be available to the United States for purposes of collection of any stipulated penalties.

XXII. FORCE MAJEURE

84. "Force Majeure" for the purposes of this Consent Decree is defined as an event arising from causes beyond the control of the City/Parish or the control of any entity controlled by the City/Parish, including their agents, consultants and contractors, which delays or prevents the performance of any obligation under this Consent Decree despite the City/Parish's best efforts to fulfill the obligation. Unanticipated or increased costs or expenses associated with implementation of this Consent Decree and changed financial circumstances shall not, in any event, be considered force majeure events. Failure to apply for a required permit or approval or to provide in a timely manner all information required to obtain a permit or approval that is necessary to meet the requirements of this Consent Decree, or failure of the City to approve contracts, shall not, in any event, be considered force majeure events. The requirement that the City/Parish exercise "best efforts to fulfill the obligation" includes using best efforts to anticipate any potential force majeure event and best efforts to address the effects of a potential force majeure event (a) as it is occurring and (b) following the potential force majeure event, such that the delay is minimized to the greatest extent practicable. "Force Majeure" does not include financial inability to complete the Work.

85. Within ten days of the date the City/Parish knew or, by the exercise of due diligence, should have known, whichever is first in time, of an event that might delay completion of any requirement of this Consent Decree, regardless of whether the event is a Force Majeure event, the City/Parish shall notify EPA and LDEQ, in writing, within ten (10) business days. The notice shall indicate whether the City/Parish claims that the delay should be excused due to a Force Majeure event. The notice shall describe in detail the basis for the City/Parish's contention that they experienced a Force Majeure delay,

the anticipated length of the delay, the precise cause or causes of the delay, the measures taken or to be taken to prevent or minimize the delay, and the timetable by which those measures will be implemented. The City/Parish shall adopt all reasonable measures to avoid or minimize such delay. Failure to so notify EPA and LDEQ shall render this Section void and of no effect as to the event in question, and shall be a waiver of the City/Parish's right to obtain an extension of time for the obligations based on such event.

86. If EPA and LDEQ agree that the delay or anticipated delay is attributable to a force majeure event, the time for performance of the obligations under this consent Decree that are affected by the force majeure event will be extended by at least the amount of time lost due to the force majeure event. If EPA or LDEQ does not agree that the delay or anticipated delay has been or will be caused by a force majeure event, then the City/Parish will be notified in writing of this decision and the reasons for the decision. If EPA and LDEQ agree that the delay is attributable to a force majeure event, they will notify the City/Parish in writing of the length of the extension, if any, for performance of the obligations affected by the force majeure event.

87. If the City/Parish elects to invoke the dispute resolution procedure set forth in Section XXIV (Dispute Resolution) in connection with EPA's and/or LDEQ's decision that a delay or anticipated delay is not attributable to a force majeure event, it shall do so no later than fifteen (15) days after receipt of EPA and/or LDEQ's notice pursuant to Paragraph 86. In any such proceedings, the City/Parish shall have the burden of demonstrating by a preponderance of the evidence that the delay or anticipated delay has been or will be caused by a force majeure event, that the duration of the delay or the extension sought was or will be warranted under the circumstances, that best efforts were

exercised to avoid and mitigate the effects of the delay, and that the City/Parish complied with the requirements of Paragraphs 84 and 85. If the City/Parish carries this burden, the delay at issue shall be deemed not to be a violation by the City/Parish of this Consent Decree.

88. An extension of one compliance date based on a particular force majeure event shall not automatically extend any other compliance date. The City/Parish shall make an individual showing of proof regarding the cause of each delayed incremental step or other requirement for which an extension is sought.

XXIII. RETENTION OF JURISDICTION

89. This Court shall retain jurisdiction of this matter for the purposes of implementing and enforcing the terms and conditions of this Consent Decree and for the purpose of adjudicating all disputes among the parties that may arise under the provisions of this Consent Decree, to the extent that this Consent Decree provides for resolution of disputes by the Court.

XXIV. DISPUTE RESOLUTION

90. Unless otherwise expressly provided for in this Consent Decree, the dispute resolution procedures of this Section shall be the exclusive mechanism to resolve disputes arising under or with respect to this Consent Decree. However, the procedures set forth in this Section shall not apply to actions by the United States or the State of Louisiana to enforce obligations of the City/Parish that have not been disputed in accordance with this Section. Within thirty (30) days after a decision is issued by EPA or LDEQ under Section XVII (Review of Submittals), that decision shall be final and not

subject to dispute resolution unless the City/Parish has invoked dispute resolution pursuant to this Section prior to the expiration of the thirty (30) day period.

91. Any dispute which arises under or with respect to this Consent Decree shall in the first instance be the subject of good-faith informal negotiations between the parties to the dispute. In the case of a dispute regarding a decision by EPA or LDEQ regarding an item submitted for review and approval under Section XVII (Review of Submittals), the parties to the dispute shall be the City/Parish and the agency that issued the disputed decision. The goal of the informal negotiations shall be to resolve the dispute without further proceedings. The period for informal negotiations shall not exceed thirty (30) days from the time the dispute arises, unless (a) EPA or LDEQ (whichever is a party to the dispute), in their sole discretion, determines that a shorter period shall be allowed due to an immediate threat to the environment or (b) all parties to the dispute agree in writing to an extension. The dispute shall be considered to have arisen when the City/Parish sends Plaintiffs a written Notice of Dispute. The Notice of Dispute shall contain a concise statement of the issue or issues in dispute. If informal negotiations result in an agreement between the parties to the dispute, then those parties shall state the agreement in a single document in writing. If informal negotiations do not result in an agreement between the parties to the dispute, then the agency that issued the disputed decision shall provide to the City/Parish in writing its opinion on the disputed issue or issues.

92. A. If the parties to the dispute cannot resolve it by informal dispute resolution, then the position advanced by the agency that issued the disputed decision shall be considered binding unless, within fifteen (15) days after the

issuance of a written opinion under Paragraph 91 by the agency that issued the disputed decision, the City/Parish invokes the formal dispute resolution procedures of this Section by serving on the agency that issued the disputed decision a written Statement of Position on the matter in dispute. In its Statement of Position, the City/Parish shall describe the subject of the dispute, state its position on the dispute, and set forth in detail the basis for that position. The Statement of Position shall include the factual data, analysis, and opinions supporting the City/Parish's position and the supporting documentation relied upon by the City/Parish. The Statement of Position shall specify the City/Parish's position as to whether formal dispute resolution should proceed under Paragraph 93 or Paragraph 94.

B. Within fifteen (15) days after receipt of the City/Parish's Statement of Position, the agency that issued the disputed decision will serve on the City/Parish its Statement of Position. In its Statement of Position, that agency shall describe the subject of the dispute, state its position on the dispute, and set forth in detail the basis for that position. The Statement of Position shall include the factual data, analysis, and opinions supporting the agency's position and the supporting documentation relied upon by it. The Statement of Position shall specify the agency's position as to whether formal dispute resolution should proceed under Paragraph 93 or Paragraph 94.

C. Within seven (7) days after receipt of the Statement of Position by the agency that issued the disputed decision, the City/Parish may submit a Reply to that agency's Statement of Position.

D. If there is a disagreement between the parties to the dispute as to whether dispute resolution should proceed under paragraph 93 or 94, the parties to the dispute shall follow the procedures set forth in the Paragraph determined by the agency that issued the disputed decision to be applicable. However, after a decision is issued under Paragraph 93(c) or 94(a), if the City/Parish appeals the dispute to the Court for resolution under Paragraph 93(d) or 94(a), the Court shall determine which Paragraph is applicable in accordance with the standards of applicability set forth in Paragraphs 93 and 94.

93. the formal dispute resolution procedures set forth in this Paragraph shall apply to disputes pertaining to matters that are accorded review on the administrative record under applicable principles of administrative law. The provisions of this Paragraph shall apply, without limitation, to (1) disputes regarding items requiring approval by EPA and LDEQ under this Consent Decree including, but not limited to, disputes regarding the adequacy or appropriateness of and procedures to implement Work, and (2) disputes regarding the selection, evaluation, implementation, performance, or adequacy of any Work.

A. An administrative record of the dispute shall be maintained by the agency that issued the disputed decision and shall contain all Statements of Position submitted pursuant to Paragraph 92, including supporting documentation, submitted pursuant to this Section. Where appropriate, the agency that issued the disputed decision may allow submittal of supplemental statements of position by the parties to the dispute.

B. In a case where the disputed decision was issued by EPA, the Director of the Compliance Assurance and Enforcement Division for EPA Region 6 will issue a final administrative decision resolving the dispute based on the administrative record described in Subparagraph (A) above. In a case where the disputed decision was issued by LDEQ, the Secretary of the LDEQ will issue a final administrative decision resolving the dispute based on the administrative record described in Subparagraph (a) above. This decision shall be binding upon the City/Parish subject only to the right to seek judicial review pursuant to Subparagraphs (C) and (D).

C. Any administrative decision pursuant to Subparagraph (B) above shall be reviewable by this Court, provided that a motion for judicial review of the decision is filed by the City/Parish with the Court and served on all Parties within twenty (20) days of receipt of the decision. The motion shall include a description of the matter in dispute, the efforts made to resolve it, the relief requested, and the schedule, if any, within which the dispute must be resolved to ensure orderly implementation of this Consent Decree. Both EPA and LDEQ may file a response to the City/Parish's motion.

D. In proceedings on any dispute governed by this Paragraph, the City/Parish shall have the burden of demonstrating that the decision under subparagraph (B) above is arbitrary and capricious or otherwise not in accordance with law. Judicial review of decisions under Subparagraph (B) above shall be limited to the administrative record compiled pursuant to Subparagraph (A) above.

98. Formal dispute resolution for disputes that do not pertain to (1) the adequacy or appropriateness of and procedures to implement Work, (2) the selection, evaluation, implementation, performance, or adequacy of any Work; or (3) that are not otherwise accorded review on the administrative record under applicable principles of administrative law shall be governed by this Paragraph. The provisions of this Paragraph shall apply, without limitation to disputes arising under Section XXII (Force Majeure) regarding whether any failure by the City/Parish to meet a deadline was caused by a force majeure event.

A. In a case where the disputed decision was issued by EPA, the Director of the Compliance Assurance and Enforcement Division, EPA Region 6 will issue a final decision resolving the dispute. In a case where the disputed decision was issued by LDEQ, the Secretary of the LDEQ will issue a final decision resolving the dispute. Such decision shall be binding on the City/Parish unless, within twenty (20) days of receipt of the decision, the City/Parish files with the Court and serves on the other Parties a motion for judicial review of the decision setting forth the matter in dispute, the efforts made to resolve it, the relief requested, and the schedule, if any, within which the dispute must be resolved to ensure orderly implementation of the Consent Decree. Both EPA and LDEQ may file a response to the City/Parish's motion.

B. Judicial review of any dispute governed by this Paragraph shall be governed by applicable principles of law.

95. In the event of any re-organization of EPA which affects the Compliance Assurance and Enforcement Division for EPA Region 6 and/or any substantial change in

the responsibilities of the Director of the Compliance Assurance and Enforcement Division for EPA Region 6, EPA may notify the City/Parish that the authorities and responsibilities of the Director of the Compliance Assurance and Enforcement Division for EPA Region 6 will be transferred to an official specified in the notice.

96. Invocation of the dispute resolution procedures under this Section shall not extend, postpone or affect in any way any obligation of the City/Parish under this Consent Decree not directly in dispute, unless EPA and LDEQ agree otherwise or the Court so orders or directs.

XXV. RIGHT OF ENTRY

97. The United States and the State of Louisiana and their authorized representatives and contractors shall have authority at all times, upon the presentation of credentials, to enter the premises and/or worksite of the City/Parish to:

- A. Monitor the progress of activities required by this Consent Decree;
- B. Verify any data or information submitted to the United States or the State of Louisiana;
- C. Obtain samples, and, upon request, obtain splits of any samples collected by the City/Parish or their consultants and contractors;
- D. Inspect and evaluate any portions of the North, Central, or South Plants and related Collection Systems; and
- E. Inspect and review any records required to be kept under the terms and conditions of this Consent Decree, applicable ~~NPDES/LPDES~~ Permits, or the CWA.

Deleted: NPDES

These inspection rights are in addition to, and in no way limit or otherwise affect, the United States' and the State of Louisiana's statutory authorities to conduct inspections, to require monitoring, and to obtain information from the City/Parish as authorized by law

**XXVI. NOT A PERMIT/COMPLIANCE WITH OTHER
STATUTES/REGULATIONS**

98. This Consent Decree is not and shall not be construed as a permit issued pursuant to CWA Section 402, 33 U.S.C. § 1342, nor as a modification of any existing permit so issued, nor shall it in any way relieve the City/Parish of their obligations to obtain and maintain NPDES/LPDES permits for the North, Central, and South Plant or any other part of their wastewater treatment and collection system or facilities and to comply with the requirements of any NPDES/LPDES permit; Section XVI (Interim Effluent Limits), if applicable; and any other applicable federal or state law or regulation. Any new permit, or modification of existing permits, must be complied with in accordance with applicable federal and state laws and regulations.

99. Nothing here shall be construed as relieving the City/Parish of the duty to comply with the CWA, regulations promulgated under the CWA, and all permits issued under the CWA (except as specifically provided in Section XVI (Interim Effluent Limits)).

100. This Consent Decree shall not be construed as a ruling or determination of any issue related to any federal, state, or local permit required in order to implement this Consent Decree or required to continue operation of the North, South, and Central plants and related Collection Systems. The City/Parish shall be responsible for obtaining any federal, state, or local permit(s) required for Work under this Consent Decree.

XXVII. FAILURE OF COMPLIANCE

101. The United States does not, by its consent to the entry of this Consent Decree, warrant or aver in any manner that the City/Parish's complete compliance with this Consent Decree will result in compliance with the provisions of the Clean Water Act, 33 U.S.C. §§ 1251 et seq., or with the City/Parish's NPDES/LPDES permits.

Deleted: NPDES

Notwithstanding EPA's review or approval of any plans, reports, policies, or procedures formulated pursuant to this Consent Decree, the City/Parish shall remain solely responsible for any non-compliance with the terms of this Consent Decree, all applicable permits, the CWA and regulations promulgated under the CWA. The pendency or outcome of any proceeding concerning issuance, re-issuance, or modifications of any permit shall neither affect nor postpone the City/Parish's duties and obligations as set forth in this Consent Decree.

XXVIII. NON-WAIVER PROVISIONS

102. This Consent Decree in no way affects or relieves the City/Parish of any responsibility to comply with any federal, state, or local law or regulation. However, nothing in this Paragraph shall be deemed to conflict with the provisions of Section XVI (Interim Effluent Limits).

103. The parties agree that the City/Parish is responsible for achieving and maintaining complete compliance with all applicable federal and state laws, regulations, and permits, and that compliance with this Consent Decree shall be no defense to any actions commenced pursuant to said laws, regulations, or permits, except as otherwise expressly specified in the Consent Decree.

104. This Consent Decree does not limit or affect the rights of the City/Parish, the United States, or the State of Louisiana as against any third parties that are not parties to this Consent Decree.

105. The Parties reserve any and all legal and equitable remedies available to enforce the provisions of this Consent Decree.

106. Except as expressly provided herein, Plaintiffs hereby reserve all statutory and regulatory powers, authorities, rights, and remedies (including all such legal, equitable, civil, criminal, and administrative powers), including, without limitation, those that may pertain to the City/Parish's failure to comply with any of the requirements of this Consent Decree, the CWA, or state law. Such powers, authorities, rights, and remedies shall include, without limitation, additional enforcement action and the assessment of penalties under the CWA against the City/Parish, the authority to seek information from the City/Parish, and the authority to seek access to the property of the City/Parish.

107. Performance of the terms of this Consent Decree by the City/Parish is not conditioned on the receipt of any federal or state funds.

108. Obligations of the City/Parish under the provisions of this Consent Decree to perform Work scheduled to occur after the Date of Lodging, but prior to the Date of Entry, shall be legal enforceable from the Date of Lodging of this Consent Decree. Liability for stipulated penalties for any such obligations shall not begin to accrue until the date of Entry of this Consent Decree. Obligations in the Consent Decree, unless otherwise stated, shall be initiated upon Entry of the Consent Decree.

109. It is the intent of the Parties hereto that the clauses hereof are severable, and should any clause(s) be declared by a court of competent jurisdiction to be invalid and unenforceable, the remaining clauses shall remain in full force and effect.

XXIX. COVENANT NOT TO SUE BY THE UNITED STATES AND THE STATE OF LOUISIANA

110. In consideration of the actions that will be performed under the terms of this Consent Decree by the City/Parish and the payments that the City/Parish will make pursuant to Paragraphs 55 (Civil Penalty) and 66 (Past Stipulated Penalties) and except as otherwise specifically provided in this Consent Decree, the United States covenants not to sue or to take administrative action against the City/Parish for civil claims specifically alleged in the Complaint which accrue on or before the Date of Entry. In consideration of the actions that will be performed under the terms of this Consent Decree by the City/Parish and the payment that the City/Parish will make pursuant to Paragraph 55 (Civil Penalty) and except as otherwise specifically provided in this Consent Decree, the State of Louisiana covenants not to sue or to take administrative action against the City/Parish for civil claims specifically alleged in the Complaint which accrue on or before the Date of Entry and for the following civil claims which accrue on or before the Date of Entry:

- Civil claims against the City/Parish for Unauthorized Discharges from the Collection System pursuant to LA. R.S. 30:2075;
- Civil claims against the City/Parish for violations of NPDES/LPDES Permits Nos. LA0036412, LA0036421, and LA0036439 pursuant to LA. R.S. 30:2076(A); and
- Civil claims against the Parish for discharges without a permit from the North, Central, and South Plants pursuant to LA. R.S. 30:2075.

This covenant not to sue is conditioned upon satisfactory performance by the City/Parish of its obligations under this Consent Decree. This covenant not to sue shall take effect upon the receipt by the United States and the State of Louisiana of the full payment required by Paragraphs 55 (Civil Penalty) and Paragraph 66 (Past Stipulated Penalties). This covenant not to sue extends only to the City/Parish and does not extend to any other person.

111. Except as specifically provided in Section XVI (Interim Effluent Limits), the United States and the State of Louisiana reserve all remedies available to it for violations of the CWA by the City/Parish which are not alleged in the Complaints and for violations of the CWA by the City/Parish which occur after the Date of Lodging of this Consent Decree.

112. This Consent Decree does not resolve criminal liability, if any, that any person might have for violations of the Clean Water Act.

113. Nothing in this Consent Decree shall be construed to limit the authority of the United States or the State of Louisiana to undertake any action against any person, including the City/Parish, in response to conditions that may present an imminent and substantial endangerment to the environment or to the public health or welfare.

XXX. ENDANGERMENT

114. If EPA or LDEQ determine that any activities undertaken pursuant to this Consent Decree have caused or may cause an imminent and substantial risk of harm to the public health or the environment, either Agency may order the City/Parish to (1) stop immediately any specified activities under this Consent Decree for such period of time as may be needed to abate any such risk and (2) undertake any action which EPA or LDEQ

determines is necessary to abate such release or threat. Relevant schedules affected by the work stoppage shall be extended by any period during which implementation is stopped by order of EPA or LDEQ plus any reasonable demobilization and/or re-mobilization periods, provided that the release or threat is not due to noncompliance by the City/Parish with this Consent Decree.

XXXI. COSTS OF SUIT

115. Each party shall bear its own costs and attorney's fees with respect to matters resolved by this Consent Decree. Should the City/Parish subsequently be determined by the Court to have violated the terms and conditions of this Consent Decree, the City/Parish shall be liable to the United States for any expenses and attorney's fees incurred by the United States in actions against the City/parish to enforce the requirements of this Consent Decree. Attorneys fees shall be allowable at the maximum rate permitted under 28 U.S.C. § 2412(d)(2)(A)(ii) without a finding of special factors.

XXXII. RECORD KEEPING

116. The City/Parish shall maintain copies of any underlying research and data for any and all documents, reports, or permits submitted to EPA and LDEQ pursuant to this Consent Decree which are in the possession, custody or control of the City/Parish or its agents, contractors, subcontractors, officers, servants, employees, attorneys, successors, or assigns for a period of three (3) years from date of submission. The City/Parish shall submit such supporting documents to EPA upon request.

XXXIII. FORM OF NOTICE

117. Unless otherwise specified, all reports, notices, or any other written communications required to be submitted under this Consent Decree shall be sent to the respective parties at the following addresses:

As to the United States:

Chief
Environmental Enforcement Section
Environment and Natural Resources Division
U.S. Department of Justice
P.O. Box 7611
Washington, D.C. 20044-7611

Street Address (No USPS delivery)

1425 N Y. Ave., NW, 13th Floor
Washington, D.C. 20005

Chief, Water Enforcement Branch (6EN-W)
Compliance Assurance and Enforcement Division
U.S. Environmental Protection Agency, Region VI
1445 Ross Avenue
Dallas, Texas 75202-2733

As to EPA:

Chief, Water Enforcement Branch (6EN-W)
Compliance Assurance and Enforcement Division
U.S. Environmental Protection Agency, Region VI
1445 Ross Avenue
Dallas, Texas 75202-2733

As to LDEQ:

Administrator
Office of Environmental Compliance
Louisiana Department of Environmental Quality
P.O. Box 4312
Baton Rouge, LA 70821-4312

Deleted: Bruce Hammatt

Deleted: 82215

Deleted: 84-2215

Street Address:

521 N. Fifth Street
Galvez Building
Baton Rouge, LA 70802

Deleted: 7290 Bluebonnet Rd

Deleted:

Deleted: LDEQ

Deleted: I

Deleted: -1611

Deleted: Fred E. Rainford, III

As to City/Parish:

Director
Department of Public Works

City of Baton Rouge
Parish of East Baton Rouge
Post Office Box 1471
Baton Rouge, Louisiana 70821

Street Address:
300 North Boulevard, Rm. 208
Old Municipal Building
Baton Rouge, Louisiana 70802

Notifications to or communications, if received, shall be deemed submitted on the date they are postmarked and sent by certified mail, return receipt requested or, when sent by non-postal delivery, the date of pickup provided same is for next day delivery.

XXXIV. MODIFICATION

118. Schedules for completion of the Work, except the deadline for completion of the Collection System Remedial Program set pursuant to Paragraphs 34(D) and 34A(D), may be modified by agreement of EPA, LDEQ, and the City/Parish. All such modifications shall be made in writing.

119. Material modifications may be made to this Consent Decree only with written notification to and written approval of each of the Parties and the Court and with an opportunity for public notice and comment in a manner consistent with Paragraphs 122 and 123. Modifications to attachments or exhibits to this Consent Decree that do not materially alter that document may be made by written agreement between the United States, LDEQ and the City/Parish.

120. Nothing in this Consent Decree shall be deemed to alter the Court's power to enforce, supervise, or approve modifications to this Consent Decree.

XXXV. CONTINGENT LIABILITY OF STATE OF LOUISIANA

121. This Consent Decree does not resolve the contingent liability of the State of Louisiana under Section 309(e) of the Act, 33 U.S.C. § 1319(e). The United States specifically reserves its claims against the State, and the State reserves its defenses.

XXXVI. PUBLIC COMMENT AND ENTRY

122. After this Consent Decree has been signed by all Parties, it shall be lodged with the Court for a period of not less than thirty (3) days for public notice and comment in accordance with U.S. Department of Justice Policy and 28 C.F.R. § 50.7. The United States reserves the right to withdraw or withhold its consent if comments by the public regarding the Consent Decree disclose facts or considerations which indicate that the Consent Decree is inappropriate, improper, or inadequate. This Paragraph does not create any rights exercisable by the City/Parish.

123. The Parties agree and acknowledge that final approval by Plaintiff the State of Louisiana, Department of Environmental Quality, and entry of this consent Decree is subject to the requirements of La. R.S. 30:2050.7, which provides for public notice of this Consent Decree in newspapers of general circulation and the official journals of the Parish of East Baton Rouge, and opportunity for public comment, consideration of any comments, and concurrence by the State Attorney General. This Paragraph does not create any rights exercisable by the City/Parish.

124. By the signature of its authorized representative below, the City/Parish agrees to entry of this Consent Decree without further notice.

XXXVII. THE 1988 CONSENT DECREE

125. This Consent Decree is intended to supercede and replace the December 23, 1988 Modified Consent Decree (“the 1988 Consent Decree”) in United States v.

Baton Rouge, No. 88-191A (M.D. La.) Accordingly, the 1988 Consent Decree is terminated as of the Effective Date of this Consent Decree.

XXXVIII. TERMINATION

126. The Consent Decree shall remain in effect until terminated by the Court pursuant to a Motion for Termination filed by a Party. As a requirement of termination, the City/Parish shall have the burden to demonstrate the following items:

A. The remedial measures set forth in the First and Second RMAPs have been completed and are fully operational;

B. All SEPs have been completed in compliance with all applicable requirements;

C. There have been no Non-Compliant Discharges from the North Plant during any twelve (12) month period following the completion of construction of all elements of the Collection System Remedial Program related to the North Plant and its Collection System;

D. There have been no Non-Compliant Discharges from the Central Plant during any twelve (12) month period following the completion of construction of all elements of the Collection System Remedial Program related to the Central Plant and its Collection System;

E. There have been no Non-Compliant Discharges from the South Plant during any twelve (12) month period following the completion of construction of all elements of the Collection System Remedial Program related to the South Plant and its Collection System;

F. The City/Parish has paid all civil penalties, costs, damages, stipulated penalties, and other sums due under this Consent Decree; and

G. The City/Parish has fulfilled all other obligations under this Consent Decree and been in compliance with all other requirements of this Consent Decree during the preceding six months.

If the condition set forth in Subparagraphs (C), (D), and/or (E) has not been met, the City/Parish may still file a Motion for Termination; however, if EPA or LDEQ, in their sole discretion, objects to termination based upon the City/Parish's failure to meet the condition set forth in Subparagraphs (C), (D), and/or (E), then the Court shall deny termination until all the conditions specified have been met. The United States and the State of Louisiana shall have the opportunity to file a response to any motion filed by the City/Parish for termination of this Consent Decree.

XXXIX. SIGNATORIES

127. The Assistant Attorney General on behalf of the United States and the undersigned representatives of the City/Parish and the State of Louisiana certify that they are fully authorized to enter into the terms and conditions of this Consent Decree and to execute and legally bind such party to this document.

Entered this _____ day of _____, 2005.

Deleted: 14th
Deleted: March
Deleted: 1

United States District Judge

FOR THE UNITED STATES OF AMERICA:

November 22, 2001

Date

JOHN C. CRUDEN ?
Acting Assistant Attorney General
Environment and Natural Resources Division
United States Department of Justice

Formatted: Highlight

October 4, 2001

Date

MICHAEL T. DONNELLAN
Senior Attorney
Environmental Enforcement Section
Environment and Natural Resources Division
United States Department of Justice
P.O. Box 7611
Washington, D.C. 20044
(202) 514-4226

DAVID R. DUGAS
United States Attorney
Middle District of Louisiana

November 13, 2001

Date

JOHN J. GAUPP, LA. Bar Roll No. 14976
Assistant United States Attorney
Middle District of Louisiana
777 Florida St., Suite 208
Baton Rouge, Louisiana 70801
(225) 389-0443

FOR THE ENVIRONMENTAL PROTECTION AGENCY:

November 2, 2001
Date

SYLVIA LOWRANCE
Acting Assistant Administrator
Office of Enforcement and Compliance Assurance
United States Environmental Protection Agency
Washington, D.C. 20460

November 6, 2001
Date

GREGG A. COOKE
Regional Administrator
U.S. Environmental Protection Agency, Region 6
1445 Ross Avenue
Dallas, Texas 75202-2733

November 6, 2001
Date

CARLOS A. ZEQUEIRA
Enforcement Counsel
U.S. Environmental Protection Agency, Region 6
1445 Ross Avenue
Dallas, Texas 75202-2733

OF COUNSEL:

ELYSE DIBIAGIO-WOOD
Attorney/Advisor
Office of Regulatory Enforcement
United States Environmental Protection Agency
1200 Pennsylvania Ave., NW
Washington, D.C. 20460

PRELIMINARILY:

FOR THE STATE OF LOUISIANA, THROUGH THE DEPARTMENT OF ENVIRONMENTAL QUALITY:

August 30, 2001

Date

Harold Leggett
Assistance Secretary
Office of Environmental Compliance
Louisiana Department of Environmental Quality

Deleted: LINDA KORN LEVY

August 30, 2001

Date

Ted Broyles
Legal Division
Louisiana Department of Environmental Quality
P.O. Box _____
Baton Rouge, Louisiana 70821

Deleted: JOHN B. KING

Deleted: Chief Attorney

Deleted: 82282

Deleted: 84

Deleted: 2282

FOR THE CITY OF BATON ROUGE AND THE PARISH OF EAST BATON ROUGE:

Date

Melvin Holden
Mayor-President
City of Baton Rouge, Louisiana
Parish of East Baton Rouge, Louisiana
222 St. Louis Street
Baton Rouge, Louisiana 70802

Deleted: September 26, 2001

Deleted: Bobby Simpson

Consent Decree Collection System Remedial Program Revised Second Remedial Action Plan (RMAP2) Projects

These descriptions are to provide general information about the type of work to be completed for each project, as identified through hydraulic computer modeling. It is anticipated that, during engineering and design, the project details may change due to site constraints or optimization of the design; however, the overall program objectives will be met and the final consent decree deadline will be achieved. Particular basins are identified herein based upon best available flow monitoring and modeling information available at time of Revised RMAP2 development. As additional data become available and field conditions are confirmed, the specific basins for rehabilitation and pipe and pump size changes maybe updated.

Project Descriptions, Schedule and Preliminary Opinion of Probable Construction Cost

The projects are separated into three categories, with description of the projects, schedule and preliminary opinion of probable construction cost for each project provided. Following the project descriptions, the funding method is described.

Category 1: Comprehensive Sewer Basin Rehabilitation and Pump Station Upgrades

Based upon sewer system model results and flow monitoring, numerous basins within the Baton Rouge system require comprehensive rehabilitation. The basins identified through the system model are scheduled for rehabilitation based upon the modeled R-values.

Improvements to pump stations to allow them to pump into the system will be required at a number of pump stations. The improvements by service area are:

North CSD/STN Area

- Asses and potentially perform mechanical upgrades at 43 pump stations.

Central CSD Area

- Asses and potentially perform mechanical upgrades at 3 pump stations.

South CSD/STN Area

- Asses and potentially perform mechanical upgrades at 41 pump stations.

These Category 1 projects are listed below along with the projected start construction and complete construction dates. Field work is scheduled to commence immediately

upon acceptance of this Revised RMAP2 by EPA and DEQ. Seven project groups scheduled for immediate rehabilitation have been identified as follows.

Project Group	Approximate Footage Per Project Group	Preliminary Opinion of Probable Construction Cost	Start Construction	Complete Construction	Fully Operational
CSR-01	80,000	\$7,000,000	March 2006	March 2007	October 2007
CSR-02	150,000	\$14,100,000	June 2006	May 2008	December 2008
CSR-03	150,000	\$14,100,000	August 2006	August 2008	March 2009
CSR-04	150,000	\$14,000,000	November 2006	November 2008	June 2009
CSR-05	150,000	\$14,000,000	February 2007	February 2009	September 2009

* Preliminary Opinion of Probable Construction Cost includes Contingency, Engineering, Administration, and Legal costs.

The remaining sewer basins identified as requiring rehabilitation because of the R-value will be separated into projects ranging with construction costs of between \$3 million and \$5 million per project.

The schedule for implementation and the preliminary opinion of probable construction cost for the remaining rehabilitation projects and pump station mechanical improvements are included in the table below.

Project	Preliminary Opinion of Probable Construction Cost	Start Construction	Complete Construction	Fully Operational
Comprehensive Rehabilitation	\$106,700,000	March 2007	August 2013	March 2014
Pump Station Improvements	\$29,200,000	January 2007	September 2008	December 2008

* Preliminary Opinion of Probable Construction Cost includes Contingency, Engineering, Administration, and Legal costs.

Category 2: Pump Station and Transmission Improvements

The system model was used to identify pump stations where existing pump head is not adequate to pump against the system and to identify pump stations and conveyance lines where capacity is not adequate for the peak wastewater flows. Based upon this analysis, two project groups have been developed. The schedule for implementation is provided below.

Project	Preliminary Opinion of Probable Construction Cost	Start Construction	Complete Construction	Fully Operational
Capacity Improvements	\$233,756,000	August 2010	July 2014	November 2014

* Preliminary Opinion of Probable Construction Cost includes Contingency, Engineering, Administration, and Legal costs.

The Category 2 improvements are identified by service area below.

North CSD/STN Area

PS106/155/198/181 Areas

- Replace approximately 2,000 LF of gravity sewer in PS155 area and 3800 LF of gravity sewer in remaining pump station areas.

Area Upstream of PS509

- Make capacity upgrades to PS234, PS500, and PS218.
- Replace approximately 7,400 LF of force main in PS509, PS72, PS234, and PS103 areas.
- Replace approximately 300 LF of gravity sewer.

Area Upstream of PS510

- Make capacity upgrade to PS113.
- Replace approximately 15,600 LF of force main.
- Replace approximately 1,100 LF of gravity sewer.

Area Upstream of PS511

- Make capacity upgrade to PS230, PS231, and PS196.
- Replace approximately 7,700 LF of force main.
- Replace approximately 3,000 LF of gravity sewer.

Area Upstream of PS503

- Make capacity upgrade to PS183.
- Replace approximately 5,300 LF of gravity sewer and parallel approximately 1,450 LF of gravity sewer.

Area Upstream of PS897

- Make capacity upgrade to PS94.
- Replace approximately 3,600 LF of force main.
- Replace approximately 650 LF of gravity sewer.

Area Upstream of PS45

- Make capacity upgrade to PS45, PS63, PS240, PS241 and PS80
- Replace approximately 2,600 LF of force main in the PS45 and PS63 areas.
- Replace approximately 5,300 LF of gravity sewer and parallel approximately 22,000 LF of gravity sewer.

North Pressure System

- Make capacity upgrade to PS39.
- Replace approximately 2,400 LF of force main in PS141, PS47, and PS39 areas.
- Replace approximately 14,000 LF of gravity sewer and parallel approximately 13,200 LF of gravity sewer.

North WWTP Gravity Influent Line

- Make capacity upgrade to PS23
- Replace approximately 1,400 LF of force main in PS23 area
- Replace approximately 5,700 LF of gravity sewer and parallel approximately 28,000 gravity sewer.

Central CSD Area

Area South of I-10/Downtown

- Make capacity upgrade to PS2
- Parallel approximately 13,000 LF gravity sewer and replace approximately 9,000 LF of gravity sewer

Area North of I-10/Downtown and Capital Area

- Make capacity upgrade to PS4.
- Assess and make possible mechanical upgrades to PS5, PS15, and PS19
- Replace approximately 8,000 LF of gravity sewer and parallel approximately 17,000 LF of gravity sewer.

South CSD/STN Area

Area North of I-12 at Sherwood Forrest to Airline Highway

- Make capacity upgrades to PS50, PS53, PS57 and PS 58 including new parallel force main.
- Replace approximately 14,000 LF of gravity sewer and install approximately 81,000 LF of parallel gravity sewer in PS58 area.
- Replace approximately 26,000 LF gravity sewer and install approximately 34,000 LF of parallel gravity sewer.
- Replace approximately 2,500 LF of force main.

Area Upstream of PS889

- Replace approximately 7,800 LF of gravity sewer.

- Replace approximately 9,000 LF of force main and install approximately 200 LF of parallel force main.
- Make capacity improvements at PS153, PS100, PS189, PS889 and PS104.

Area Upstream of BPS514/East of Highland Road

- Make significant capacity upgrade to PS514.
- Replace approximately 3,000 LF of gravity sewer and parallel approximately 2,800 LF of gravity sewer.
- Assess and potentially make capacity improvements to PS327, PS253, PS278, PS382, and PS343.

O'Neal Lane South Area

- Assess and potentially make capacity improvements to PS316, PS211, PS296, PS247, and PS213.
- Replace approximately 5,000 LF of gravity sewer.
- Replace approximately 3,000 LF of force main.

Area Upstream of BPS507

- Assess and make potential capacity improvements to PS162, PS177, PS274, and PS170.
- Make significant capacity improvements to PS777.
- Replace approximately 20,000 LF of gravity sewer and parallel over 1,100 LF of gravity sewer.
- Replace approximately 1,600 LF of force main and parallel approximately 100 LF of force main.

Area South of I-12/Sherwood Forrest and Jefferson

- Make capacity improvements to PS287
- Replace approximately 1,800 LF of gravity sewer and install approximately 600 LF of parallel gravity sewer.
- Replace approximately 1,100 LF of force main.

Areas Upstream of PS302/PS27/PS999

- Make significant capacity improvements to PS999.
- Inspect and potentially make capacity improvements to PS223, PS118, and PS161.
- Replace approximately 5,600 LF of gravity sewer.

Essen Lane Area South of I-10

- Make significant capacity improvements to PS57, PS58, and PS53.
- Make capacity improvements at PS56, PS68, and PS91.
- Replace approximately 38,000 LF of gravity sewer and parallel approximately 109,000 LF of gravity sewer.
- Replace approximately 700 LF of force main and parallel approximately 5,100 LF of force main.

PS236, PS311, PS329, PS102

- Make capacity improvements to PS236, PS311, and PS329
- Replace approximately 9,300 LF of gravity sewer.
- Replace approximately 2,200 LF of force main.

Category 3: Wastewater Treatment and Flow Equalization

The system model was used to determine the peak wastewater flow expected at each treatment plant. The South Wastewater Treatment Plant was identified as requiring improvements to provide for a peak flow of 300 million gallons per day (MGD). This peak flow will be managed through construction of a 24 million gallon flow equalization facility. A new headworks facility sized for 300 MGD will be provided to screen the wastewater prior to entering the flow equalization facility or being pumped to the South WWTP by a new 200 MGD pump station. The flow equalization facility, headworks and pump station are provided in Project WWTP-01.

The South WWTP capacity will be increased to 200 MGD and process modifications will be made to convert the plant from a trickling filter facility to an activated sludge treatment facility. This process modification will provide for increased ability to comply with discharge permit limitations. These improvements are provided in Project WWTP-03.

Piping from the new headworks/flow equalization facility to the existing South WWTP and piping from the South WWTP to the discharge point in the Mississippi River are also provided as Projects WWTP-02 and WWTP-04, respectively.

The schedule for construction and the Preliminary Opinion of Probable Construction Cost are provided below.

Project	Preliminary Opinion of Probable Construction Cost	Start Construction	Complete Construction	Fully Operational
Project WWTP-01: Headworks and Flow Equalization	\$29,530,000	May 2008	May 2011	August 2011
Project WWTP-02: Pipeline to South WWTP	\$2,940,000	August 2008	August 2009	December 2009
Project WWTP-03: South WWTP	\$33,030,000	April 2008	April 2011	August 2011

Upgrade				
Project WWTP-04: Pipeline to Mississippi River	\$2,500,000	April 2008	August 2009	December 2009

- Preliminary Opinion of Probable Construction Cost includes Contingency, Engineering, Administration, and Legal costs.

Personnel and Training for Implementation of Remedial Actions

The process for evaluating and providing personnel and training for successful implementation of the remedial actions is provided below as required by the Consent Decree.

Category 1: Comprehensive Sewer Basin Rehabilitation

The Category 1 improvement projects do not require additional personnel or training for implementation because the City/Parish currently operates the collection system. The collection system staff may be reduced once overflows, blockages, and system maintenance decreases as a result of improvements to the system. Crew call-outs for emergency line repairs should be significantly reduced.

These improvements make no changes to the existing system requiring modification to the current Standard Operating Procedure. Current training and staff are adequate to meet the needs of the remedial actions included in Category 1 improvements.

Category 2: Pump Station and Transmission Improvements and Pump Station Upgrades

The Category 2 improvement projects do not require additional personnel or training for implementation because the City/Parish currently operates the pump station and conveyance systems. These improvements make no changes to the existing system requiring modification to the current Standard Operating Procedure. Current training and staff are adequate to meet the needs of the remedial actions included in Category 2 improvements.

Category 3: Wastewater Treatment and Flow Equalization

The Category 3 improvement projects will require a shift of personnel to provide adequate staff at the new headworks and flow equalization facility. It is currently anticipated that two staff from the existing treatment plants can be transferred to the new headworks and flow equalization facility and no additional staff will be required.

Additional training regarding the operation of an activated sludge treatment process as well as training regarding the operation and maintenance of the new flow equalization facility, headworks and pump station will be required. This training will be provided during the construction of the new facilities. It is anticipated 6 classroom sessions will be required per employee and up to 80 hours of on-the-job training. The remaining classroom training will be provided by Louisiana licensed wastewater treatment plant operators and/or engineers.

Appendix C
Sub-basin R-values

<i>PRIME LP</i>	<i>Sub-basin ID</i>	<i>Existing Condition R-Value</i>	<i>Service Area</i>
052-00583	0520583	0.682	North
047-00428	0470428	0.610	North
046-00068	0460068	0.476	North
044-00609	0440609	0.434	North
046-00073	0460073	0.316	North
052-00490	0520490	0.290	North
052-00454	0520454	0.290	North
052-00145	0520145	0.290	North
048-00015	0480015	0.259	SCSD
044-00122	0440122	0.250	North
046-00178	0460178	0.240	North
046-00180	0460180	0.240	North
002-01283	0021283	0.233	CCSD
052-00168	0520168	0.229	North
002-01275	0021275	0.224	CCSD
052-00161	0520161	0.220	North
052-00204A	0520204A	0.220	North
050-00901	0500901	0.220	SCSD
052-00171	0520171	0.220	North
052-00209	0520209	0.220	North
059-06139	0596139	0.217	CCSD
052-00564	0520564	0.210	North
052-00553	0520553	0.210	North
282-00010	2820010	0.210	North
282-00002	2820002	0.210	North
052-00533	0520533	0.210	North
052-00784	0520784	0.210	North
127-00015E	1270015E	0.200	North
044-00587	0440587	0.199	North
044-00594	0440594	0.197	North
244-00007	2440007	0.192	North
244-00001	2440001	0.191	North
052-00061	0520061	0.190	North
052-00071	0520071	0.190	North
052-00006	0520006	0.190	North
052-00025	0520025	0.187	North
052-00019	0520019	0.186	North
052-00052	0520052	0.186	North
054-00069	0540069	0.181	North
052-00404	0520404	0.181	North
052-00115	0520115	0.180	North
044-00491	0440491	0.180	North
048-00235	0480235	0.180	SCSD
048-00225	0480225	0.180	SCSD
054-00009	0540009	0.180	North
060-07029	0607029	0.180	CCSD
060-06986	0606986	0.179	CCSD
052-00400	0520400	0.179	North
054-00028	0540028	0.177	North

*Appendix C
Sub-basin R-values*

<i>PRIMELP</i>	<i>Sub-basin ID</i>	<i>Existing Condition R-Value</i>	<i>Service Area</i>
059-06540	0596540	0.176	CCSD
044-00540	0440540	0.176	North
052-00728	0520728	0.170	North
052-00716	0520716	0.170	North
059-06016	0596016	0.168	CCSD
010-04974	0104974	0.168	CCSD
059-06484	0596484	0.168	CCSD
059-06445	0596445	0.168	CCSD
054-00062	0540062	0.168	North
010-04902	0104902	0.168	CCSD
059-06503	0596503	0.168	CCSD
059-06574	0596574	0.168	CCSD
059-06119	0596119	0.168	CCSD
010-04945	0104945	0.168	CCSD
010-04900	0104900	0.168	CCSD
060-07411	0607411	0.165	CCSD
059-06128	0596128	0.163	CCSD
050-00322	0500322	0.160	SCSD
059-06236	0596236	0.159	CCSD
044-00209	0440209	0.158	North
044-00400	0440400	0.157	North
059-06045	0596045	0.152	CCSD
052-00314	0520314	0.151	North
052-00246	0520246	0.151	North
050-00605	0500605	0.150	SCSD
050-00520A	0500520C	0.150	SCSD
050-00559	0500559	0.150	SCSD
050-00555	0500555	0.150	SCSD
050-00813	0500813	0.150	SCSD
050-00841	0500841	0.150	SCSD
050-00587	0500587	0.150	SCSD
050-00485	0500485	0.149	SCSD
059-06172	0596172	0.148	CCSD
059-06357	0596357	0.148	CCSD
059-06396	0596396	0.148	CCSD
059-06177	0596177	0.148	CCSD
124-00003	1240003	0.145	North
046-00219	0460219	0.145	North
044-00126	0440126	0.144	North
059-05874B	0595874B	0.144	CCSD
059-06198	0596198	0.144	CCSD
059-06184	0596184	0.144	CCSD
001-00586	0010586	0.144	CCSD
049-00119	0490119	0.144	SCSD
059-06197B	0596197B	0.143	CCSD
060-07898	0607898	0.143	CCSD
060-07867A	0607867A	0.142	CCSD
046-00059C	0460059C	0.142	North
236-00085	2360085	0.142	SSTN

Appendix C
Sub-basin R-values

<i>PRIMELP</i>	<i>Sub-basin ID</i>	<i>Existing Condition R-Value</i>	<i>Service Area</i>
060-07744	0607744	0.142	CCSD
060-07766	0607766	0.142	CCSD
236-00064	2360064	0.142	SSTN
060-07855	0607855	0.142	CCSD
059-05870	0595870	0.141	CCSD
050-00684	0500684	0.140	SCSD
040-00012	0400012	0.140	SCSD
049-00307	0490307	0.140	SCSD
052-00240	0520240	0.140	North
023-00028	0230028	0.140	North
044-00412	0440412	0.139	North
049-00295	0490295	0.139	SCSD
001-00700	0010700	0.139	CCSD
001-00652	0010652	0.139	CCSD
050-00713	0500713	0.139	SCSD
060-07057	0607057	0.136	CCSD
060-07972B	0607972B	0.136	CCSD
060-06962	0606962	0.135	CCSD
059-05879	0595879	0.134	CCSD
059-06059	0596059	0.133	CCSD
001-00562	0010562	0.133	CCSD
059-05861	0595861	0.131	CCSD
059-06267	0596267	0.131	CCSD
055-00001	0550001	0.131	North
047-00496	0470496	0.130	North
003-01786	0031786	0.130	CCSD
047-00469	0470469	0.130	North
002-01363	0021363	0.130	CCSD
055-00033	0550033	0.130	North
052-00833	0520833	0.130	North
054-00001A	0540001A	0.130	North
170-00077	1700077	0.130	SSTN
002-01307	0021307	0.130	CCSD
047-00474	0470474	0.130	North
052-00764	0520764	0.130	North
170-00040	1700040	0.130	SSTN
055-00105B	0550105B	0.130	North
092-00007	0920007	0.130	North
055-00030	0550030	0.130	North
170-00037	1700037	0.129	SSTN
052-00882	0520882	0.129	North
240-00011	2400011	0.127	North
052-00756	0520756	0.127	North
049-00040	0490040	0.125	SCSD
049-00006	0490006	0.125	SCSD
044-00274	0440274	0.125	North
049-00010	0490010	0.125	SCSD
049-00003	0490003	0.125	SCSD
044-00342	0440342	0.125	North

Appendix C
Sub-basin R-values

<i>PRIMELP</i>	<i>Sub-basin ID</i>	<i>Existing Condition R-Value</i>	<i>Service Area</i>
046-00012	0460012	0.125	North
052-00284	0520284	0.121	North
060-06964	0606964	0.120	CCSD
048-00133	0480133	0.120	SCSD
050-00629	0500629	0.120	SCSD
035-00002	0350002	0.120	North
048-00147	0480147	0.120	SCSD
050-00964	0500964	0.120	SCSD
043-00085	0430085	0.120	North
039-00003	0390003	0.120	North
035-00084	0350084	0.120	North
052-00264	0520264	0.120	North
035-00030	0350030	0.120	North
052-00324	0520324	0.120	North
039-00080	0390080	0.119	North
046-00318	0460318	0.119	North
047-00336	0470336	0.118	North
059-06290	0596290	0.117	CCSD
059-06651	0596651	0.116	CCSD
049-00221	0490221	0.115	SCSD
003-02128	0032128	0.115	CCSD
003-02249	0032249	0.115	CCSD
003-02087	0032087	0.115	CCSD
003-02160C	0032160C	0.115	CCSD
003-02235	0032235	0.115	CCSD
003-02204	0032204	0.115	CCSD
003-02039	0032039	0.115	CCSD
003-02286	0032286	0.115	CCSD
049-00223	0490223	0.115	SCSD
043-00001	0430001	0.113	North
060-06904	0606904	0.112	CCSD
050-00004B	0500004B	0.112	SCSD
046-00550	0460550	0.112	North
244-00030	2440030	0.112	North
258-00002	2580002	0.111	SSTN
047-00329	0470329	0.111	North
059-06220A	0596220A	0.111	CCSD
044-00307	0440307	0.110	North
170-00112	1700112	0.110	SSTN
044-00279	0440279	0.110	North
045-00207	0450207	0.110	North
043-05000	0435000	0.110	North
044-00292	0440292	0.110	North
044-00283	0440283	0.110	North
047-00029	0470029	0.110	North
371-00001	3710001	0.110	North
047-00323	0470323	0.110	North
272-00002	2720002	0.110	North
045-00078	0450078	0.110	North

Appendix C
Sub-basin R-values

<i>PRIMELP</i>	<i>Sub-basin ID</i>	<i>Existing Condition R-Value</i>	<i>Service Area</i>
044-00516	0440516	0.110	North
047-00017	0470017	0.110	North
047-00048	0470048	0.110	North
047-00022	0470022	0.109	North
045-00081	0450081	0.109	North
059-06614	0596614	0.109	CCSD
055-00092	0550092	0.109	North
044-00714	0440714	0.108	North
043-00017	0430017	0.108	North
055-00014	0550014	0.108	North
176-00018	1760018	0.108	North
176-00042	1760042	0.107	North
176-00052	1760052	0.107	North
046-00153	0460153	0.107	North
001-00328	0010328	0.106	CCSD
243-00012	2430012	0.106	North
044-00703	0440703	0.106	North
044-00220	0440220	0.106	North
275-00001	2750001	0.106	North
275-00043	2750043	0.106	North
243-00017	2430017	0.106	North
243-00004	2430004	0.106	North
044-00078	0440078	0.106	North
044-00213	0440213	0.106	North
001-00312	0010312	0.105	CCSD
044-00002	0440002	0.105	North
046-00110	0460110	0.105	North
151-00048	1510048	0.105	SCSD
046-00119	0460119	0.105	North
003-01929	0031929	0.105	CCSD
050-00385	0500385	0.105	SCSD
058-02851	0582851	0.105	SCSD
058-02833	0582833	0.105	SCSD
051-00403	0510403	0.105	SCSD
003-02005	0032005	0.105	CCSD
046-00435	0460435	0.105	North
051-00384	0510384	0.105	SCSD
050-00392	0500392	0.105	SCSD
045-00086	0450086	0.105	North
051-00419A	0510419A	0.105	SCSD
046-00006	0460006	0.105	North
046-00150	0460150	0.105	North
007-04625	0074625	0.104	CCSD
001-00205	0010205	0.104	CCSD
001-00293	0010293	0.104	CCSD
001-00425D	0010425D	0.103	CCSD
001-00207	0010207	0.103	CCSD
001-00425A	0010425A	0.103	CCSD
001-00155	0010155	0.103	CCSD



Appendix C
Sub-basin R-values

<i>PRIMELP</i>	<i>Sub-basin ID</i>	<i>Existing Condition R-Value</i>	<i>Service Area</i>
056-00208	0560208	0.102	SCSD
070-00003	0700003	0.102	SCSD
070-00001	0700001	0.102	SCSD
043-00299	0430299	0.101	North
046-00129	0460129	0.101	North
236-00002	2360002	0.101	SSTN
057-02007	0572007	0.100	SCSD
003-01783	0031783	0.100	CCSD
003-01871	0031871	0.100	CCSD
091-00004	0910004	0.100	SCSD
058-00130	0580130	0.100	SCSD
003-01787	0031787	0.100	CCSD
003-01888	0031888	0.100	CCSD
050-00616	0500616	0.100	SCSD
002-01405	0021405	0.100	CCSD
050-00642	0500642	0.100	SCSD
236-00091	2360091	0.100	SSTN

Appendix D
Private lateral Program Research Results

N.	Community	Legal Authority	FINANCIAL ASPECTS				Public Awareness Program	Number of Laterals	Comments
			Public Funds	Cost Sharing	Property Owner Loan Program	Property Owner Solely Responsible			
1	City of Cincinnati (MSD)	YES	YES Comment	YES	NO	NO	YES	NA	Developed the Stormwater Removal Program (SRP) to reimburse 100% up to \$3000 to remove stormwater connections, additional costs are the owner's responsibility.
2	Montgomery County, OH (MCSED)	YES	YES	YES	NO	NO	YES		MCSED reimburses 100% up to \$3000 to disconnect foundation drains, additional costs are the responsibility of the property owner.
3	City of Fairfield, OH	NO	NO	NO	NO	YES	YES	NA	Developed the Unauthorized Connections Program (UCP), this program is no longer in existence due to lack of council support. They do want to restart program soon.
4	City of Strongsville, OH	YES	YES	YES	YES	NO	YES		City is responsible for disconnecting unauthorized connections, owner is responsible for restoration. No formal program in place.
5	City of Union, OH	NO	NO	NO	NO	YES	YES		During recent rehabilitation work property owners were given the opportunity to replace their service connection through the private property for \$250.
6	City of West Lafayette, IN	YES	YES	NO	NO	NO	YES	NA	City developed a Disconnection Program to remove gravity foundation drains, 100% reimbursement is available if removal is complete within 1 year of notice of violation
7	Boston Water and Sewer Commission (BWSC)	YES	YES	YES	NO	NO	YES	135/yr	BWSC reimburse 100% up to \$3000 for breaks/blockage in service connections in the public right-of-way.
8	City of Bellaire, Texas	NO	NO	NO	YES	YES	NA		Payment program available. Payments and finance charges for repairs to the service connection must be made over five years.
9	City of Denver, Colorado	NO	NO	NO	YES	YES	YES		Payment program available. Payments and finance charges for repairs to the service connection are added to the monthly sewer bill.
10	City of Sacramento, CA	NA	NA	NA	NA	NA	NA		Details not available at this time.
11	Johnson County, KS	YES	YES	YES	NO	NO	NO		Details of cost sharing not available at this time, further investigation required.
12	City of Alameda, CA	NO	NO	NO	YES	YES	NO		As a last resort, property owners may make payments in a maximum of 5 annual installments for work performed by the City.

Appendix D
Private lateral Program Research Results

No.	Community	Legal Authority	FINANCIAL ASPECTS				Public Awareness Program	Number of Laterals	Comments
			Public Funds	Cost Sharing	Property Owner Loan Program	Property Owner Solely Responsible			
13	Tahoe City, CA	NO	NO	NO	NO	YES	NO		
14	City of Olivette, Missouri	YES	YES	YES	NO	NO	YES	since Jan. 05 22 Developed the Residential Sanitary Sewer Lateral Repair Program to reimburse 80% up to \$3500 to repair defective lateral sewer service lines.	
15	Castro Valley Sanitary District, CA (CVSD)	YES	YES Property Tax	YES	NO	NO	YES	28/yr Developed the Lateral Replacement Grant Program (LRGP) to reimburse 50% up to \$2000 to replace the sewer lateral	
16	West County Wastewater District, CA (WCWD)	YES	YES Leftover Fund	YES	NO	NO	YES	100/yr Developed the Building Sewer Replacement Grant Program (BSRP) to reimburse 50% up to \$2000 to replace qualified defective building sewers or sewer laterals.	
17	City of Mishawaka, IN	YES	YES Insurance	YES	NO	NO	YES	NA Offers insurance for a monthly fee of \$.50 with a \$250 deductible to cover sewer lateral repair and for all routine cleanings exceeding \$250.	
18	City of Creve Coeur, Missouri	YES	YES Property Tax	YES	NO	NO	YES	NA Developed the Sanitary Sewer Lateral Repair Program to reimburse 80% up to \$7500 to repair collapsed or broken residential sewer laterals	
19	City of Kirkwood, Missouri	YES	YES Property Tax	YES	NO	NO	YES	84/yr Developed Sewer Lateral Insurance with an annual fee of \$28 and \$740 deposit to reimburse 80% plus deposit to replace the sewer lateral.	
20	City of Windsor, Ontario	YES	YES	YES	NO	NO	YES	At this time the city offers grants up to \$1472 for a total sewer lateral replacement.	
21	City of Laguna Beach, CA	NO	NO	NO	NO	YES	YES	NA City requires testing of sewer laterals if roots are seen in the main sewer line and if during a house remodel plumbing fixtures are added.	
22	City of Burlingame, CA	NO	NO	NO	NO	YES	NO	NA City requires testing of sewer laterals whenever property changes hands	
23	City of Santa Barbara, CA	YES	YES	YES	NO	NO	NO	City will reimburse 50% up to \$2000 to replace sewer laterals.	
24	Mobile, AL Area Water and Sewer System (MAWSS)							As part of the Consent Decree as a SEP to spend at least \$20 million on private lateral repair/replacement-range \$1,000-2000/lateral	

**Appendix D
Private Lateral Program Research Results**

I.N.	Community	Legal Authority	FINANCIAL ASPECTS				Public Awareness Program	Number of Laterals	Comments
			Public Funds	Cost Sharing	Property Owner Loan Program	Property Owner Solely Responsible			
25	City of La Mesa, California	YES	YES	YES	NO	NO	YES		Developed the Backflow Prevention Program to assist property owners by paying 50% up to \$1350 for the installation of a backwater valve on the sewer lateral.
26	City of Hamilton, Ontario	YES	YES	YES	NO	NO	YES	250/yr	Developed the Sewer Lateral Repair Policy to reimburse 50% of the sewer lateral repair cost.
27	City of Albany, Oregon	YES	YES	NO	NO	NO	YES	50/yr	Replaces sewer laterals at no expense to homeowners. The city also pays up to \$750 of property restoration.
28	Vallejo Sanitation and Flood Control District (VSFCD)	YES	YES	YES	NO	NO	YES	400/yr	Developed Reimbursement Values for Owner Initiated Repair to sewer laterals. The owner is reimbursed a flat rate according to the length of pipe replaced.
29	City of St. Charles, Missouri	YES	YES	YES	NO	NO	YES	100/yr	The City will reimburse homeowners 80% up to \$5000 to replace sewer laterals.
30	City of San Luis Obispo, California	YES	YES	YES	NO	NO	NO	NA	Program no longer in service due to internal financial issues. Property owners are reimbursed 50% up to \$2000 to correct defects in their sewer lateral.
31	City of Florissant, Missouri	YES	YES Property Tax	YES	NO	NO	YES	150/yr	Developed Residential Sewer Lateral Insurance Program to cover 100% up to \$5000 to repair defective sewer laterals
32	City of Maplewood, Missouri	YES	YES Property Tax	NO	NO	NO	YES	40/yr	Repairs broken laterals with Public Works staff at no expense to the property owner.
33	Lynn, Massachusetts	NO	NO	NO	NO	YES	NO	NA	The City has a lateral inspection program in place to investigate reported backups. They provide no assistance to property owners who are solely responsible for repair sewer laterals.
34	City of Black Jack, Missouri	YES	YES Property Tax	YES	NO	NO	YES	?	Developed the Residential Sanitary Sewer Lateral Repair Program to pay 100% up to \$2000 to repair or replace defective sewer laterals.
35	City of Clayton, Missouri	YES	YES Property Tax	YES	NO	NO	YES	NA	The will reimburse homeowners 100% up to \$3000 to repair defective sewer laterals

Notes: NA-Information Not Available for the selected community.

*Several communities listed in Table have programs to remove unauthorized connections only; the programs do not include provisions for the connections for the correction of defective service connections.

**Several communities listed in Table require that the property owner receives bids from multiple plumbers/drainlayers before reimbursement.

Water Environment Federation

The Official Publication of WEFTEC

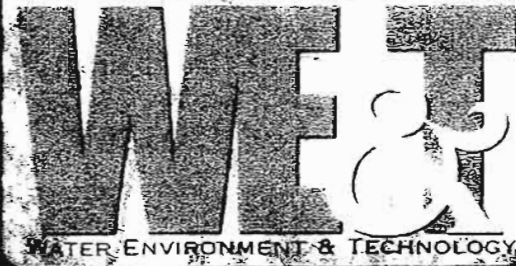

HOME REPAIR?

Although privately owned,
leaking laterals are a public problem

July 2005

OPERATIONS FORUM

A SPECIAL SECTION
FOR OPERATORS

Blending, pp. 13, 72

Security, p. 50

Asset management, pp. 10, 11



IT CAN BE DONE

Some legal issues to consider
when managing infiltration and
inflow from laterals

Michael H. Simpson

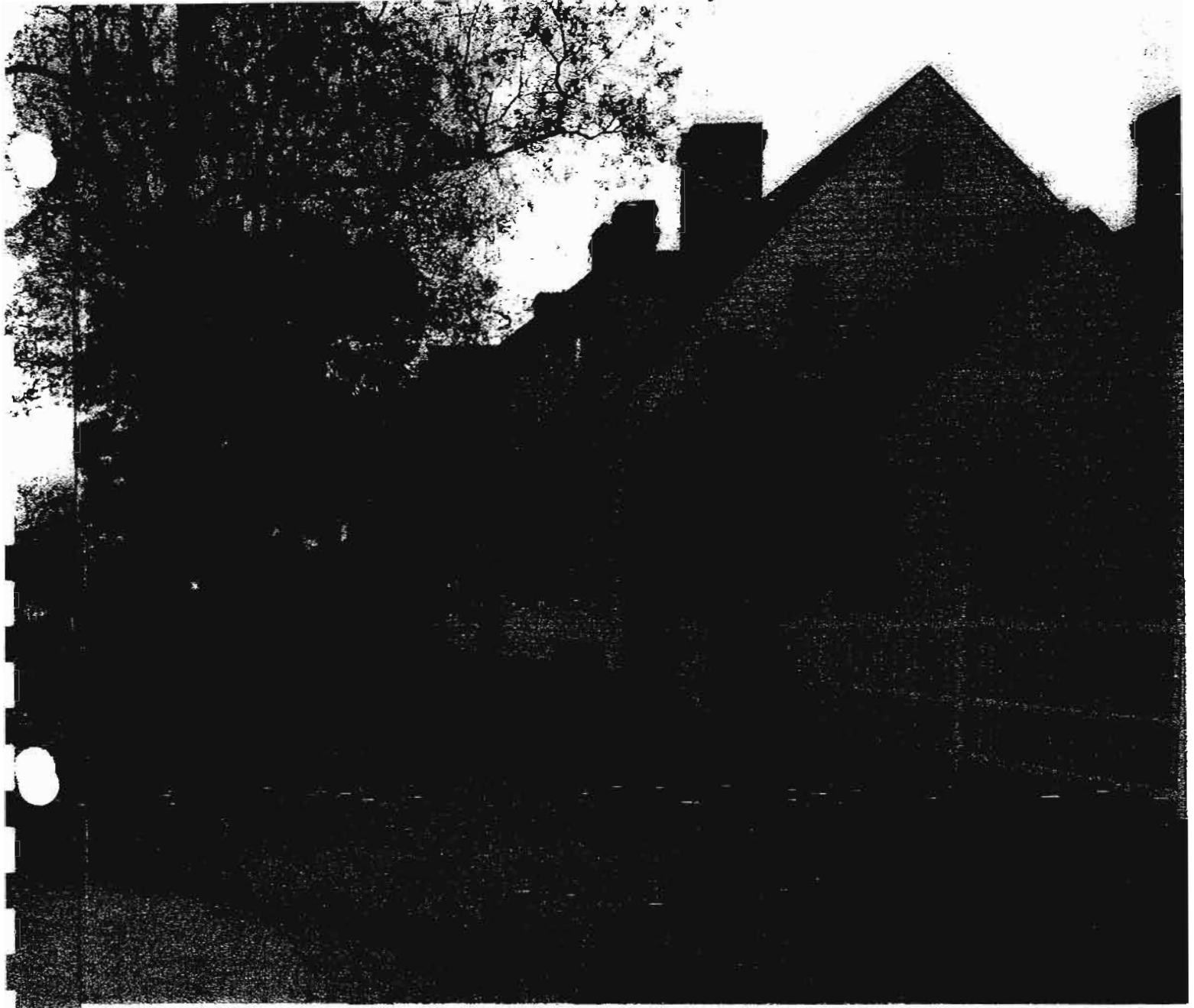

Infiltration and inflow (I/I) from laterals on private property is a significant source of sanitary sewer overflows (SSOs). A survey of 316 municipalities nationwide found that 69% had problems with I/I from private property and almost half believed that 5% to 50% of their I/I originated on private property, according to *Control of Infiltration and Inflow in Private Building Sewer Connections* (Water Environment Federation, 1999). Given this information, the U.S. Environmental Protection Agency stated, "the effectiveness of I/I removal efforts may be limited in many collection systems if private sources of I/I are not addressed." So many municipalities are attempting to identify the sources and extent of private-property I/I and create programs to minimize it.

To succeed, municipalities will need an excellent public education program and a well-writ-

ten ordinance. Teaching residents and elected officials about SSOs, private-property I/I, and the need for their help can be a daunting prospect for three reasons. First, many residents may have difficulty believing that their "small" property could significantly affect SSOs. Second, they may not believe that the problem exists on their specific property because it's underground, so they can't see it. Third, they may be reluctant to spend their money to fix an "invisible" problem that they don't believe will benefit them personally (by raising their property values, for example).

To protect themselves from lawsuits, municipalities should be well-versed in the related legal issues — particularly access, liability, and public financing — and create an ordinance for the private-property I/I control program. A well-crafted, comprehensive ordinance that specifies

the parameters, terms, and conditions of the private-property I/I control program can withstand challenges to municipal authority on this issue.

Access to Private Property

The leading case allowing municipalities to inspect private property for code compliance is *Camara v. Municipal Court* [387 U.S. 523(1967)]. In this case, a tenant refused to permit the local housing inspector to inspect his apartment for compliance with the housing code because the inspector did not have a search warrant. The property owner argued that the municipality violated the Fourth Amendment because the in-

pector lacked a search warrant, and that such a warrant would have to meet the same “probable cause” standard required for a criminal search warrant. The municipality argued that it did not need a warrant because the local ordinance authorized the inspector to enter private property to look for code violations.

According to the Fourth Amendment of the U.S. Constitution, “the right of people to be secure in their ... houses ... against unreasonable searches ... shall not be violated, and no warrants shall issue, but upon probable cause ... particularly describing the place to be searched, and the persons or things to be seized.”

Basically, this amendment protects the privacy and security of individuals against unreasonable or arbitrary invasions by government officials.

On hearing the case, the U.S. Supreme Court ruled that the municipality had to have a warrant to inspect private property for code violations. However, recognizing that routine, mandatory inspection of all structures is the only effective way to ensure universal code compliance, the court also ruled that the mere refusal of an owner or occupant to allow such inspections was sufficient “probable cause” for a municipality to obtain a warrant. In this way, the court tried to balance the public interest of inspecting for code violations and the private interest of protecting against unreasonable searches.

Shortly afterward, Wisconsin passed a law allowing a peace officer to obtain a private-property inspection warrant if the officer can show that he/she was refused entry for a code compli-

ance inspection. In 1999, the owners and tenants of a rental housing project sued Platteville, Wis., claiming that city inspectors had violated their Fourth Amendment rights (*Platteville Area Apartment Association v. City of Platteville* [179 F.3d 574 (7 Cir. 1999)]). City inspectors had been refused admittance to an apartment to inspect for compliance with specific provisions of the housing code, so they went to court, obtained a search warrant, and then searched the premises. The apartment association complained that the inspectors had searched for more than the warrant specifically allowed, thereby violating the owners’ and tenants’ rights.

The Federal Court of Appeals agreed. The court ruled that, under the Fourth Amendment, a search warrant must describe not only the place to be searched but also the persons and things to be seized as a result of the search. The court said an inspector could only search for the items specified in the search warrant plus any potential violations that might be in “plain view” during inspection. A search for a given type of evidence implies a limitation on the parts of the premises that may be searched, the court said, noting that “if you are looking for an elephant, searching for it in a chest of drawers is not reasonable.”

Unlike Wisconsin, Kansas does not have an inspection statute. However, Johnson County, Kan., had adopted an ordinance designed to remove private-property I/I from the local sanitary sewer system. The ordinance included an inspection provision, and the county adopted inspection procedures detailing requirements from initially contacting the homeowner to completing the corrective work. When a number of residents sued the county, claiming that the inspections violated their right to privacy under the Fourth Amendment, the Kansas Supreme Court evaluated the local ordinance and procedures and concluded that they did not violate the Fourth Amendment (*Board of Co. Comm. of Johnson County, Kansas v Grant, et al.* [264 Kan. 58, 954 p. 2d 695 (1998)]). In its decision, the court noted that

- the ordinance was reasonable and balanced public and private interests;
- it demonstrated that the municipality had a legitimate interest in preventing sewer backups;
- it did not discriminate (all properties had to be inspected);
- it was designed to eliminate as many prohibited connections and discharges as possible;
- the private-property I/I inspection procedures were detailed and seemed reasonable; and

The court said an inspector could only search for the items specified in the search warrant plus any potential violations that might be in “plain view” during inspection. A search for a given type of evidence implies a limitation on the parts of the premises that may be searched, the court said, noting that “if you are looking for an elephant, searching for it in a chest of drawers is not reasonable.”

- the inspections were limited to finding violations of the ordinance involving basement plumbing facilities and exterior stormwater drainage facilities.

So, given these rulings, local inspectors should be able to obtain search warrants to inspect private property for improper I/I as long as

- they have inspection authority under a well-written state law or local ordinance,
- the property owner or occupant refused access,
- the warrant specifies why the inspection is needed and where it will occur, and
- the inspection is limited to what the warrant authorizes, plus whatever else happens to be in “plain view.”

Potential Liability

This article only discusses a municipality's potential liability for damages caused by negligent acts or omissions.

In Wisconsin, a municipality is not liable for negligent acts that occur while the municipality is performing a *discretionary* act (also called quasi-judicial or quasi-legislative functions). However, the municipality is liable for any damages caused by the negligent performance of *ministerial* acts.

What's the difference between discretionary and ministerial acts? According to the Wisconsin Supreme Court, a public officer's duty is ministerial “only when [the act or duty] is absolute, certain, and imperative, involving merely the performance of a specific task when the law imposes, prescribes, and defines the time, mode, and occasion for its performance with such certainty that nothing remains for judgment or discretion” (*Lister v. Board of Regions* [72 Wis. 2d 282, 301 (1976)]).

Wisconsin courts struggled to determine which acts are discretionary and which are ministerial until 2000, when a dissent in a Wisconsin Supreme Court case finally faced reality in stating:

The difference between “discretionary” and “ministerial” is artificial. An act is said to be discretionary when an officer must exercise some judgment in determining whether and how to perform an act. The problem is that it would be difficult to conceive of an official act, no matter how directly ministerial, that did not admit of some discretion in the manner of its performance, even if it involved only the driving of the nail (*Willow Creek Ranch LLC v. Town of Shelby* [2000 WI 56, 235 Wis. 2d 409, 471 (2000)]).

Nevertheless, Wisconsin courts have applied this standard to liability cases involving sanitary sewers. The following principles can be extracted from these cases:

- **Sewer system plans and designs are discretionary acts.** While a truck was lawfully discharging effluent into a manhole in a public road, a motorist swerved into the incoming lane to avoid it and collided with another car. After settling the injury claims, the motorist's insurance company sued the local sewerage commission for negligent sewer system design (*Allstate Ins. Co. v. Metropolitan Sewerage Commission* [80 Wis. 2d, 10 (1977)]). The insurance company claimed that the

“The difference between ‘discretionary’ and ‘ministerial’ is artificial. An act is said to be discretionary when an officer must exercise some judgment in determining whether and how to perform an act. The problem is that it would be difficult to conceive of an official act, no matter how directly ministerial, that did not admit of some discretion in the manner of its performance, even if it involved only the driving of the nail.”

manhole should have been installed off the road, not in it, and this negligence caused the accident. The Wisconsin Supreme Court concluded that “where, when, and how to build sewer systems are legislative determinations. ... It is not for the court to judge or a jury to ‘second guess’ [sewerage agencies] in these determinations, nor to find they are liable for negligence.”

- **Sewer system operation and maintenance are ministerial acts.** In *Mennick v. City of Menasha* [200 Wis. 2d 737 (Ct. App. 1996)], the court determined that once a municipality decides to install a sanitary sewer, it has a duty to operate and maintain the system properly. Such work is ministerial, the court said, so a municipality is not entitled to immunity from damages if it negligently operated or maintained its sewer system.

Wisconsin law also makes municipalities liable if a negligent code-compliance inspection results in damages — unless the inspection was conducted by an independent contractor. In *Griffin v. Poetzel* [2001 WI App. 207, 247 Wis. 2d 906 (Ct. App. 2001)], the Wisconsin Court of Appeals ruled that a municipality could hire an independent contractor to perform code-compliance inspections, and if the contractor was truly independent and performed negligently, the municipality was not liable for related damages.

However, contractors hired by a Wisconsin municipality are entitled to the same immunity as the municipality if the municipality wrote reasonably precise specifications for the contractor's work, the contractor complied with those specifications, and the contractor warned the government of any problems with the specifications that were known to the contractor but not necessarily known to the government (*Lyons v. CNA Insurance* [207 Wis. 2d 446 (App. 1996)]).

So, a municipality may want to carefully structure its private-property I/I control program to minimize potential liability. For example, a Wisconsin municipality might hire independent contractors to perform the inspections and investigations and

- require contractors to carry insurance to cover potential related claims,
- make sure that the contracts protect the municipality from damages caused by contractors,
- obtain insurance to cover potential damages in case a court rules that the inspectors did not qualify as independent contractors, and
- make sure that property owners agree to waive claims against the municipality and instead pursue the contractor for compensation due to negligence-related damages.

Wisconsin municipalities might also hire independent contractors to perform any corrective work and subsequent maintenance needed, using the same protections described above. Alternatively, they might make property owners responsible for corrective work and subsequent maintenance. If so, a municipality could help the property owners by

- “pre-qualifying” contractors (including preparing form contracts and negotiating “volume-discount” prices) so property owners could quickly and efficiently contract for corrective work, and
- establishing performance standards for various types of corrective work, which would reduce negotiations between the contractor and property owner and help protect the property owner from being sold a “Cadillac” when a “Chevrolet” would suffice.

Laws in other states may differ from those in Wisconsin, so municipalities should begin by carefully evaluating the extent to which their state's laws could make them liable for various aspects of a private-property I/I control program. They then could create a program that minimizes their risks while preventing private-property I/I from entering sanitary sewers.

Using Public Money to Finance Projects on Private Property

Like many states, Wisconsin has a *public purpose doctrine* that requires public money to only be spent for a public purpose. Although the state constitution lacks a specific clause articulating this doctrine, the Wisconsin Supreme Court has recognized it as a well-established constitutional principle. According to the court, the “concept of public purpose is a fluid one and varies from time to time ... as the government and its people change. Essentially, public purpose depends on what the people expect and want their government to do for the society as a whole” (*State ex rel. Warren v. Reuter* [44 Wis. 2d 201, 213 (1969)]).

Consider, for example, a case in which the Wisconsin Legislature wanted to give money to Marquette School of Medicine, a private institution, to avoid a doctor shortage in the state (*State ex rel. Warren v. Reuter* [44 Wis. 2d 201 (1969)]). The plaintiffs believed that giving money to the school would solely benefit the institution, and therefore violate the public purpose doctrine. In its decision, the Wisconsin Supreme Court ruled that the challengers had confused the means with the end. The court held that:

An act is constitutional if it is designed in its principal parts to promote a public purpose so the attainment of the public purpose is a reasonable probability. ... The appropriation is not primarily to benefit the Marquette School of Medicine but to promote and maintain public health. The law is no frivolous pretext for giving money to a private school but using of a private school to attain a public purpose. What benefit is derived by the medical school is necessary and incidental to the main purpose (*Id.* at 214).

Consequently, if the public expenditure is intended for the public good, it will conform with the public purpose doctrine even if it also incidentally benefits a private party.

The Wisconsin Supreme Court has also found that public health — specifically, providing sanitary sewer services — falls within the scope of the public purpose doctrine. In the Marquette School of Medicine case, the Wisconsin Supreme Court stated that “it cannot be seriously questioned that the health of the people of this state is of great concern and the proper object of our state government's interest.” And in *Brookfield v. Milwaukee Metropolitan Sewerage District* [171 Wis. 2d 400, 435-436 (1992)], the court held that

"it is beyond question that sewerage services promote the public health and well being."

It is very likely that a court would find that a private-property I/I control program promotes public health by protecting the state's water supply, reducing SSOs, reducing basement backups, and other benefits. While to date no case directly addresses this point, the Wisconsin Supreme Court's reasoning in other cases suggests that the benefits homeowners would receive by having their laterals fixed would be incidental to the overall goal of protecting the state's public health, allowing public money to be spent for this purpose.

These cases also illustrate the type of record that a government entity should consider creating to support the public purpose of any proposed expenditure of public money on private property. For example, the municipality should consider creating a record that contains evidence that the municipality's goal in funding a private-property I/I control program is to preserve public health by protecting the state's water supply, reducing SSOs, and other pertinent reasons. A record containing this evidence would help overcome challenges to a program that used public funding to finance a private-property I/I control program.

Components of a Model Ordinance

One of the best ways to optimize the possibility of success is by adopting a comprehensive ordinance that addresses these and other pertinent legal issues. It should cover at least the following major topics.

Rationale/justification for the program. Explain the need and overall justification for the ordinance.

Legislative authority and severability. Set forth the state constitutional and statutory authority for the ordinance. Note that if any section of the ordinance is found to be unconstitutional, only that section would fail; the rest of the ordinance would remain in effect.

Scope and application of the ordinance. Identify the properties subject to the ordinance; show that it is designed to be a comprehensive program. This section also would include any exceptions that property owners could cite to excuse their compliance with the ordinance. For example, an exception could be made if potential damages may occur as a result of required corrective work. An exception also might be granted if compliance costs exceeded a certain dollar amount or an expected benefit.

Prohibited acts and connections. Define what

types and degrees of I/I are prohibited. To date, many ordinances have addressed improper inflows to the sanitary sewer, but failed to address infiltration.

Responsibility for compliance. Identify which parties are responsible for complying with the various tasks involved in a private-property I/I control program.

Rights of the municipality. Spell out the municipality's rights, including (but not limited to)

- access and inspection rights;
- the right to identify and specify design and performance standards for the program;
- the right to issue orders to inspect, correct, and maintain the system;
- the right to perform work if a property owner fails to execute his/her responsibilities; and
- specific enforcement powers, rights, and procedures.

Available financial assistance and procedures for obtaining financing. Identify what type of financial assistance, if

any, will be provided to property owners for undertaking their responsibilities under the ordinance. Also, specify the procedures that a property owner would have to follow to obtain such financial assistance, and set forth the terms of that financing.

Appeal rights. Set forth a property owner's rights to appeal decisions made by the local authority and the procedures that must be followed in filing and prosecuting such appeals.

Know Your State's Laws

These are just some of the legal issues that a municipality should consider when designing and implementing a private-property I/I control program. Statutory and case law in each state will no doubt provide guidance on developing a program, and these guidelines need to be carefully evaluated to make sure that the program is developed to maximize its chances to withstand legal challenges and minimize a municipality's liability.

Michael H. Simpson is a shareholder and chairs the Environmental Law practice group at Reinhart Boerner Van Dewren s.c. (Milwaukee).

It is very likely that a court would find that a private-property I/I control program promotes public health by protecting the state's water supply, reducing SSOs, reducing basement backups, and other benefits.



Preliminary Opinion of Probable Cost
New SWWTP Headworks/Influent Pump Station Option
7/27/2005 9:14

New Peak Wet Weather Headworks			
Description	Number of Units	Cost Per Unit	Total Cost
19 Million Gallon Flow Equalization Basin			\$8,521,776
Combined 200 MGD Pump Station			\$1,660,000
Grit Removal Facilities			\$2,140,000
Screening Facilities			\$2,900,000
Odor Control			\$700,000
Site Work			\$348,000
Subtotal			\$16,269,776
Electrical and Instrumentation (17%)			\$2,765,862
Subtotal			\$19,035,638
Insurance, Labor (15%)			\$2,855,346
Subtotal			\$21,890,984
Mobilization and Bonds (5%)			\$1,094,549
Overhead and Profit (15%)			\$3,283,648
Subtotal			\$26,269,180
Contingency (15%)			\$3,940,377
TOTAL			\$30,209,557



Preliminary Opinion of Probable Cost
SWWTP Upgrade

7/27/2005 9:14

SWWTP Upgrade			
Description	Number of Units	Cost Per Unit	Total Cost
New Influent Splitter Box			\$323,500
Trickling Filter 5 Through 8 Demoliton			\$450,000
Aeration Basin			\$8,687,724
New 160 Foot Diamter Final Clarifiers			\$3,039,172
Existing Clarifier Rehab			\$3,000,000
RAS/WAS Pump Stations			\$700,000
Final Effluent Pump Station (100 MGD) (Renovate Existing)			\$687,500
UV Disinfection System			\$3,450,000
Major Yard Piping			\$400,000
Subtotal			\$20,414,396
Electrical and Instrumentation (17%)			\$3,470,447
Subtotal			\$23,884,843
Insurance, Labor (15%)			\$3,582,726
Subtotal			\$27,467,570
Mobilization and Bonds (5%)			\$1,373,378
Overhead and Profit (15%)			\$4,120,135
Subtotal			\$32,961,084
Contingency (15%)			\$4,944,163
TOTAL			\$37,905,246

City of Baton Rouge
 O&M Costs of Current and Proposed Programs
 WWTP costs include electricity, gas, chemicals
 Pump costs include power only
 Sewer costs include cleaning only

infiltration rate = \$ 1,000 gallons/acre/day \$ 4,424
 infiltration rate = 3,000 gal/ft/yr
 infiltration reduction = 80%
 gravity sewer length = 1,600 miles

		Baton Rouge Annual Budgets						
		Infiltration Reduction		Total WWTPs	Pumps	Gravity SSO/Stoppage Response	Gravity Contract Cleaning	
Flow, mgd	LF of	1000 gallons/yr	mgd	54.0	54.0			
\$/1000 gal	Rehab	Cumulative LF		\$	\$	\$	\$	
Current			80%	0.187	0.058	0.473	0.237	
				\$ 3,690,000	\$ 1,150,000	\$ 2,000,000	\$ 2,000,000	
2005	50,000	50,000	120,000	0.3	\$ 3,667,534	\$ 1,142,998	\$ 1,976,326	
2006	220,000	270,000	648,000	1.8	\$ 3,568,685	\$ 1,112,192	\$ 1,872,159	
2007	220,000	490,000	1,176,000	3.2	\$ 3,469,836	\$ 1,081,385	\$ 1,767,992	
2008	220,000	710,000	1,704,000	4.7	\$ 3,370,986	\$ 1,050,578	\$ 1,663,826	
2009	220,000	930,000	2,232,000	6.1	\$ 3,272,137	\$ 1,019,772	\$ 1,559,659	
2010	220,000	1,150,000	2,760,000	7.6	\$ 3,173,288	\$ 988,965	\$ 1,455,492	
2011	220,000	1,370,000	3,288,000	9.0	\$ 3,074,438	\$ 958,158	\$ 1,351,326	
2012	200,000	1,570,000	3,768,000	10.3	\$ 2,984,575	\$ 930,152	\$ 1,256,629	
2013	200,000	1,770,000	4,248,000	11.6	\$ 2,894,712	\$ 902,146	\$ 1,161,932	
2014	200,000	1,970,000	4,728,000	13.0	\$ 2,804,849	\$ 874,140	\$ 1,067,235	
ANNUAL SAVINGS =				\$ 885,151	\$ 275,860	\$ 932,765	\$ 466,383	
ANNUAL ASSOCIATED WITH GWI REDUCTION =							\$ 2,560,158	
ANNUAL CHEMICAL SAVINGS =							\$ 400,000	
ANNUAL SAVINGS ASSOCIATED WITH PLANT O&M =							\$ 301,334	
TOTAL ANNUAL O&M SAVINGS =							\$ 3,261,492	

**Appendix F
South WWTP O&M Costs**

	<i>Annual Hours of operation</i>	<i>Annual Flow</i>	<i>flow gpm</i>	<i>ft</i>	<i>hp</i>	<i>motor</i>	<i>Annual power \$</i>
influent pump station	12,014	16	11,111	40	112	229	102,701
primary effluent pump station	24,027	32	22,222	40	225	459	410,806
scrubber/blowers	7					25	7
Wet weather pump station	346	88	61,111	40	618	1,261	16,249
Odor control/1 unit	21,024	N/A	N/A	10	10	20	15,998
Total electrical savings							545,761
<i>Non-electric costs</i>							
RMP training and procedures	\$	1,800	annually				
Chemical delivery	\$	2,200	annual				
R/R at existing HW	\$	83,000	annual R/R based on percent of replacement cost for screens, conveyer, grit removal				
R/R PEPS1	\$	80,000	Assumes 8 pumps at 250k each				
R/R influent pumps	\$	32,000	Assumes 4 pumps at \$200k each				
Rags, grit damage at sluge pumps	\$	16,000	Assumes 8 pumps at 50k each				
Snail management/maintenance	\$	104,000	labor of 2 employees full time lost wages				
Clarifier cleaning (1 per year)	\$	100,000	due to rags/grit (assumes \$100k each)				
Digester cleaning - snails	\$	300,000	Assumes one digester per year cleaned				
blowers for trickling filters		35,040				20	26,129
Annual cost of new UV							(300,000)
Annual cost of blowers		8,760				200	(500,000)
Annual cost of new influent pumps		9,855	36	25,000	40	253	516
Non-electric total costs							719,000
Total savings							301,334

Appendix B



Department of Public Works

City of Baton Rouge
Parish of East Baton Rouge

Post Office Box 1471
Baton Rouge, Louisiana
70821

DC
COPY

May 25, 2005

Department of Environmental Quality
Office of Water Resources
ATTN: Permits
Post Office Box 82215
Baton Rouge, Louisiana 70884-2215

Re: Municipal Water Pollution Prevention (MWPP) Environmental Audit Report

NPDES PERMIT NUMBER:
LA0036439 AI# 4843

Dear Sirs:

As required by your office, we are submitting the annual Municipal Water Pollution Prevention Environmental Audit report along with the MWPP Resolution. This report represents our North Wastewater Treatment Plant.

If you have any questions concerning this matter, please contact Mr. Charles O'Brien of my staff at (225) 389-3240.

Sincerely yours,

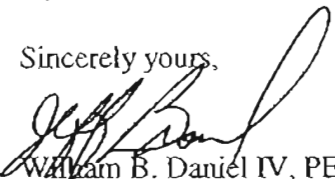
For 
William B. Daniel IV, PE
Interim Director of Public Works

WBD/MO/pas

xc: Jeff Broussard, Deputy Director of Public Works
Richard Wright, PE IV, - DPW- SOGA
Robert Groht, Jr., Wastewater Treatment Plant Manager
Bob Wilks, Wastewater Treatment Process Control Supervisor
Walter Jenkins, Assistant WW Treatment Plant Manager
Garcia Dialekwa, Wastewater Laboratory Supervisor
Cheryl Berry, PE II - DPW - SOGA

Attachment(s):

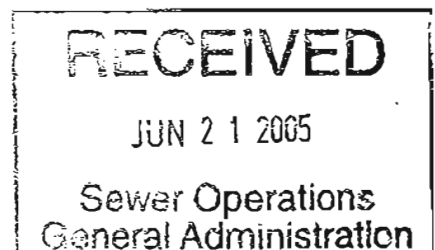

LOUISIANA

MUNICIPAL WATER POLLUTION PREVENTION

MWPP



Facility Name:

NORTH TREATMENT PLANT

LWDPS Permit Number:

NPDES Permit Number:

LA0036439

AI# 4843

Address:

55 MILLS AVENUE

BATON ROUGE

LOUISIANA

Parish:

EAST BATON ROUGE

(Person Completing Form) Name:

CHARLES M. O'BRIEN

Title:

ASSISTANT WW LAB SUPERVISOR

Date Completed:

MAY 25, 2005

Instructions to the Operator-in-Charge

- 1. Complete only the sections of the Environmental Audit which apply to your wastewater treatment system. Leave sections that do not apply blank and enter a "0" for the point value.**
- 2. Parts 1 through 7 contain questions for which points may be generated. These points are intended to communicate to the department and the governing body or owner what actions will be necessary to prevent effluent violations. Place the point totals from parts 1 through 7 on the Point Calculation page.**
- 3. Add up the point totals.**
- 4. Submit the Environmental Audit to the governing body or owner for their review and approval.**
- 5. The governing body must pass a resolution which contains the following items:**
 - a. The resolution or letter must acknowledge the governing body or owner has reviewed the Environmental Audit.**
 - b. The resolution must indicate specific actions, if any, will be taken to maintain compliance and prevent effluent violations. Proposed actions should address the parts where maximum or close to maximum points were generated in the Environmental Audit.**
 - c. The resolution should provide any other information the governing body deems appropriate.**

PART 1: INFLUENT FLOW/LOADINGS

Part 1: Influent Flow/Loadings (All plants)

A. List the average monthly volumetric flows and BOD loadings received at your facility during the last reporting year.

Col. 1 Average Monthly Flow (million gallons per day, MGD)		Col. 2 Average Monthly BOD ₅ Concentration (mg/l)		Col. 3 Average Monthly BOD ₅ Loading (pounds per day)
21.24	X	138	X 8.34 =	24,446
35.34	X	98	X 8.34 =	28,884
35.51	X	89	X 8.34 =	26,358
26.04	X	101	X 8.34 =	21,934
21.23	X	120	X 8.34 =	21,247
21.27	X	116	X 8.34 =	20,577
28.26	X	109	X 8.34 =	25,690
29.87	X	102	X 8.34 =	25,410
26.24	X	109	X 8.34 =	23,854
30.15	X	107	X 8.34 =	26,905
34.56	X	86	X 8.34 =	24,788
23.96	X	117	X 8.34 =	23,380

BOD loading = Average Monthly Flow (in MGD) x Average Monthly BOD concentration (in mg/l) x 8.34.

B. List the design flow and design BOD loading for your facility in the blanks below. If you are not aware of these design quantities, refer to your Operation and Maintenance Manual (O & M) or contact your consulting engineer.

Design Flow, MGD	54	X 0.90 =	48.60
Design BOD, lb/day	75,210	X 0.90 =	67,689

C. How many months did the monthly flow (Col. 1) to the wastewater treatment plant (WWTP) exceed 90% of design flow?

Circle the number of months and corresponding point total. Write the point total in the box below at the right.

months	<input checked="" type="radio"/> 0	1	2	3	4	5	6	7	8	9	10	11	12	months
points	<input checked="" type="radio"/> 0	0	0	0	0	5	5	5	5	5	5	5	5	points

Write 0 or 5 in the C point total box C Point Total

D. How many months did the monthly flow (Col. 1) to the WWTP exceed the design flow?
Circle the number of months and corresponding point total. Write the point total in the box below at the right.

months	<input checked="" type="radio"/> 0	1	2	3	4	5	6	7	8	9	10	11	12	months
points	<input checked="" type="radio"/> 0	5	5	10	10	15	15	15	15	15	15	15	15	points

Write 0, 5, 10, or 15 in the D point total box D Point Total

E. How many months did the monthly BOD loading (Col. 3) to the WWTP exceed 90% of the design loading?
Circle the number of months and corresponding point total. Write the point total in the box below at the right.

months	<input checked="" type="radio"/> 0	1	2	3	4	5	6	7	8	9	10	11	12	months
points	<input checked="" type="radio"/> 0	0	5	5	5	10	10	10	10	10	10	10	10	points

Write 0, 5, or 10 in the E point total box E Point Total

F. How many times did the monthly BOD loading (Col. 3) to the WWTP exceed the design loading?
Circle the number of months and corresponding point total. Write the point total in the box below at the right.

months	<input checked="" type="radio"/> 0	1	2	3	4	5	6	7	8	9	10	11	12	months
points	<input checked="" type="radio"/> 0	10	20	30	40	50	50	50	50	50	50	50	50	points

Write 0, 10, 20, 30, 40, or 50 in the F point total box F Point Total

G. Add together each point total for C through F and place this sum in the box below at the right.

TOTAL POINT VALUE FOR PART 1 (max=80)

Also enter this value on the point calculation table on page 16.

Facility Name

LA0036439 NORTH PLANT

PART 2: EFFLUENT QUALITY/PLANT PERFORMANCE

A. List the monthly average effluent BOD and TSS concentrations produced by your facility during the last reporting year.

Month	Column 1 Avg. Monthly BOD (mg/l)	Column 2 Avg. Monthly TSS (mg/l)
APRIL	32	32
MAY	19	22
JUNE	22	21
JULY	19	18
AUGUST	20	18
SEPTEMBER	20	17
OCTOBER	19	22
NOVEMBER	21	23
DECEMBER	25	20
JANUARY	29	28
FEBRUARY	26	29
MARCH	32	29

B. List the monthly average permit limits for your facility in the blanks below.

	Permit Limit		90% of Permit Limit
BOD, mg/l	30	X 0.90 =	27
TSS, mg/l	30	X 0.90 =	27

C. Continuous Discharge to Surface Water

i. How many months did the effluent BOD concentration (Col. 1) exceed 90% of permit limits? Circle the number of months and corresponding point total. Write the point total in the box below at the right.

months	0	1	2	3	4	5	6	7	8	9	10	11	12	months
points	0	0	10	20	30	40	40	40	40	40	40	40	40	points

Write 0, 10, 20, 30 or 40 in the i point total box 20 i Point Total

ii. How many months did the effluent BOD concentration (Col. 1) exceed permit limits? Circle the number of months and corresponding point total. Write the point total in the box below at the right.

months	0	1	2	3	4	5	6	7	8	9	10	11	12	months
points	0	5	5	10	10	10	10	10	10	10	10	10	10	points

Write 0, 5, or 10 in the ii point total box 5 ii Point Total

iii. How many months did the effluent TSS concentration (Col. 2) exceed 90% of permit limits? Circle the number of months and corresponding point total. Write the point total in the box below at the right.

months	0	1	2	3	4	5	6	7	8	9	10	11	12	months
points	0	0	10	20	30	40	40	40	40	40	40	40	40	points

Write 0, 10, 20, 30, or 40 in the iii point total box 30 iii Point Total

iv. How many months did the effluent TSS concentration (Col.2) exceed permit limits? Circle the number of months and corresponding point total. Write the point total in the box below at the right.

months	0	1	2	3	4	5	6	7	8	9	10	11	12	months
points	0	5	5	10	10	10	10	10	10	10	10	10	10	points

Write 0, 5, or 10 in the iv point total box 5 iv Point Total

v. Add together each point total for i through iv and place this sum in the box below at the right.

TOTAL POINT VALUE FOR PART 2 60 (max=100)
Also enter this value on the point calculation table on page 16.

Facility Name

LA0036439 NORTH PLANT

D. Other Monitoring and Limits

i. At any time in the past year was there an exceedance of a permit limit for other pollutants such as: ammonia-nitrogen, phosphorus, pH, residual chlorine, or fecal coliform?

✓ Check one box Yes No If yes, please describe:

One (1) 7-day geometric mean exceedance during the monitoring period. (Fecal Coliform)

ii. At any time in the past year was there a "failure" of a Biomonitoring (Whole Effluent Toxicity) test of the effluent?

✓ Check one box Yes No If yes, please describe:

iii. At any time in the past year was there an exceedance of a permit limit for a toxic substance?

✓ Check one box Yes No If yes, please describe:

PART 3: AGE OF THE WASTEWATER TREATMENT FACILITIES

A. What year was the wastewater treatment plant constructed or last major expansion/improvements completed? 1998

Current Year - (Answer to A) = Age in years

2005 - 1998 = 7 years

Enter Age in Part C below.

B. Check the type of treatment facility that is employed:

		Factor
<u>X</u>	Mechanical Treatment Plant (Trickling filter, activated sludge, etc.) Specify Type <u>Trickling Filter</u>	<u>2.5</u>
_____	Aerated Lagoon	2.0
_____	Stabilization Pond	1.5
_____	Other (Specify) _____	1.0

C. Multiply the factor listed next to the type of facility your community employs by the age of your facility to determine the total point value of Part 3:

$$\text{TOTAL POINT VALUE FOR PART 3} = \frac{2.5}{\text{FACTOR}} \times \frac{7}{\text{AGE}} = \boxed{17.5} \quad (\text{max} = 50)$$

Also enter this value or 50, which ever is less, on the point calculation table on page 16.

D. Please attach a schematic of the treatment plant.

PART 4: OVERFLOWS AND BYPASSES

A. (1) List the number of times in the last year there was an overflow, bypass, or unpermitted discharge of untreated or incompletely treated wastewater due to heavy rain: 0
 (Circle One) 0 = 0 points 1 = 5 points 2 = 10 points
 3 = 15 points 4 = 30 points 5 or more = 50 points

(2) List the number of bypasses, overflows, or unpermitted discharges shown in A (1) that were within the collection system and the number at the treatment plant.

Collection System 0 Treatment Plant 0

B. (1) List the number of times in the last year there was a bypass or overflow of untreated or incompletely treated wastewater due to equipment failure, either at the treatment plant or due to pumping problems in the collection system: 61
 (Circle One) 0 = 0 points 1 = 5 points 2 = 10 points
 3 = 15 points 4 = 30 points 5 or more = 50 points

(2) List the number of bypasses or overflows shown in B (1) that were within the collection system and the number at the treatment plant.

Collection System 61 Treatment Plant 0

C. Specify whether the bypasses came from the city or village sewer system or from contract or tributary communities/sanitary districts, etc.

D. Add the point values circled for A and B and place the total in the box below.

TOTAL POINT VALUE FOR PART 4 50 (max=100)

Also enter this value on the point calculation table on page 16.

E. List the person responsible for reporting overflows, bypasses, or unpermitted discharges to State and Federal authorities:

CHARLES M. O'BRIEN, ASSISTANT WASTEWATER LABORATORY SUPERVISOR
 (225) 389-3240

Describe the procedure for gathering, compiling, and reporting:

THE PROCEDURE FOR GATHERING, COMPILING AND REPORTING IS SPECIFIED IN THE PERMIT.

Facility Name

LA0036439

NORTH PLANT

PART 5: SLUDGE STORAGE AND DISPOSAL SITES

A. Sludge Storage

How many months of sludge storage capacity does your wastewater treatment facility have available, either on-site or off-site?

Circle the number of months and corresponding point total. Write the point total in the box below at the right.

months	<2	2	3	4 to 5	>6	months
points	50	30	20	10	0	points

Write 0, 10, 20, 30, or 50 in the A point total box A Point Total

B. For how many months does your facility have access to (and approval for) sufficient land disposal sites to provide proper land disposal?

Circle the number of months and corresponding point total. Write the point total in the box below at the right.

months	<2	6 to 11	12 to 23	24 to 35	>36	months
points	50	30	20	10	0	points

Write 0, 10, 20, 30, or 50 in the B point total box B Point Total

C. Add together the A and B point values and place this sum in the box below at the right:

TOTAL POINT VALUE FOR PART 5 (max=100)

Also enter this value on the point calculation table on page 16.

PART 6: NEW DEVELOPMENT

A. Please provide the following information for the total of all sewer line extensions which were installed during the last year.

Design Population: 100

Design Flow: 0.04 MGD

Design BOD₅: 48 mg/l

B. Has an industry (or other development) moved into the community or expanded production in the past year, such that either flow or pollutant loadings to the sewerage system were significantly increased (5% or greater)?

(Circle One)

No = 0 points

Yes = 15 points

Describe: _____

List any new pollutants: _____

C. Is there any development (industrial, commercial, or residential) anticipated in the next 2-3 years, such that either flow or pollutant loadings to the sewerage system could significantly increase?

(Circle One)

No = 0 points

Yes = 15 points

Describe: _____

List any new pollutants that you anticipate: _____

D. Add together the point value circled in B and C and place the sum in the blank below.

TOTAL POINT VALUE FOR PART 6

0

(max=30)

Also enter this value on the point calculation table on page 16.

Facility Name

LA0036439 NORTH PLANT

PART 7: OPERATOR CERTIFICATION AND EDUCATION

- A. What was the name of the operator-in-charge for the reporting year? GERALD SPRULL Name
- B. What is his/her certification number? 10-560 Cert. #
- C. What level of certification is the operator-in-charge required to have to operate the wastewater treatment plant? WASTEWATER TRMT. IV Level Required
- D. What is the level of certification of the operator-in-charge? WASTEWATER TRMT. IV Level Certified
- E. Was the operator-in-charge of the report year certified at least at the grade level required in order to operate this plant? ✓ Check one box yes = 0 points no = 50 points
Write 0 or 50 in the E point total box E Point Total
- F. Has the operator-in-charge maintained recertification requirements during the reporting year? ✓ Check one box yes no
- G. How many hours of continuing education has the operator-in-charge completed over the last two calendar years? ✓ Check one box 12 hours or more = 0 points Less than 12 hours = 50 points
Write 0 or 50 in the G point total box G Point Total
- H. Is there a written policy regarding continuing education and training for wastewater treatment plant employees? ✓ Check one box yes no

Explain:

16 HOURS OF TRAINING IN WASTEWATER TREATMENT EVERY TWO YEARS.

- I. What percentage of the continuing education expenses of the operator-in-charge were paid for:
By the permittee? 100%
By the operator? 0
- J. Add together the E and G point values and place this sum in the box below at the right:

TOTAL POINT VALUE FOR PART 7 (max = 100)

Also enter this value on the point calculation table on page 16.

PART 8: FINANCIAL STATUS

- A. Are User-Charge Revenues sufficient to cover operation and maintenance expenses?
✓ Check one box Yes No If no, how are O & M costs being financed?

Explain:

SAME AS B

- B. What financial resources do you have available to pay for your wastewater improvements and reconstruction needs?

WASTEWATER IMPROVEMENTS AND RECONSTRUCTION NEEDS ARE FUNDED FROM FOUR MAIN REVENUE SOURCES. THEY ARE A ONE HALF PERCENT SALES & USE TAX, SEWER USER FEES, SEWER IMPACT FEES, AND A \$4 MILLION SUBSIDY FROM THE GENERAL FUND SUPPORTED FROM GAMING REVENUES.

PART 9: SUBJECTIVE EVALUATION

A. Collection System Maintenance

1. Describe what sewer system maintenance work has been done in the last year.

SEE ATTACHMENT

2. Describe what lift station work has been done in the last year.

ROUTINE MAINTENANCE

3. What collection system improvements does the community have under consideration for the next 5 years?

SEE ATTACHMENT

B. If you have ponds, please answer the following questions:

- | | |
|---|--|
| 1. Do you have duckweed buildup in your ponds? | <input type="checkbox"/> Yes <input type="checkbox"/> No |
| 2. Do you mow your dikes regularly (at least monthly), to the waters edge? | <input type="checkbox"/> Yes <input type="checkbox"/> No |
| 3. Do you have bushes or trees growing on the dikes or in the ponds? | <input type="checkbox"/> Yes <input type="checkbox"/> No |
| 4. Do you have excess sludge buildup (> 1 foot) on the bottom of any of your ponds? | <input type="checkbox"/> Yes <input type="checkbox"/> No |
| 5. Do you exercise all of your valves? | <input type="checkbox"/> Yes <input type="checkbox"/> No |
| 6. Are your control manholes in good structural shape? | <input type="checkbox"/> Yes <input type="checkbox"/> No |
| 7. Do you maintain at least three feet of freeboard in all your ponds? | <input type="checkbox"/> Yes <input type="checkbox"/> No |
| 8. Do you visit your pond system, at least weekly? | <input type="checkbox"/> Yes <input type="checkbox"/> No |

LA0036439 NORTH PLANT

LA MWPP ENVIRONMENTAL AUDIT

PART 9: SUBJECTIVE EVALUATION

A1. AS PART OF THE CONSENT DECREE, OPERATION AND MAINTENANCE OF THE NORTH TREATMENT PLANT COLLECTION AREA IS PERFORMED AND REPORTED ON A QUARTERLY BASIS. THE FOLLOWING TABLE IS A BREAKDOWN/SUMMARY OF ACTIVITIES PERFORMED WITHIN THE NORTH TREATMENT PLANT COLLECTION SYSTEM AREA DURING THE REPORTING PERIOD.

NORTH TREATMENT AREA
MONITORING PERIOD (4/03 ~ 3/04)

LINE CLEANING	23%
CCTV INSPECTIONS	19%
SMOKE TESTING	25%
DYE TESTING	2%
MANHOLE INSPECTION	4%
LINE REPAIRED	6%
MANHOLE REHABILITATION	0.5%
FORCEMAIN-INSPECTIONS	104%
REPAIRED	7%
AIR RELEASE VALVES-INSPECTIONS	189%
REPAIRED	29%
WET WELL CLEANED	79%
PUMP STATIONS-REPAIRED	11%

A3. DURING THE NEXT 5 YEARS APPROXIMATELY 20 PROJECTS IN THE NORTH TREATMENT PLANT COLLECTION AREA (RELATED TO THE SSO CONSENT DECREE PROGRAM) ARE SCHEDULED TO BE IMPLEMENTED. THE PROJECTS WILL INCLUDE PUMPSTATION UPGRADES, FORCEMAIN IMPROVEMENTS, GRAVITY SEWERS, STORAGE AND WET WEATHER TREATMENT FACILITIES. ADDITIONALLY, ANNUAL CONTRACTS FOR SEWER REHABILITATION INCLUDING LINING, POINT REPAIR, UPSIZING, AND OTHER REHABILITATION METHODS WILL ALSO BE IMPLEMENTED.

Facility Name

LA0036439 NORTH PLANT

C. Treatment Plants

1. Have the influent and effluent flow meters been calibrated in the last year? Yes No

Influent flow meter calibration date(s):

Effluent flow meter calibration date(s):

gravity		forcemain		
11-17-04	5-10-05	4-14-04	5/11/05	Final 3-18-05

2. What problems, if any, have been experienced over the last year that have threatened treatment?

Possibly an unknown substance entered the treatment facility, which caused a reduction in treatment efficiency.

3. Is your community presently involved in formal planning for treatment facility upgrading?

Yes No If yes, describe:

D. Preventive Maintenance

1. Does your plant have a written plan for preventive maintenance on major equipment items?

Yes No If yes, describe:

Weekly, monthly and semi-annual preventive maintenance sheets that reflect type and frequency as specified in the O&M manuals. A new computer program will manage the maintenance and preventive maintenance of plant equipment and spare parts.

2. Does this preventive maintenance program depict frequency of intervals, types of lubrication, and other preventive maintenance tasks necessary for each piece of equipment? Yes No
3. Are these preventive maintenance tasks, as well as equipment problems, being recorded and filed so future maintenance problems can be assessed properly? Yes No

E. Sewer Use Ordinance

1. Does your community have a sewer use ordinance that limits or prohibits the discharge of excessive conventional pollutants (BOD, TSS, or pH) or toxic substances to the sewer from industries, commercial users, and residences?

Yes No If yes, describe:

Sewer User Fee Ordinance (No. 7853) limits the discharge of BOD & TSS to 200 mg/l and 250 mg/l respectively. Any discharge above these limits is surcharged at a rate of 2% of the monthly sewer user fee for each limit of 10 mg/l. Pretreatment ordinance (No. 9195) limits the discharge of heavy metals, chemicals and toxic substances.

2. Has it been necessary to enforce? Yes No If yes, describe:

The Sewer User Fee Ordinance is strictly enforced by City-Parish and self monitoring sampling. The same apply to the Pretreatment Ordinance. Enforce mechanisms include discharge permits, surcharges, letter and notice of violations, administrative orders, water termination and fines.

- F. Any additional comments about your treatment plant or collection system? (Attach additional sheet if necessary.)

NO

Facility Name

LA0036439 NORTH PLANT

POINT CALCULATION TABLE

Fill in the values from parts 1 through 7 in the columns below. Add the numbers in the left column to determine the point total that the wastewater system has generated for the previous year.

Actual Values	Actual Values	Maximum
Part 1: Influent Flow/Loadings	<u>0</u>	80 Points
Part 2: Effluent Quality/Plant Performance	<u>60</u>	100 Points
Part 3: Age of WWTT	<u>17.5</u>	50 Points
Part 4: Overflows and Bypasses	<u>50</u>	100 Points
Part 5: Ultimate Disposition of Sludge	<u>10</u>	100 Points
Part 6: New Development	<u>0</u>	30 Points
Part 7: Operator Certification Training	<u>0</u>	100 Points

TOTAL POINTS

137.5

ATTACHMENT 3

SAMPLE MWPP RESOLUTION

Resolved that the city/town of BATON ROUGE informs Louisiana Department of Environmental Quality that the following actions were taken by the CITY/PARISH METROPOLITAN COUNCIL (governing body).

1. Reviewed the Municipal Water Pollution Prevention Environmental Audit Report which is attached to this resolution.
2. Set forth the following actions necessary to maintain permit requirements contained in the Louisiana Water Discharge Permit System (LWDPS) number LA0036439 AI #4843.

(Please be specific in listing the actions that will be taken to address the problems identified in the audit report.)

- a. CURRENTLY, WE ARE OPERATING UNDER A CONSENT DECREE WHICH BECAME EFFECTIVE MARCH 14, 2002.
- b. IMPLEMENTATION OF AGGRESSIVE PROCESS CONTROL STRATEGIES.
- c. A PROJECT IS UNDERWAY TO REDUCE THE HIGH CONCENTRATION OF HYDROGEN SULFIDE (H₂S).
- d.
- etc.

Passed by a majority/unanimous (circle one) vote of the CITY/PARISH METROPOLITAN COUNCIL, on _____ (date).

"Yeas" Messrs: Addison, Boneno, Carter, Culbertson, Greco, Kelly, Sharper, Skyring, Walker, and Mmes. Burgess and Tassin.

"Nays" None.

Absent: Mr. Ourso. 11 yeas, 0 nays, 1 absent, and the motion was adopted.

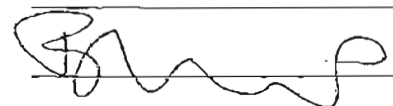
CLERK

CERTIFIED
A TRUE COPY

JUN 15 2005

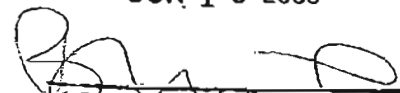
COUNCIL ADMINISTRATOR

ADOPTED
METROPOLITAN COUNCIL

JUN 08 2005

778

RESOLUTION

44187

Brian Maynard
COUNCIL ADMINISTRATOR TREASURER

REQUESTING APPROVAL FOR SUBMITTAL OF THE LOUISIANA MUNICIPAL WATER POLLUTION PREVENTION (MWPP) ENVIRONMENTAL AUDIT REPORT FOR THE NORTH WASTEWATER TREATMENT PLANT TO THE DEPARTMENT OF ENVIRONMENTAL QUALITY (DEQ) FOR THE MONITORING PERIOD OF APRIL 1, 2004 THROUGH MARCH 31, 2005.

BE IT RESOLVED by the Metropolitan Council of the Parish of East Baton Rouge and City of Baton Rouge that the submittal of the Louisiana Municipal Water Pollution Prevention (MWPP) Environmental Audit Report for the North Wastewater Treatment Plant to the Department of Environmental Quality (DEQ) for the monitoring period of April 1, 2004 through March 31, 2005, is hereby approved.

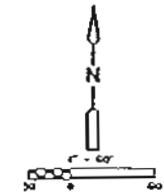
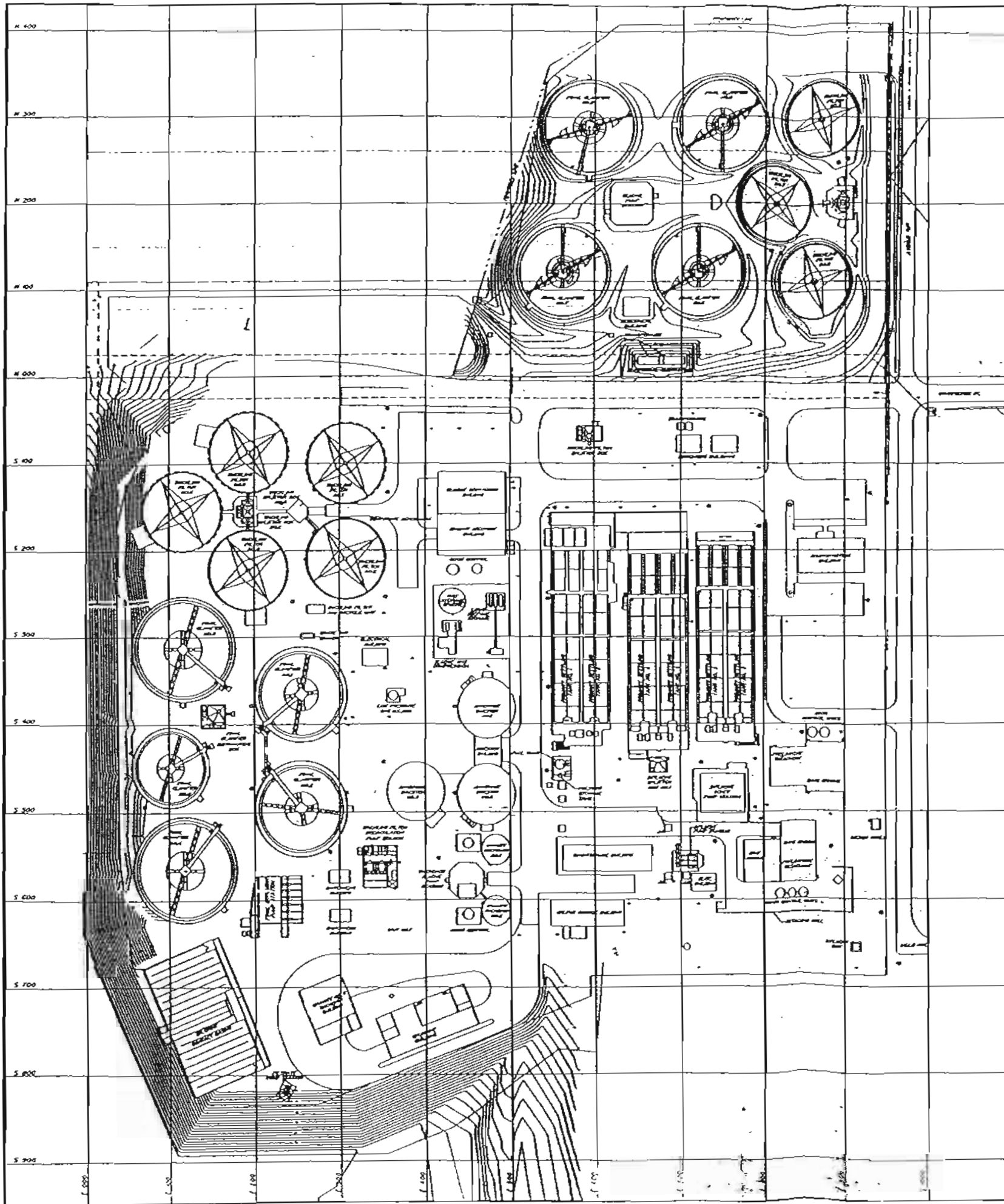

LEADS
 A FROM TEMPORARY MONUMENT ELEV 52.21 WEST SIDE OF SLAB FOR DISCONTINUED PER NO. 2

GENERAL NOTES

1. LOCATION ELEVATIONS AND DIMENSIONS OF EXISTING UTILITIES, STRUCTURES, AND OTHER FEATURES ARE SHOWN ACCORDING TO THE BEST INFORMATION AVAILABLE AT THE TIME OF PREPARATION OF THESE PLANS. BUT DO NOT PURPORT TO BE ABSOLUTELY CORRECT. PRIOR TO CONSTRUCTION THE CONTRACTOR SHALL VERIFY AND BE FULLY RESPONSIBLE FOR ANY AND ALL DAMAGES THAT OCCUR DUE TO CONSTRUCTION OPERATIONS. ANYTHING NOT SHOWN ON THESE DRAWINGS SHOULD BE BROUGHT TO THE ATTENTION OF THE ENGINEER AND SHALL NOT CONSTITUTE AN ERROR UNLESS APPROVED BY THE ENGINEER.
2. THE CONTRACTOR SHALL CONTACT THE ENGINEER'S OFFICE IMMEDIATELY CONCERNING ANY CONFLICTS ARISING DURING CONSTRUCTION OF ANY IMPROVEMENTS SHOWN ON THESE DRAWINGS.
3. THE CONTRACTOR SHALL REPLACE ALL EXISTING STABILIZED EARTH, CURBS, DRIVEWAYS, SIDEWALKS, ETC., WITH THE SAME TYPE OF MATERIAL AND TO THE SAME CONDITION THAT WAS REMOVED OR DISTURBED DURING CONSTRUCTION AT NO ADDITIONAL COST TO THE OWNER.
4. ALL PROSPECTIVE BIDDERS ARE ADVISED, PRIOR TO BIDDING, TO CONDUCT WHATEVER INVESTIGATIONS THEY MAY DEEM NECESSARY TO ARRIVE AT THEIR OWN CONCLUSIONS REGARDING THE ACTUAL CONDITIONS THAT WILL BE ENCOUNTERED, AND UPON WHICH THEIR BIDS WILL BE BASED.
5. TOPOGRAPHIC INFORMATION SHOWN WAS PROVIDED BY PROFESSIONAL ENGINEERING CONSULTANTS' FIRM, SHAW'S & ASSOC. CIVIL, OR PROFESSIONAL ENGINEERING & SURVEYING.
6. FINISHED GRADE FOR GROUND ELEVATIONS OR DRAWINGS REFER TO GRADE AFTER RECONSTRUCTION.
7. SPECIAL PIPE FOUNDATIONS, IF REQUIRED, SHALL BE DETERMINED IN THE FIELD AND THE TYPE REQUIRED WILL BE AS DIRECTED BY THE ENGINEER.
8. ALL PRESSURE PIPE JOINTS AND FITTINGS 6 INCHES IN DIAMETER AND LARGER SHALL HAVE RESTRAINED JOINTS IN ACCORDANCE WITH THE SPECIFICATIONS.
9. ALL FITTINGS 6 INCHES AND LARGER ON DRAINAGE LINES SHALL HAVE RESTRAINED JOINTS IN ACCORDANCE WITH THE SPECIFICATIONS.
10. PIPES UNDERGROUND STRUCTURES AND SLABS SHALL HAVE 6 INCHES MINIMUM CONCRETE ENCASUREMENT FOR PIPES 24 INCHES AND SMALLER, 8 INCHES MINIMUM CONCRETE ENCASUREMENT FOR PIPES LARGER THAN 24 INCHES AND UP TO AND INCLUDING 36 INCHES, AND 9 INCHES MINIMUM CONCRETE ENCASUREMENT FOR PIPES LARGER THAN 36 INCHES. CONCRETE ENCASUREMENT SHALL EXTEND A MINIMUM OF 12 INCHES FROM EDGE OF STRUCTURE OR SLAB. SEE NOTE 8 FOR REINFORCEMENT REQUIREMENTS.
11. PIPES INSTALLED UNDERGROUND STRUCTURES AND ENCASED IN CONCRETE SHALL HAVE THE FOLLOWING REINFORCEMENT:
 - A. PROVIDE 4# @ 12" C/C LONGITUDINALLY, WITH #3 STRAP BANDS AT 12" C/C.
 - B. SHOULD T.O.C. ENCASUREMENT FALL WITHIN 3" FROM UNDERSIDE OF SLAB, THE STRAP BAND SHALL DOUBLE INTO SLAB.
 - C. IF T.O.C. OF ENCASUREMENT IS LOWER THAN 3" FROM UNDERSIDE OF SLAB, ENCASUREMENT WILL BE A SEPARATE SECTION.
 - D. CONCRETE THICKNESS EXCASING THE PIPE IS 6" MINIMUM.
 - E. REINFORCED CONCRETE ENCASUREMENT SHALL EXTEND BEYOND THE OUTER FACE OF THE STRUCTURE AND SHALL TERMINATE AT THE FIRST JOINT WITHIN THE LENGTH OF THE PIPE.
12. THE CONTRACTOR SHALL BE RESPONSIBLE FOR ACTUAL TIE-IN CONNECTIONS TO ALL WATER, RECLAIMED WATER, WASTEWATER, NATURAL GAS AND OTHER LINES AS INDICATED ON THE DRAWINGS.
13. ALL FITTINGS FOR PIPES 3" IN DIAMETER AND LARGER SHALL BE CAST DUCTILE IRON, SHORT BUSH WITH MECHANICAL JOINTS, WITH HIGH STRENGTH CORTEX CORROSION RESISTANT T-HEAD BOLTS, SUBJECT TO THE APPROVAL OF THE ENGINEER.
14. ALL GATE VALVES, UNLESS SPECIFIED, FOR SIZES 4" THROUGH 12" SHALL BE WELDED SEATED GATE VALVES IN CONFORMANCE WITH THE SPECIFICATIONS.
15. SOIL EXPLORATION WORK FOR THIS FACILITY WAS PERFORMED BY LOUIS & CASAZZOLI & ASSOCIATES. SOIL EXPLORATION WORK IS SOLELY TO ASSESS THE NATURE AND EXTENT OF BESTING PROCEDURES REQUIRED TO MAKE THEIR OWN DETERMINATION OF ACTUAL CONDITIONS PRIOR WILL BE ENCOUNTERED DURING THE COURSE OF THE WORK. NO REPRESENTATION IS MADE OR WILL BE GIVEN BY THE ENGINEER CONCERNING ACTUAL CONDITIONS WHICH WILL BE ENCOUNTERED DURING THE COURSE OF THIS WORK AND RECORDS ARE PROVIDED PRIOR TO BIDDING TO CONDUCT WHATEVER INVESTIGATIONS THEY DEEM NECESSARY TO ARRIVE AT THEIR OWN CONCLUSIONS REGARDING SUCH CONDITIONS.
16. DURING EXCAVATIONS, CONTRACTOR SHALL, AS A MINIMUM, COMPLY WITH THE OSHA EXCAVATION SAFETY STANDARDS INCLUDING OCCUPATIONAL SAFETY AND HEALTH ADMINISTRATION EXCAVATION SAFETY STANDARD 29 CFR 1926.650 PART 7 AS AMENDED.
17. ALL FILL SHALL BE COMPACTED TO 90% OF ITS MAXIMUM UNCOMPACTED PROCTOR DRY DENSITY IN ACCORDANCE WITH THE SPECIFICATIONS IN THE GEOLOGICAL REPORT FOR COMPACTION OF CLAY SOILS. THE CLAY SHALL BE A CL MATERIAL.
18. MECHANICAL JOINTS SHOWN ON THE PLANS MAY, AT THE CONTRACTOR'S OPTION, BE SUBSTITUTED WITH PUSH-ON JOINT PIPE. ALL RESTRAINTS, THRUST BLOCKS AS SPECIFIED OR NOTED ON THE DRAWINGS SHALL APPLY, REGARDLESS OF PIPE JOINT TYPE USED.
19. LOCATIONS ARE TO OUTSIDE CORNER OF STRUCTURES OR CENTER OF MANHOLES OR OTHER CIRCULAR STRUCTURES UNLESS NOTED OTHERWISE.

PHASE-1118
 NWTP - EXISTING SITE PLAN
 CITY OF BATON ROUGE / PARISH OF EAST BATON ROUGE

CAMP DRESSER & WOODS, INC. CDM
 ALL CONSULTANTS
 PROFESSIONAL ENGINEERING CONSULTANTS

PROJECT NO.
 24340/1/2
 SHEET NO.
 CN-1





Department of Public Works

City of Baton Rouge
Parish of East Baton Rouge

Post Office Box 1471
Baton Rouge, Louisiana
70821



October 25, 2005

Department of Environmental Quality
Office of Environmental Compliance
Permits Compliance Unit
Post Office Box 4312
Baton Rouge, Louisiana 70821-4312

Re: Municipal Water Pollution Prevention (MWPP) Environmental Audit Report

LPDES PERMIT NUMBER:
LA0036421 AI# 4842

Dear Sirs:

As required by your office, we are submitting the annual Municipal Water Pollution Prevention Environmental Audit report along with the MWPP Resolution. This report represents our Central Wastewater Treatment Plant from September 1, 2004 to August 31, 2005.

If you have any questions concerning this matter, please contact Mr. Charles O'Brien of my staff at (225) 389-3240.

Sincerely yours,

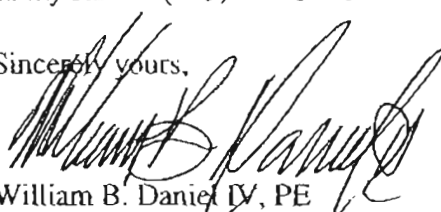

William B. Daniel IV, PE
Interim Director of Public Works

WBD/MO/pas

xc: Jeff Broussard, Deputy Director of Public Works
Richard Wright, PE IV, - DPW- SOGA
Wade Shows, Parish Attorney
Robert Groht, Jr., Wastewater Treatment Plant Manager
Bob Wilks, Wastewater Treatment Process Control Supervisor
Walter Jenkins, Assistant WW Treatment Plant Manager
Garcia Dialekwa, Wastewater Laboratory Supervisor
Cheryl Berry, PE II - DPW - SOGA

Attachment(s):

LOUISIANA

MUNICIPAL WATER POLLUTION PREVENTION

MWPP



Facility Name:

CENTRAL PLANT

LWDPS Permit Number:

NPDES Permit Number:

LA0036421

Address:

2443 RIVER ROAD

BATON ROUGE

LOUISIANA

Parish:

EAST BATON ROUGE

(Person Completing Form) Name:

CHARLES M. O'BRIEN

Title:

ASSISTANT WW LAB SUPERVISOR

Date Completed:

OCTOBER 25, 2005

Instructions to the Operator-in-Charge

- 1. Complete only the sections of the Environmental Audit which apply to your wastewater treatment system. Leave sections that do not apply blank and enter a "0" for the point value.**
- 2. Parts 1 through 7 contain questions for which points may be generated. These points are intended to communicate to the department and the governing body or owner what actions will be necessary to prevent effluent violations. Place the point totals from parts 1 through 7 on the Point Calculation page.**
- 3. Add up the point totals.**
- 4. Submit the Environmental Audit to the governing body or owner for their review and approval.**
- 5. The governing body must pass a resolution which contains the following items:**
 - a. The resolution or letter must acknowledge the governing body or owner has reviewed the Environmental Audit.**
 - b. The resolution must indicate specific actions, if any, will be taken to maintain compliance and prevent effluent violations. Proposed actions should address the parts where maximum or close to maximum points were generated in the Environmental Audit.**
 - c. The resolution should provide any other information the governing body deems appropriate.**

PART 1. INFLUENT FLOW/LOADINGS

Part 1: Influent Flow/Loadings (All plants)

A. List the average monthly volumetric flows and BOD loadings received at your facility during the last reporting year.

Col. 1 Average Monthly Flow (million gallons per day, MGD)		Col. 2 Average Monthly BOD ₅ Concentration (mg/l)		Col. 3 Average Monthly BOD ₅ Loading (pounds per day)
9.21	X	130	X 8.34 =	9,985
11.97	X	122	X 8.34 =	12,179
12.38	X	110	X 8.34 =	11,357
10.18	X	119	X 8.34 =	10,103
10.84	X	118	X 8.34 =	10,668
13.54	X	94	X 8.34 =	10,615
10.17	X	136	X 8.34 =	11,535
9.69	X	141	X 8.34 =	11,395
9.41	X	152	X 8.34 =	11,929
10.41	X	117	X 8.34 =	10,158
9.46	X	129	X 8.34 =	10,178
9.43	X	142	X 8.34 =	11,168

BOD loading = Average Monthly Flow (in MGD) x Average Monthly BOD concentration (in mg/l) x 8.34.

B. List the design flow and design BOD loading for your facility in the blanks below. If you are not aware of these design quantities, refer to your Operation and Maintenance Manual (O & M) or contact your consulting engineer.

Design Flow, MGD	32	X 0.90 =	28.80
Design BOD, lb/day	55,244	X 0.90 =	49,720

Facility Name

LA0036421 CENTRAL PLANT

C. How many months did the monthly flow (Col. 1) to the wastewater treatment plant (WWTP) exceed 90% of design flow?

Circle the number of months and corresponding point total. Write the point total in the box below at the right.

months	0	1	2	3	4	5	6	7	8	9	10	11	12	months
points	0	0	0	0	0	5	5	5	5	5	5	5	5	points

Write 0 or 5 in the C point total box C Point Total

D. How many months did the monthly flow (Col. 1) to the WWTP exceed the design flow?

Circle the number of months and corresponding point total. Write the point total in the box below at the right.

months	0	1	2	3	4	5	6	7	8	9	10	11	12	months
points	0	5	5	10	10	15	15	15	15	15	15	15	15	points

Write 0, 5, 10, or 15 in the D point total box D Point Total

E. How many months did the monthly BOD loading (Col. 3) to the WWTP exceed 90% of the design loading?

Circle the number of months and corresponding point total. Write the point total in the box below at the right.

months	0	1	2	3	4	5	6	7	8	9	10	11	12	months
points	0	0	5	5	5	10	10	10	10	10	10	10	10	points

Write 0, 5, or 10 in the E point total box E Point Total

F. How many times did the monthly BOD loading (Col. 3) to the WWTP exceed the design loading?

Circle the number of months and corresponding point total. Write the point total in the box below at the right.

months	0	1	2	3	4	5	6	7	8	9	10	11	12	months
points	0	10	20	30	40	50	50	50	50	50	50	50	50	points

Write 0, 10, 20, 30, 40, or 50 in the F point total box F Point Total

G. Add together each point total for C through F and place this sum in the box below at the right.

TOTAL POINT VALUE FOR PART 1 (max=80)

Also enter this value on the point calculation table on page 16.

Facility Name

LA0036421 CENTRAL PLANT

PART 2: EFFLUENT QUALITY/PLANT PERFORMANCE

A. List the monthly average effluent BOD and TSS concentrations produced by your facility during the last reporting year.

Month	Column 1 Avg. Monthly BOD (mg/l)	Column 2 Avg. Monthly TSS (mg/l)
SEPTEMBER	18	14
OCTOBER	18	17
NOVEMBER	22	18
DECEMBER	26	17
JANUARY	24	20
FEBRUARY	21	20
MARCH	24	18
APRIL	20	17
MAY	19	14
JUNE	17	16
JULY	22	13
AUGUST	18	19

B. List the monthly average permit limits for your facility in the blanks below.

	Permit Limit		90% of Permit Limit
BOD, mg/l	30	X 0.90 =	27
TSS, mg/l	30	X 0.90 =	27

C. Continuous Discharge to Surface Water

i. How many months did the effluent BOD concentration (Col. 1) exceed 90% of permit limits? Circle the number of months and corresponding point total. Write the point total in the box below at the right.

months	0	1	2	3	4	5	6	7	8	9	10	11	12	months
points	0	0	10	20	30	40	40	40	40	40	40	40	40	points

Write 0, 10, 20, 30 or 40 in the i point total box i Point Total

ii. How many months did the effluent BOD concentration (Col. 1) exceed permit limits? Circle the number of months and corresponding point total. Write the point total in the box below at the right.

months	0	1	2	3	4	5	6	7	8	9	10	11	12	months
points	0	5	5	10	10	10	10	10	10	10	10	10	10	points

Write 0, 5, or 10 in the ii point total box ii Point Total

iii. How many months did the effluent TSS concentration (Col. 2) exceed 90% of permit limits? Circle the number of months and corresponding point total. Write the point total in the box below at the right.

months	0	1	2	3	4	5	6	7	8	9	10	11	12	months
points	0	0	10	20	30	40	40	40	40	40	40	40	40	points

Write 0, 10, 20, 30, or 40 in the iii point total box iii Point Total

iv. How many months did the effluent TSS concentration (Col.2) exceed permit limits? Circle the number of months and corresponding point total. Write the point total in the box below at the right.

months	0	1	2	3	4	5	6	7	8	9	10	11	12	months
points	0	5	5	10	10	10	10	10	10	10	10	10	10	points

Write 0, 5, or 10 in the iv point total box iv Point Total

v. Add together each point total for i through iv and place this sum in the box below at the right.

TOTAL POINT VALUE FOR PART 2 (max=100)
 Also enter this value on the point calculation table on page 16.

Facility Name

LA0036421 CENTRAL PLANT

D. Other Monitoring and Limits

i. At any time in the past year was there an exceedance of a permit limit for other pollutants such as: ammonia-nitrogen, phosphorus, pH, residual chlorine, or fecal coliform?

✓ Check one box Yes No If yes, please describe:

FECAL COLIFORM - 11/23-29/2004 1,585 col./100ml

ii. At any time in the past year was there a "failure" of a Biomonitoring (Whole Effluent Toxicity) test of the effluent?

✓ Check one box Yes No If yes, please describe:

iii. At any time in the past year was there an exceedance of a permit limit for a toxic substance?

✓ Check one box Yes No If yes, please describe:

PART 3: AGE OF THE WASTEWATER TREATMENT FACILITIES

A. What year was the wastewater treatment plant constructed or last major expansion/improvements completed? 1998

Current Year - (Answer to A) = Age in years

$$2005 - 1998 = 7 \text{ years}$$

Enter Age in Part C below.

B. Check the type of treatment facility that is employed:

		Factor
<u>X</u>	Mechanical Treatment Plant (Trickling filter, activated sludge, etc.) Specify Type _____	2.5
_____	Aerated Lagoon	2.0
_____	Stabilization Pond	1.5
_____	Other (Specify) _____	1.0

C. Multiply the factor listed next to the type of facility your community employs by the age of your facility to determine the total point value of Part 3:

$$\text{TOTAL POINT VALUE FOR PART 3} = \frac{2.5}{\text{FACTOR}} \times \frac{7}{\text{AGE}} = \boxed{17.5} \quad (\text{max} = 50)$$

Also enter this value or 50, which ever is less, on the point calculation table on page 16.

D. Please attach a schematic of the treatment plant.

PART 4: OVERFLOWS AND BYPASSES

A. (1) List the number of times in the last year there was an overflow, bypass, or unpermitted discharge of untreated or incompletely treated wastewater due to heavy rain: 0
 (Circle One) **0 = 0 points** 1 = 5 points 2 = 10 points
 3 = 15 points 4 = 30 points 5 or more = 50 points

(2) List the number of bypasses, overflows, or unpermitted discharges shown in A (1) that were within the collection system and the number at the treatment plant.

Collection System 0 Treatment Plant 0

B. (1) List the number of times in the last year there was a bypass or overflow of untreated or incompletely treated wastewater due to equipment failure, either at the treatment plant or due to pumping problems in the collection system: 25
 (Circle One) 0 = 0 points 1 = 5 points **2 = 10 points**
 3 = 15 points 4 = 30 points **5 or more = 50 points**

(2) List the number of bypasses or overflows shown in B (1) that were within the collection system and the number at the treatment plant.

Collection System 24 Treatment Plant 1

C. Specify whether the bypasses came from the city or village sewer system or from contract or tributary communities/sanitary districts, etc.

D. Add the point values circled for A and B and place the total in the box below.

TOTAL POINT VALUE FOR PART 4 50 (max = 100)

Also enter this value on the point calculation table on page 16.

E. List the person responsible for reporting overflows, bypasses, or unpermitted discharges to State and Federal authorities:

Describe the procedure for gathering, compiling, and reporting:

Facility Name

LA0036421 CENTRAL PLANT

PART 5: SLUDGE STORAGE AND DISPOSAL SITES

A. Sludge Storage

How many months of sludge storage capacity does your wastewater treatment facility have available, either on-site or off-site?

Circle the number of months and corresponding point total. Write the point total in the box below at the right.

months	<2	2	3	4 to 5	>6	months
points	50	30	20	10	0	points

Write 0, 10, 20, 30, or 50 in the A point total box A Point Total

B. For how many months does your facility have access to (and approval for) sufficient land disposal sites to provide proper land disposal?

Circle the number of months and corresponding point total. Write the point total in the box below at the right.

months	<2	6 to 11	12 to 23	24 to 35	>36	months
points	50	30	20	10	0	points

Write 0, 10, 20, 30, or 50 in the B point total box B Point Total

C. Add together the A and B point values and place this sum in the box below at the right:

TOTAL POINT VALUE FOR PART 5 (max = 100)

Also enter this value on the point calculation table on page 16.

PART 6: NEW DEVELOPMENT

A. Please provide the following information for the total of all sewer line extensions which were installed during the last year.

Design Population: 0

Design Flow: 0 MGD

Design BOD₅: 190 mg/l

B. Has an industry (or other development) moved into the community or expanded production in the past year, such that either flow or pollutant loadings to the sewerage system were significantly increased (5% or greater)?

(Circle One)

No = 0 points

Yes = 15 points

Describe: _____

List any new pollutants: _____

C. Is there any development (industrial, commercial, or residential) anticipated in the next 2-3 years, such that either flow or pollutant loadings to the sewerage system could significantly increase?

(Circle One)

No = 0 points

Yes = 15 points

Describe: _____

List any new pollutants that you anticipate: _____

D. Add together the point value circled in B and C and place the sum in the blank below.

TOTAL POINT VALUE FOR PART 6 0 (max = 30)

Also enter this value on the point calculation table on page 16.

PART 7: OPERATOR CERTIFICATION AND EDUCATION

- A. What was the name of the operator-in-charge for the reporting year? Robert Florida Name
- B. What is his/her certification number? #10-549 Cert. #
- C. What level of certification is the operator-in-charge required to have to operate the wastewater treatment plant? Wastewater Trmt. IV Level Required
- D. What is the level of certification of the operator-in-charge? Wastewater Trmt. IV Level Certified
- E. Was the operator-in-charge of the report year certified at least at the grade level required in order to operate this plant? Check one box yes = 0 points no = 50 points
Write 0 or 50 in the E point total box 0 E Point Total
- F. Has the operator-in-charge maintained recertification requirements during the reporting year? Check one box yes no
- G. How many hours of continuing education has the operator-in-charge completed over the last two calendar years? Check one box 12 hours or more = 0 points Less than 12 hours = 50 points
Write 0 or 50 in the G point total box 0 G Point Total
- H. Is there a written policy regarding continuing education and training for wastewater treatment plant employees? Check one box yes no

Explain:

The State of Louisiana requires that an operator have at least 16 hours of continuing education in a two-year period to maintain his/her certification.

- I. What percentage of the continuing education expenses of the operator-in-charge were paid for:
By the permittee? 100%
By the operator? 0%
- J. Add together the E and G point values and place this sum in the box below at the right:

TOTAL POINT VALUE FOR PART 7 0 (max=100)

Also enter this value on the point calculation table on page 16.

Facility Name

LA0036421 CENTRAL PLANT

PART 8: FINANCIAL STATUS

- A. Are User-Charge Revenues sufficient to cover operation and maintenance expenses?
✓ Check one box Yes No If no, how are O & M costs being financed?

Explain:

SAME AS B.

- B. What financial resources do you have available to pay for your wastewater improvements and reconstruction needs?

WASTEWATER IMPROVEMENTS AND RECONSTRUCTION NEEDS ARE FUNDED FROM FOUR MAIN REVENUE SOURCES. THEY ARE A ONE HALF PERCENT SALES & USE TAX, SEWER USER FEES, SEWER IMPACT FEE, AND A \$4 MILLION SUBSIDY FROM THE GENERAL FUND SUPPORTED FROM GAMING REVENUES.

PART 9: SUBJECTIVE EVALUATION

A. Collection System Maintenance

1. Describe what sewer system maintenance work has been done in the last year.

SEE ATTACHMENT

2. Describe what lift station work has been done in the last year.

Replacement and repairs of the Force Main on the discharge side of the pump station up to the 4' level of the existing gravity lines and routine maintenance work.

3. What collection system improvements does the community have under consideration for the next 5 years?

SEE ATTACHMENT

B. If you have ponds, please answer the following questions:

- 1. Do you have duckweed buildup in your ponds? Yes No
- 2. Do you mow your dikes regularly (at least monthly), to the waters edge? Yes No
- 3. Do you have bushes or trees growing on the dikes or in the ponds? Yes No
- 4. Do you have excess sludge buildup (> 1 foot) on the bottom of any of your ponds? Yes No
- 5. Do you exercise all of your valves? Yes No
- 6. Are your control manholes in good structural shape? Yes No
- 7. Do you maintain at least three feet of freeboard in all your ponds? Yes No
- 8. Do you visit your pond system, at least weekly? Yes No

LA0036421 CENTRAL PLANT

LA MWPP Environmental Audit

Part 9: Subjective Evaluation

A1. As part of the Consent Decree, Operation and Maintenance of the Central Treatment Plant Collection Area is performed and reported on a quarterly basis. The following table is a breakdown / summary of activities performed within the Central Treatment Plant Collection System Area during the reporting period.

Central Treatment Area
Monitoring Period (9/04- 8/05)

Line Cleaned	7%
CCTV Inspected	3%
Smoke Tested	20%
Dye Tested	53%
Manhole Inspected	10%
Line Repaired	6%
Manhole Rehabilitated	0.8%
Force Main – Inspected	0%
Repaired	0%
Air Release Valves – Inspected	0%
Repaired	0%
Wet Wells Cleaned	100%
Pump Stations - Repaired	81%

A3. During the next 5 years, approximately 6 projects in the Central Treatment Plant Collection Area (related to the SSO Consent Decree Program) are scheduled to be implemented. The projects will include pump stations upgrades, force main improvements, gravity sewers, storage, and wet weather treatment facilities. Additionally, annual contracts for sewer rehabilitation including lining, point repair, upsizing, and other rehabilitation methods will also be implemented.

Future Central Wastewater Treatment Plant Collection System Improvements

Description
Pump Station 59 Area Upgrades
Pump Station 23 & 60 Area Upgrades
Pump Station 1/Pump Station 2/Pump Station 10 Area Upgrades
Pump Station 5 Area Upgrades
Pump Station 4 Area Upgrades
Pump Station 15/Pump Station 48/Pump Station 60 Area Upgrades

Facility Name

LA0036421 CENTRAL PLANT

C. Treatment Plants

1. Have the influent and effluent flow meters been calibrated in the last year? Yes No

Influent flow meter calibration date(s):

Effluent flow meter calibration date(s):

11/19/04 05/19/05	09/29/04 02/11/05 07/29/05
-------------------	----------------------------

2. What problems, if any, have been experienced over the last year that have threatened treatment?

NONE

3. Is your community presently involved in formal planning for treatment facility upgrading?

Yes No If yes, describe:

D. Preventive Maintenance

1. Does your plant have a written plan for preventive maintenance on major equipment items?

Yes No If yes, describe:

Weekly, monthly and semi-annual preventive maintenance sheets that reflect type and frequency as specified in the O&M manuals. A new computer program will manage the maintenance and preventive maintenance of plant equipment and spare parts.

2. Does this preventive maintenance program depict frequency of intervals, types of lubrication, and other preventive maintenance tasks necessary for each piece of equipment? Yes No

3. Are these preventive maintenance tasks, as well as equipment problems, being recorded and filed so future maintenance problems can be assessed properly? Yes No

E. Sewer Use Ordinance

1. Does your community have a sewer use ordinance that limits or prohibits the discharge of excessive conventional pollutants (BOD, TSS, or pH) or toxic substances to the sewer from industries, commercial users, and residences?

Yes No If yes, describe:

Sewer User Fee Ordinance (No. 7853) limits the discharge of BOD & TSS to 200 mg/l and 250 mg/l respectively. Any discharge above these limits is surcharged at a rate of 2% of the monthly sewer user fee for each limit of 10 mg/l. Pretreatment Ordinance (No. 9195) limits the discharge of heavy metals, chemicals and toxic substances.

2. Has it been necessary to enforce? Yes No If yes, describe:

The Sewer User Fee Ordinance is strictly enforced by City-Parish and self monitoring sampling. The same apply to the Pretreatment Ordinance. Enforce mechanisms include discharge permits, surcharges, letter and notice of violations, administrative orders, water termination and fines.

F. Any additional comments about your treatment plant or collection system? (Attach additional sheet if necessary.)

NO

Facility Name

LA0036421 CENTRAL PLANT

POINT CALCULATION TABLE

Fill in the values from parts 1 through 7 in the columns below. Add the numbers in the left column to determine the point total that the wastewater system has generated for the previous year.

Actual Values	Actual Values	Maximum
Part 1: Influent Flow/Loadings	0	80 Points
Part 2: Effluent Quality/Plant Performance	0	100 Points
Part 3: Age of WWTT	17.5	50 Points
Part 4: Overflows and Bypasses	50	100 Points
Part 5: Ultimate Disposition of Sludge	10	100 Points
Part 6: New Development	0	30 Points
Part 7: Operator Certification Training	0	100 Points

TOTAL POINTS

77.5

ATTACHMENT 3

SAMPLE MWPP RESOLUTION

Resolved that the city/town of BATON ROUGE informs Louisiana Department of Environmental Quality that the following actions were taken by the CITY/PARISH METROPOLITAN COUNCIL (governing body).

1. Reviewed the Municipal Water Pollution Prevention Environmental Audit Report which is attached to this resolution.
2. Set forth the following actions necessary to maintain permit requirements contained in the Louisiana Water Discharge Permit System (LWDPS) number LA0036421 AI# 4842.

(Please be specific in listing the actions that will be taken to address the problems identified in the audit report.)

- a. CURRENTLY, WE ARE OPERATING UNDER A CONSENT DECREE WHICH BECAME EFFECTIVE MARCH 14, 2002.
- b.
- c.
- d.
- etc.

Passed by a majority/unanimous (circle one) vote of the CITY/PARISH METROPOLITAN COUNCIL on NOVEMBER 9, 2005 (date).

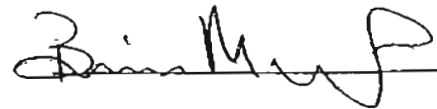

CLERK

ADOPTED
METROPOLITAN COUNCIL

NOV 09 2005

202

RESOLUTION 44486 *Brian Maynard*
COUNCIL ADMINISTRATOR TREASURER

REQUESTING APPROVAL FOR SUBMITTAL OF THE LOUISIANA MUNICIPAL WATER POLLUTION PREVENTION (MWPP) ENVIRONMENTAL AUDIT REPORT FOR THE CENTRAL WASTEWATER TREATMENT PLANT TO THE DEPARTMENT OF ENVIRONMENTAL QUALITY (DEQ) FOR THE MONITORING PERIOD OF SEPTEMBER 1, 2004 THROUGH AUGUST 31, 2005.

BE IT RESOLVED by the Metropolitan Council of the Parish of East Baton Rouge and City of Baton Rouge that the submittal of the Louisiana Municipal Water Pollution Prevention (MWPP) Environmental Audit Report for the Central Wastewater Treatment Plant to the Department of Environmental Quality (DEQ) for the monitoring period of September 1, 2004 through August 31, 2005, is hereby approved.

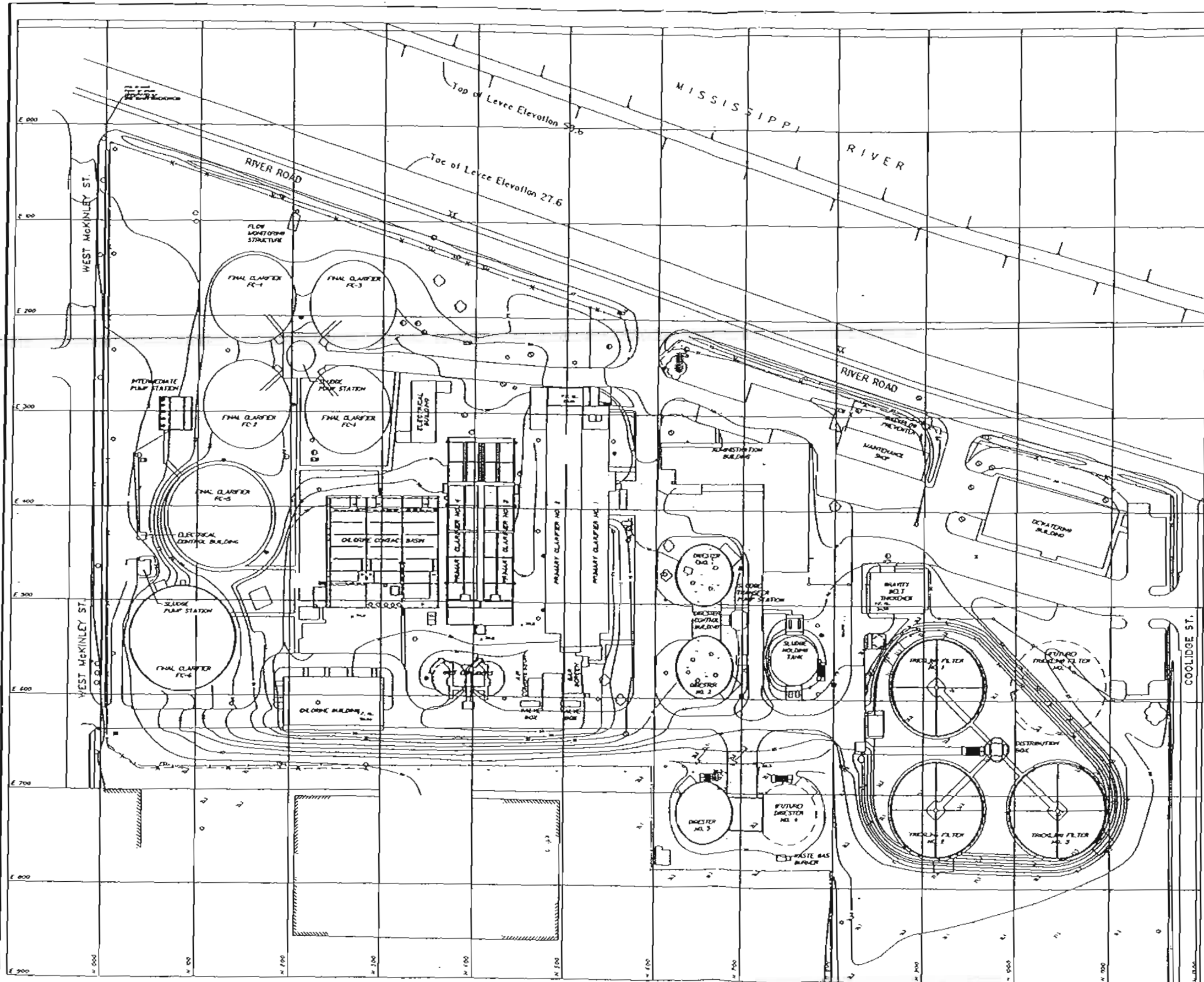

LEGEND

▲ T.M. TEMPORARY BENCHMARK ELEV 52.77 WEST SIDE OF SLAB FOR TROUBLE SHOOTER NO. 2

GENERAL NOTES

1. LOCATION ELEVATIONS AND DIMENSIONS OF EXISTING UTILITIES, STRUCTURES, AND OTHER FEATURES ARE SHOWN ACCORDING TO THE BEST INFORMATION AVAILABLE AT THE TIME OF PREPARATION OF THESE PLANS. BUT DO NOT SUPPORT TO BE ABSOLUTELY CORRECT. PRIOR TO CONSTRUCTION, THE CONTRACTOR SHALL VERIFY AND AGREE TO BE FULLY RESPONSIBLE FOR ANY AND ALL DAMAGES THAT OCCUR DUE TO CONSTRUCTION OPERATIONS. ANYTHING NOT SHOWN ON THESE DRAWINGS SHOULD BE BROUGHT TO THE ATTENTION OF THE ENGINEER AND SHALL NOT CONSTITUTE AN ERROR, UNLESS APPROVED BY THE ENGINEER.
2. THE CONTRACTOR SHALL CONTACT THE ENGINEER'S OFFICE IMMEDIATELY CONCERNING ANY CONFLICTS ARISING DURING CONSTRUCTION OF ANY IMPROVEMENTS SHOWN ON THESE DRAWINGS.
3. THE CONTRACTOR SHALL REPLACE ALL EXISTING STABILIZED EARTH CURVES, DRIVEWAYS, SIDEWALKS, ETC., WITH THE SAME TYPE OF MATERIAL AND TO THE SAME CONDITION THAT WAS REMOVED OR DISTURBED DURING CONSTRUCTION AT NO ADDITIONAL COST TO THE OWNER.
4. ALL PROSPECTIVE BIDDERS ARE DIRECTED, PRIOR TO BIDDING, TO CONDUCT WHATEVER INVESTIGATIONS THEY MAY DEEM NECESSARY TO ARRIVE AT THEIR OWN CONCLUSIONS REGARDING THE ACTUAL CONDITIONS THAT WILL BE ENCOUNTERED, AND UPON WHICH THEIR BIDS WILL BE BASED.
5. TOPOGRAPHIC INFORMATION SHOWN WAS PROVIDED BY PROFESSIONAL ENGINEERING CONSULTANTS PELL, SHAWKHO & BARRY & ASSOC. (SAB) OF FRENCH LAKES, MISSISSIPPI.
6. FINISHED GRADE FOR BOUND ELEVATIONS ON DRAWINGS REFER TO GRADE AFTER SOCCING.
7. SPECIAL PIPE FOUNDATIONS, IF REQUIRED, SHALL BE DETERMINED IN THE FIELD AND THE TYPE REQUIRED WILL BE AS DIRECTED BY THE ENGINEER.
8. ALL PRESSURE PIPE JOINTS AND FITTINGS 4 INCHES IN DIAMETER AND LARGER SHALL HAVE RESTRAINED JOINTS IN ACCORDANCE WITH THE SPECIFICATIONS.
9. ALL FITTINGS 6 INCHES AND LARGER ON GRAVITY LINES SHALL HAVE RESTRAINED JOINTS IN ACCORDANCE WITH THE SPECIFICATIONS.
10. PIPES UNDERNEATH STRUCTURES AND SLABS SHALL HAVE 6 INCHES MINIMUM CONCRETE ENCASUREMENT FOR PIPES 24 INCHES AND SMALLER, 8 INCHES MINIMUM CONCRETE ENCASUREMENT FOR PIPES LARGER THAN 24 INCHES AND UP TO AND INCLUDING 36 INCHES, AND 9 INCHES MINIMUM CONCRETE ENCASUREMENT FOR PIPES LARGER THAN 36 INCHES. CONCRETE ENCASUREMENT SHALL EXTEND A MINIMUM OF 12 INCHES PAST EDGE OF STRUCTURE OR SLAB. (SEE NOTE # 8 FOR REINFORCEMENT REQUIREMENTS)
11. PIPES INSTALLED UNDERNEATH STRUCTURES AND ENCASED IN CONCRETE SHALL HAVE THE FOLLOWING REINFORCEMENT:
 - A. PROVIDE #5 AT 12" O.C. LONGITUDINALLY, WITH #5 STRIP BARS AT 12" O.C.
 - B. SHALL HAVE ENCASUREMENT FALL WITHIN 3" FROM UNDERSIDE OF SLAB. THE STRIP BARS SHALL BEND INTO SLAB.
 - C. IF SLOPE OF ENCASUREMENT IS LOWER THAN 3" FROM UNDERSIDE OF SLAB, ENCASUREMENT WILL BE A JOINTLESS SECTION.
 - D. CONCRETE THICKNESS ENCASE THE PIPE IS 6" MINIMUM.
 - E. REINFORCED CONCRETE ENCASUREMENT SHALL EXTEND BEYOND THE OUTER FACE OF THE STRUCTURE AND SHALL TERMINATE AT THE FIRST JOINT WITHIN THE LENGTH OF THE PIPE.
12. THE CONTRACTOR SHALL BE RESPONSIBLE FOR ACTUAL, Y-E-H CONNECTIONS TO ALL WATER, RECLAIMED WATER, WASTEWATER, NATURAL GAS AND OTHER LINES AS SHOWN ON THE DRAWINGS.
13. ALL FITTINGS FOR PIPES 3 INCH DIAMETER AND LARGER SHALL BE CAST IRON/DUCTILE IRON (SDI) BODY WITH MECHANICAL JOINTS WITH HIGH STRENGTH CORROSION RESISTANT T-HEAD BOLTS, SUBJECT TO THE APPROVAL OF THE ENGINEER.
14. ALL GATE VALVES WHERE SPECIFIED FOR SIZES 4" THROUGH 12" SHALL BE RESILIENT SEATED GATE VALVES IN CONFORMANCE WITH THE SPECIFICATIONS.
15. SOILS EXPLORATION WORK FOR THIS PROJECT WAS PERFORMED BY LOUIS J. CARROLL & ASSOCIATES. SOIL EXPLORATION WORK IS SOLELY TO ASSIST BIDDERS IN ASSESSING THE NATURE AND EXTENT OF TESTING PROCEDURES REQUIRED TO MAKE THEIR OWN DETERMINATION OF ACTUAL CONDITIONS WHICH WILL BE ENCOUNTERED DURING THE COURSE OF THE WORK. NO REPRESENTATION IS MADE OR WILL BE GIVEN BY THE ENGINEER CONCERNING ACTUAL CONDITIONS WHICH WILL BE ENCOUNTERED DURING THE COURSE OF THIS WORK AND BIDDERS ARE DIRECTED, PRIOR TO BIDDING, TO CONDUCT WHATEVER INVESTIGATIONS THEY DEEM NECESSARY TO ARRIVE AT THEIR OWN CONCLUSIONS REGARDING SUCH CONDITIONS.
16. DURING EXCAVATION, CONTRACTOR SHALL:
 - A. AS A MINIMUM, COMPLY WITH THE OSHA EXCAVATION SAFETY STANDARDS INCLUDING OCCUPATIONAL SAFETY AND HEALTH ADMINISTRATION EXCAVATION SAFETY STANDARD 29 CFR 1926.650 SUBPART F AS AMENDED.
 - B. ALL FILL SHALL BE COMPACTED TO 90% OF ITS MAXIMUM MODIFIED PROCTOR DRY DENSITY IN ACCORDANCE WITH THE SPECIFICATIONS IN THE GEOTECHNICAL REPORT FOR COMPACTION OF CLAY SOILS. THE CLAY SHALL BE A CL MATERIAL.
 - C. MECHANICAL JOINTS SHOWN ON THE PLANS MAY, AT THE CONTRACTOR'S OPTION, BE SUBSTITUTED WITH PUSH-ON JOINT PIPE. ALL RESTRAINTS, TARGET BLOCKS AS SPECIFIED OR NOTED ON THE DRAWINGS WILL APPLY, REGARDLESS OF PIPE JOINT TYPE USED.
 - D. LOCATIONS ARE TO OBTAIN CORNER OF STRUCTURES OR CENTER OF MANHOLES OR OTHER CIRCULAR STRUCTURES UNLESS NOTED OTHERWISE.

PHASE-III
CWTP-EXISTING SITE PLAN
CITY OF BATON ROUGE / PARISH OF EAST BATON ROUGE

PROJECT NO.	24340/1/7	DATE	1/17/20	DRAWN BY	J. HAYES
PROJECT NO.	24340/1/7	DATE	1/17/20	CHECKED BY	J. HAYES
PROJECT NO.	24340/1/7	DATE	1/17/20	DESIGNED BY	J. HAYES
PROJECT NO.	24340/1/7	DATE	1/17/20	APPROVED BY	J. HAYES

AUSTIN S. HAYES, JR.
No. 25321
PROFESSIONAL ENGINEER
STATE OF LOUISIANA

DC



Department of Public Works

City of Baton Rouge
Parish of East Baton Rouge

Post Office Box 1471
Baton Rouge, Louisiana
70821

RECEIVED
SEP 16 2005
Sewer Operations
General Administration

August 4, 2005

Department of Environmental Quality
Office of Environmental Compliance
Permits Compliance Unit
Post Office Box 4312
Baton Rouge, Louisiana 70821-4312

Re: Municipal Water Pollution Prevention (MWPP) Environmental Audit Report

LPDES PERMIT NUMBER:
LA0036412 AI# 4841

Dear Sirs:

As required by your office, we are submitting the annual Municipal Water Pollution Prevention Environmental Audit report along with the MWPP Resolution. This report represents our South Wastewater Treatment Plant from June 1, 2004 to May 31, 2005.

If you have any questions concerning this matter, please contact Mr. Charles O'Brien of my staff at (225) 389-3240.

Sincerely yours,

FOR William B. Daniel IV, PE
Interim Director of Public Works

WBD/MO/pas

- xc: Jeff Broussard, Deputy Director of Public Works
- Richard Wright, PE IV, - DPW- SOGA
- Michael Ponder, Parish Attorney
- Robert Groht, Jr., Wastewater Treatment Plant Manager
- Bob Wilks, Wastewater Treatment Process Control Supervisor
- Walter Jenkins, Assistant WW Treatment Plant Manager
- Garcia Dialekwa, Wastewater Laboratory Supervisor
- Cheryl Berry, PE II - DPW - SOGA

Attachment(s):

LOUISIANA

MUNICIPAL WATER POLLUTION PREVENTION

MWPP



Facility Name:

SOUTH PLANT

LWDPS Permit Number:

NPDES Permit Number:

LA0036412 AI# 4841

Address:

2850 GARDERE LANE

BATON ROUGE

LOUISIANA

Parish:

EAST BATON ROUGE

(Person Completing Form) Name:

CHARLES M. O'BRIEN

Title:

ASSISTANT WW LAB SUPERVISOR

Date Completed:

AUGUST 4, 2005

Instructions to the Operator-in-Charge

- 1. Complete only the sections of the Environmental Audit which apply to your wastewater treatment system. Leave sections that do not apply blank and enter a "0" for the point value.**
- 2. Parts 1 through 7 contain questions for which points may be generated. These points are intended to communicate to the department and the governing body or owner what actions will be necessary to prevent effluent violations. Place the point totals from parts 1 through 7 on the Point Calculation page.**
- 3. Add up the point totals.**
- 4. Submit the Environmental Audit to the governing body or owner for their review and approval.**
- 5. The governing body must pass a resolution which contains the following items:**
 - a. The resolution or letter must acknowledge the governing body or owner has reviewed the Environmental Audit.**
 - b. The resolution must indicate specific actions, if any, will be taken to maintain compliance and prevent effluent violations. Proposed actions should address the parts where maximum or close to maximum points were generated in the Environmental Audit.**
 - c. The resolution should provide any other information the governing body deems appropriate.**

PART 1: INFLUENT FLOW/LOADINGS

Part 1: Influent Flow/Loadings (All plants)

A. List the average monthly volumetric flows and BOD loadings received at your facility during the last reporting year.

Col. 1 Average Monthly Flow (million gallons per day, MGD)	X	Col. 2 Average Monthly BOD ₅ Concentration (mg/l)	X 8.34 =	Col. 3 Average Monthly BOD ₅ Loading (pounds per day)
39.70	X	120	X 8.34 =	39,732
32.80	X	127	X 8.34 =	34,741
27.89	X	147	X 8.34 =	34,192
26.96	X	148	X 8.34 =	33,277
32.45	X	125	X 8.34 =	33,829
34.60	X	128	X 8.34 =	36,936
31.69	X	142	X 8.34 =	37,530
32.40	X	139	X 8.34 =	37,560
36.71	X	118	X 8.34 =	36,127
30.84	X	141	X 8.34 =	36,266
30.92	X	153	X 8.34 =	39,454
29.29	X	151	X 8.34 =	36,886

BOD loading = Average Monthly Flow (in MGD) x Average Monthly BOD concentration (in mg/l) x 8.34.

B. List the design flow and design BOD loading for your facility in the blanks below. If you are not aware of these design quantities, refer to your Operation and Maintenance Manual (O & M) or contact your consulting engineer.

Design Flow, MGD	54	X 0.90 =	48.60
Design BOD, lb/day	93,224	X 0.90 =	83,902

C. How many months did the monthly flow (Col. 1) to the wastewater treatment plant (WWTP) exceed 90% of design flow?

Circle the number of months and corresponding point total. Write the point total in the box below at the right.

months	0	1	2	3	4	5	6	7	8	9	10	11	12	months
points	0	0	0	0	0	5	5	5	5	5	5	5	5	points

Write 0 or 5 in the C point total box C Point Total

D. How many months did the monthly flow (Col. 1) to the WWTP exceed the design flow?

Circle the number of months and corresponding point total. Write the point total in the box below at the right.

months	0	1	2	3	4	5	6	7	8	9	10	11	12	months
points	0	5	5	10	10	15	15	15	15	15	15	15	15	points

Write 0, 5, 10, or 15 in the D point total box D Point Total

E. How many months did the monthly BOD loading (Col. 3) to the WWTP exceed 90% of the design loading?

Circle the number of months and corresponding point total. Write the point total in the box below at the right.

months	0	1	2	3	4	5	6	7	8	9	10	11	12	months
points	0	0	5	5	5	10	10	10	10	10	10	10	10	points

Write 0, 5, or 10 in the E point total box E Point Total

F. How many times did the monthly BOD loading (Col. 3) to the WWTP exceed the design loading?

Circle the number of months and corresponding point total. Write the point total in the box below at the right.

months	0	1	2	3	4	5	6	7	8	9	10	11	12	months
points	0	10	20	30	40	50	50	50	50	50	50	50	50	points

Write 0, 10, 20, 30, 40, or 50 in the F point total box F Point Total

G. Add together each point total for C through F and place this sum in the box below at the right.

TOTAL POINT VALUE FOR PART 1 (max=80)

Also enter this value on the point calculation table on page 16.

PART 2: EFFLUENT QUALITY/PLANT PERFORMANCE

A. List the monthly average effluent BOD and TSS concentrations produced by your facility during the last reporting year.

Month	Column 1 Avg. Monthly BOD (mg/l)	Column 2 Avg. Monthly TSS (mg/l)
JUNE	38	32
JULY	35	28
AUGUST	41	30
SEPTEMBER	41	32
OCTOBER	41	34
NOVEMBER	35	34
DECEMBER	48	34
JANUARY	44	36
FEBRUARY	44	38
MARCH	51	38
APRIL	47	34
MAY	43	29

B. List the monthly average permit limits for your facility in the blanks below.

	Permit Limit		90% of Permit Limit
BOD, mg/l	30	X 0.90 =	27
TSS, mg/l	30	X 0.90 =	27

C. Continuous Discharge to Surface Water

i. How many months did the effluent BOD concentration (Col. 1) exceed 90% of permit limits? Circle the number of months and corresponding point total. Write the point total in the box below at the right.

months	0	1	2	3	4	5	6	7	8	9	10	11	12	months
points	0	0	10	20	30	40	40	40	40	40	40	40	40	points

Write 0, 10, 20, 30 or 40 in the i point total box i Point Total

ii. How many months did the effluent BOD concentration (Col. 1) exceed permit limits? Circle the number of months and corresponding point total. Write the point total in the box below at the right.

months	0	1	2	3	4	5	6	7	8	9	10	11	12	months
points	0	5	5	10	10	10	10	10	10	10	10	10	10	points

Write 0, 5, or 10 in the ii point total box ii Point Total

iii. How many months did the effluent TSS concentration (Col. 2) exceed 90% of permit limits? Circle the number of months and corresponding point total. Write the point total in the box below at the right.

months	0	1	2	3	4	5	6	7	8	9	10	11	12	months
points	0	0	10	20	30	40	40	40	40	40	40	40	40	points

Write 0, 10, 20, 30, or 40 in the iii point total box iii Point Total

iv. How many months did the effluent TSS concentration (Col.2) exceed permit limits? Circle the number of months and corresponding point total. Write the point total in the box below at the right.

months	0	1	2	3	4	5	6	7	8	9	10	11	12	months
points	0	5	5	10	10	10	10	10	10	10	10	10	10	points

Write 0, 5, or 10 in the iv point total box iv Point Total

v. Add together each point total for i through iv and place this sum in the box below at the right.

TOTAL POINT VALUE FOR PART 2 (max=100)
 Also enter this value on the point calculation table on page 16.

Facility Name

LA0036412 SOUTH PLANT

D. Other Monitoring and Limits

i. At any time in the past year was there an exceedance of a permit limit for other pollutants such as: ammonia-nitrogen, phosphorus, pH, residual chlorine, or fecal coliform?

✓ Check one box Yes No If yes, please describe:

FECAL COLIFORM - 10/5-11/2004 998 COL./100ML

FECAL COLIFORM - 11/23-29/2004 1,585 COL./100ML

FECAL COLIFORM - 05/3-9/2005 489 COL./100ML

ii. At any time in the past year was there a "failure" of a Biomonitoring (Whole Effluent Toxicity) test of the effluent?

✓ Check one box Yes No If yes, please describe:

iii. At any time in the past year was there an exceedance of a permit limit for a toxic substance?

✓ Check one box Yes No If yes, please describe:

PART 3: AGE OF THE WASTEWATER TREATMENT FACILITIES

A. What year was the wastewater treatment plant constructed or last major expansion/improvements completed? 1998

Current Year - (Answer to A) = Age in years
2005 - 1998 = 7 years

Enter Age in Part C below.

B. Check the type of treatment facility that is employed:

		Factor
<u>X</u>	Mechanical Treatment Plant (Trickling filter, activated sludge, etc.) Specify Type <u>Trickling Filter</u>	2.5
_____	Aerated Lagoon	2.0
_____	Stabilization Pond	1.5
_____	Other (Specify) _____	1.0

C. Multiply the factor listed next to the type of facility your community employs by the age of your facility to determine the total point value of Part 3:

TOTAL POINT VALUE FOR PART 3 = $\frac{2.5}{\text{FACTOR}} \times \frac{7}{\text{AGE}} = \boxed{17.5}$ (max = 50)

Also enter this value or 50, which ever is less, on the point calculation table on page 16.

D. Please attach a schematic of the treatment plant.

PART 4: OVERFLOWS AND BYPASSES

A. (1) List the number of times in the last year there was an overflow, bypass, or unpermitted discharge of untreated or incompletely treated wastewater due to heavy rain: 20
 (Circle One) 0 = 0 points 1 = 5 points 2 = 10 points
 3 = 15 points 4 = 30 points 5 or more = 50 points

(2) List the number of bypasses, overflows, or unpermitted discharges shown in A (1) that were within the collection system and the number at the treatment plant.

Collection System 20 Treatment Plant 0

B. (1) List the number of times in the last year there was a bypass or overflow of untreated or incompletely treated wastewater due to equipment failure, either at the treatment plant or due to pumping problems in the collection system: 70
 (Circle One) 0 = 0 points 1 = 5 points 2 = 10 points
 3 = 15 points 4 = 30 points 5 or more = 50 points

(2) List the number of bypasses or overflows shown in B (1) that were within the collection system and the number at the treatment plant.

Collection System 70 Treatment Plant 0

C. Specify whether the bypasses came from the city or village sewer system or from contract or tributary communities/sanitary districts, etc.

D. Add the point values circled for A and B and place the total in the box below.

TOTAL POINT VALUE FOR PART 4 100 (max=100)

Also enter this value on the point calculation table on page 16.

E. List the person responsible for reporting overflows, bypasses, or unpermitted discharges to State and Federal authorities:

CHARLES M. O'BRIEN, ASSISTANT WASTEWATER LABORATORY SUPERVISOR
 (225) 389-3240

Describe the procedure for gathering, compiling, and reporting:

THE PROCEDURE FOR GATHERING, COMPILING, AND REPORTING IS SPECIFIED IN THE PERMIT.

PART 5: SLUDGE STORAGE AND DISPOSAL SITES

A. Sludge Storage

How many months of sludge storage capacity does your wastewater treatment facility have available, either on-site or off-site?

Circle the number of months and corresponding point total. Write the point total in the box below at the right.

months	<2	2	3	4 to 5	>6	months
points	50	30	20	10	0	points

Write 0, 10, 20, 30, or 50 in the A point total box A Point Total

B. For how many months does your facility have access to (and approval for) sufficient land disposal sites to provide proper land disposal?

Circle the number of months and corresponding point total. Write the point total in the box below at the right.

months	<2	6 to 11	12 to 23	24 to 35	>36	months
points	50	30	20	10	0	points

Write 0, 10, 20, 30, or 50 in the B point total box B Point Total

C. Add together the A and B point values and place this sum in the box below at the right:

TOTAL POINT VALUE FOR PART 5 (max = 100)

Also enter this value on the point calculation table on page 16.

PART 6: NEW DEVELOPMENT

A. Please provide the following information for the total of all sewer line extensions which were installed during the last year.

Design Population: 9,441
 Design Flow: 4.07 MGD
 Design BOD₅: 190 mg/l

B. Has an industry (or other development) moved into the community or expanded production in the past year, such that either flow or pollutant loadings to the sewerage system were significantly increased (5% or greater)?

(Circle One) No = 0 points Yes = 15 points

Describe: _____

List any new pollutants: _____

C. Is there any development (industrial, commercial, or residential) anticipated in the next 2-3 years, such that either flow or pollutant loadings to the sewerage system could significantly increase?

(Circle One) No = 0 points Yes = 15 points

Describe: _____

List any new pollutants that you anticipate: _____

D. Add together the point value circled in B and C and place the sum in the blank below.

TOTAL POINT VALUE FOR PART 6 0 (max = 30)

Also enter this value on the point calculation table on page 16.

PART 7: OPERATOR CERTIFICATION AND EDUCATION

- A. What was the name of the operator-in-charge for the reporting year? HUGH TAYLOR Name
- B. What is his/her certification number? 10-628 Cert. #
- C. What level of certification is the operator-in-charge required to have to operate the wastewater treatment plant? WASTEWATER TRMT. IV Level Required
- D. What is the level of certification of the operator-in-charge? WASTEWATER TRMT. IV Level Certified
- E. Was the operator-in-charge of the report year certified at least at the grade level required in order to operate this plant? Check one box yes = 0 points no = 50 points
Write 0 or 50 in the E point total box 0 E Point Total
- F. Has the operator-in-charge maintained recertification requirements during the reporting year? Check one box yes no
- G. How many hours of continuing education has the operator-in-charge completed over the last two calendar years? Check one box 12 hours or more = 0 points Less than 12 hours = 50 points
Write 0 or 50 in the G point total box 0 G Point Total
- H. Is there a written policy regarding continuing education and training for wastewater treatment plant employees? Check one box yes no

Explain:

REQUIREMENTS: FOR EACH TWO YEAR PERIOD, MUST COMPLETE 16 HOURS OF WASTEWATER TRAINING.

- I. What percentage of the continuing education expenses of the operator-in-charge were paid for:
By the permittee? 100%
By the operator? 0%
- J. Add together the E and G point values and place this sum in the box below at the right:

TOTAL POINT VALUE FOR PART 7 0 (max=100)

Also enter this value on the point calculation table on page 16.

PART 8: FINANCIAL STATUS

- A. Are User-Charge Revenues sufficient to cover operation and maintenance expenses?
 ✓ Check one box Yes No If no, how are O & M costs being financed?

Explain:

SAME AS B.

- B. What financial resources do you have available to pay for your wastewater improvements and reconstruction needs?

WASTEWATER IMPROVEMENTS AND RECONSTRUCTION NEEDS ARE FUNDED FROM FOUR MAIN REVENUE SOURCES. THEY ARE A ONE HALF PERCENT SALES & USE TAX, SEWER USER FEES, SEWER IMPACT FEES, AND A \$4 MILLION SUBSIDY FROM THE GENERAL FUND SUPPORTED FROM GAMING REVENUES.

PART 9: SUBJECTIVE EVALUATION

A. Collection System Maintenance

1. Describe what sewer system maintenance work has been done in the last year.

SEE ATTACHMENT

2. Describe what lift station work has been done in the last year.

ROUTINE MAINTENANCE

3. What collection system improvements does the community have under consideration for the next 5 years?

SEE ATTACHMENT

B. If you have ponds, please answer the following questions:

- | | |
|---|--|
| 1. Do you have duckweed buildup in your ponds? | <input type="checkbox"/> Yes <input type="checkbox"/> No |
| 2. Do you mow your dikes regularly (at least monthly), to the waters edge? | <input type="checkbox"/> Yes <input type="checkbox"/> No |
| 3. Do you have bushes or trees growing on the dikes or in the ponds? | <input type="checkbox"/> Yes <input type="checkbox"/> No |
| 4. Do you have excess sludge buildup (> 1 foot) on the bottom of any of your ponds? | <input type="checkbox"/> Yes <input type="checkbox"/> No |
| 5. Do you exercise all of your valves? | <input type="checkbox"/> Yes <input type="checkbox"/> No |
| 6. Are your control manholes in good structural shape? | <input type="checkbox"/> Yes <input type="checkbox"/> No |
| 7. Do you maintain at least three feet of freeboard in all your ponds? | <input type="checkbox"/> Yes <input type="checkbox"/> No |
| 8. Do you visit your pond system, at least weekly? | <input type="checkbox"/> Yes <input type="checkbox"/> No |

LA0036412 SOUTH PLANT

LA MWPP ENVIRONMENTAL AUDIT

PART 9: SUBJECTIVE EVALUATION

A1. AS PART OF THE CONSENT DECREE, OPERATION AND MAINTENANCE OF THE SOUTH TREATMENT PLANT COLLECTION AREA IS PERFORMED AND REPORTED ON A QUARTERLY BASIS. THE FOLLOWING TABLE IS A BREAKDOWN/SUMMARY OF ACTIVITIES PERFORMED WITHIN THE SOUTH TREATMENT PLANT COLLECTION SYSTEM AREA DURING THE REPORTING PERIOD.

SOUTH TREATMENT AREA
MONITORING PERIOD (6/04 – 5/05)

LINE CLEANING	10%
CCTV INSPECTIONS	5%
SMOKE TESTING	4%
DYE TESTING	3%
MANHOLE INSPECTION	1%
LINE REPAIRED	5%
MANHOLE REHABILITATION	1%
FORCEMAIN-INSPECTIONS	31%
REPAIRED	10%
AIR RELEASE VALVES-INSPECTIONS	87%
REPAIRED	26%
WET WELL CLEANED	68%
PUMP STATIONS-REPAIRED	11%

A3. DURING THE NEXT 5 YEARS APPROXIMATELY 34 PROJECTS IN THE SOUTH TREATMENT PLANT COLLECTION AREA (RELATED TO THE SSO CONSENT DECREE PROGRAM) ARE SCHEDULED TO BE IMPLEMENTED, EITHER DESIGN OR BEGIN CONSTRUCTION. THE PROJECTS WILL INCLUDE PUMP STATION UPGRADES, FORCE MAIN IMPROVEMENTS, GRAVITY SEWERS, STORAGE AND WET WEATHER TREATMENT FACILITIES. ADDITIONALLY, ANNUAL CONTRACTS FOR SEWER REHABILITATION INCLUDING LINING, POINT REPAIR, UPSIZING, AND OTHER REHABILITATION METHODS WILL ALSO BE IMPLEMENTED. FOLLOWING OF A LISTING OF THE CURRENTLY PROPOSED PROJECTS.

Future South Wastewater Treatment Plant Collection System Improvements

Description
Kleinpeter Area Upgrades
SWWTP Tunnel Pump Station
South Service Area Trunk Tunnels 1
South Choctaw Area Upgrades
Magnolia Point Area Upgrades
BFU for SWWTP
Bluebonnet / Airline Extension Tunnels
Pump Station 50 Area Upgrades
Pump Station 58 Area Upgrades #1
Airline Extension Tunnels
Pump Station 327 & Pump Station 253 Area Upgrades
Pump Station 944 Area Upgrades
Gardere/GSRI Area Upgrades
South Seigen Area Upgrades
Pump Station 40 & Pump Station 57 Area Upgrades
Old Hammond Tunnels
Pump Station 31 Area Upgrades
Pump Station 177 Area Upgrades
Pump Station 170 & 274 Area Upgrades
Hoo Shoo Too and Jefferson Highway Area Upgrades
Pump Station 53 Area Upgrades #1
Pump Station 53 Area Upgrades #2
Pump Station 236 Area Upgrades
Pump Station 58 Area Upgrades #2
Pump Station 66 Area Upgrades
Tiger Bend / Antioch Area Upgrades
Pump Station 101 & Pump Station 21 Area Upgrades
Booster Pump Station 100 Area Upgrades
Booster Pump Station 508 Area Upgrades
SWWTP Upgrades
Industriplex Area Upgrades
Pump Station 211 Area Upgrades
Pump Station 136 Area Upgrades
Future South Investigations

C. Treatment Plants

1. Have the influent and effluent flow meters been calibrated in the last year? Yes No

Influent flow meter calibration date(s):

Effluent flow meter calibration date(s):

11/8/04	* North Chamber - see below * South Chamber - see below
---------	--

2. What problems, if any, have been experienced over the last year that have threatened treatment?

- | |
|--|
| <ol style="list-style-type: none"> 1. TRICKLING FILTERS #1 - #4, DRIVES & ROTARY DISTRIBUTORS FAILURE 2. PRIMARY BASINS #1, #2, & #6, DRIVE UNIT FAILURE 3. BAR SCREEN E-101, 102, #103, MECHANICAL FAILURE |
|--|

3. Is your community presently involved in formal planning for treatment facility upgrading?

Yes No If yes, describe:

--

* North Chamber 11/08/04
01/12/05
01/21/05

* South Chamber 12/07/04
01/11/05
01/20/05

D. Preventive Maintenance

1. Does your plant have a written plan for preventive maintenance on major equipment items?

Yes No If yes, describe:

Weekly, monthly and semi-annually preventive maintenance sheets that reflect type and frequency as specified in the O & M manuals. A new computer program will manage the maintenance and preventive maintenance of plant equipment and spare parts.

2. Does this preventive maintenance program depict frequency of intervals, types of lubrication, and other preventive maintenance tasks necessary for each piece of equipment? Yes No

3. Are these preventive maintenance tasks, as well as equipment problems, being recorded and filed so future maintenance problems can be assessed properly? Yes No

E. Sewer Use Ordinance

1. Does your community have a sewer use ordinance that limits or prohibits the discharge of excessive conventional pollutants (BOD, TSS, or pH) or toxic substances to the sewer from industries, commercial users, and residences?

Yes No If yes, describe:

Sewer User Fee Ordinance (No. 7853) limits the discharge of BOD & TSS to 200 mg/l and 250 mg/l respectively. Any discharge above these limits is surcharged at a rate of 2% of the monthly sewer user fee for each limit of 10 mg/l. Pretreatment Ordinance (No. 9195) limits the discharge of heavy metals, chemicals and toxic substances.

2. Has it been necessary to enforce? Yes No If yes, describe:

The Sewer User Fee Ordinance is strictly enforced by City-Parish and self monitoring sampling. The same apply to the Pretreatment Ordinance. Enforcement mechanisms include discharge permits, surcharges, letter and notice of violations, administrative orders, water termination and fines.

F. Any additional comments about your treatment plant or collection system? (Attach additional sheet if necessary.)

NO

Facility Name

LA0036412 SOUTH PLANT

POINT CALCULATION TABLE

Fill in the values from parts 1 through 7 in the columns below. Add the numbers in the left column to determine the point total that the wastewater system has generated for the previous year.

Actual Values	Actual Values	Maximum
Part 1: Influent Flow/Loadings	<u>0</u>	80 Points
Part 2: Effluent Quality/Plant Performance	<u>100</u>	100 Points
Part 3: Age of WWTT	<u>17.5</u>	50 Points
Part 4: Overflows and Bypasses	<u>100</u>	100 Points
Part 5: Ultimate Disposition of Sludge	<u>10</u>	100 Points
Part 6: New Development	<u>0</u>	30 Points
Part 7: Operator Certification Training	<u>0</u>	100 Points

TOTAL POINTS

227.5

ATTACHMENT 3

SAMPLE MWPP RESOLUTION

Resolved that the city/town of BATON ROUGE informs Louisiana Department of Environmental Quality that the following actions were taken by the CITY/PARISH METROPOLITAN COUNCIL (governing body).

1. Reviewed the Municipal Water Pollution Prevention Environmental Audit Report which is attached to this resolution.
2. Set forth the following actions necessary to maintain permit requirements contained in the Louisiana Water Discharge Permit System (LWDPS) number LA0036412.

(Please be specific in listing the actions that will be taken to address the problems identified in the audit report.)

- a. CURRENTLY, WE ARE OPERATING UNDER A CONSENT DECREE WHICH BECAME EFFECTIVE MARCH 14, 2002.
- b. IMPLEMENTATION OF AGGRESSIVE PROCESS CONTROL STRATEGIES RECOMMENDED BY LOUISIANA STATE UNIVERSITY CIVIL & ENVIRONMENTAL ENGINEERING DEPARTMENT.
- c. A PROJECT IS UNDERWAY TO REDUCE THE HIGH CONCENTRATION OF HYDROGEN SULFIDE (H₂S).

d.

etc.

Passed by a majority unanimous (circle one) vote of the CITY/PARISH METROPOLITAN COUNCIL, on August 24, 2005 (date).

ADOPTED
METROPOLITAN COUNCIL

AUG 24 2005

996

RESOLUTION 44331

Brian Mayne
COUNCIL ADMINISTRATOR TREASURER

REQUESTING APPROVAL FOR SUBMITTAL OF THE LOUISIANA MUNICIPAL WATER POLLUTION PREVENTION (MWPP) ENVIRONMENTAL AUDIT REPORT FOR THE SOUTH WASTEWATER TREATMENT PLANT TO THE DEPARTMENT OF ENVIRONMENTAL QUALITY (DEQ) FOR THE MONITORING PERIOD OF JUNE 1, 2004 THROUGH MAY 31, 2005.

BE IT RESOLVED by the Metropolitan Council of the Parish of East Baton Rouge and City of Baton Rouge that the submittal of the Louisiana Municipal Water Pollution Prevention (MWPP) Environmental Audit Report for the South Wastewater Treatment Plant to the Department of Environmental Quality (DEQ) for the monitoring period of June 1, 2004 through May 31, 2005, is hereby approved.

CERTIFIED
A TRUE COPY

SEP 06 2005

Casey Cash
Assistant Council Administrator



LEGEND
 A TEMPORARY MONUMENT ELEV. 52.27 WEST SIDE OF S.A.A.
 FOR TRENCH FILTER NO. 2



- SHOWN IN EXISTING AND PROJ.
- NEW EXISTING
- ⊕ NEW EXISTING
- ⊕ NEW EXISTING

GENERAL NOTES

1. LOCATION, ELEVATIONS, AND DIMENSIONS OF EXISTING UTILITIES, STRUCTURES AND OTHER FEATURES ARE SHOWN ACCORDING TO THE BEST AVAILABLE INFORMATION. THE CONTRACTOR SHALL VERIFY AND BE FULLY RESPONSIBLE FOR THE ACCURACY OF ALL DIMENSIONS AND CONDITIONS OF THE EXISTING AND SHALL NOT CONSTITUTE AN EXTRA UNLESS APPROVED BY THE ENGINEER.
2. THE CONTRACTOR SHALL CONTACT THE ENGINEER'S OFFICE IMMEDIATELY CONCERNING ANY CONTACTS AROUND EXISTING UTILITIES OR STRUCTURES THAT MAY BE REQUIRED OR DISTURBED DURING CONSTRUCTION AT NO ADDITIONAL COST TO THE OWNER.
3. THE CONTRACTOR SHALL USE ALL PERMANENT STABLE ZONE DATA, CURVES, AND OTHER INFORMATION TO DETERMINE THE EXACT LOCATION OF ALL UTILITIES AND STRUCTURES THAT MAY BE REQUIRED OR DISTURBED DURING CONSTRUCTION AT NO ADDITIONAL COST TO THE OWNER.
4. ALL PROTECTIVE DEVICES ARE DESIGNED FOR THE PROTECTION OF EXISTING UTILITIES AND STRUCTURES. THE CONTRACTOR SHALL VERIFY AND BE FULLY RESPONSIBLE FOR THE ACCURACY OF ALL DIMENSIONS AND CONDITIONS OF THE EXISTING AND SHALL NOT CONSTITUTE AN EXTRA UNLESS APPROVED BY THE ENGINEER.
5. PROTECTIVE DEVICES ARE DESIGNED FOR THE PROTECTION OF EXISTING UTILITIES AND STRUCTURES. THE CONTRACTOR SHALL VERIFY AND BE FULLY RESPONSIBLE FOR THE ACCURACY OF ALL DIMENSIONS AND CONDITIONS OF THE EXISTING AND SHALL NOT CONSTITUTE AN EXTRA UNLESS APPROVED BY THE ENGINEER.
6. PROTECTIVE DEVICES ARE DESIGNED FOR THE PROTECTION OF EXISTING UTILITIES AND STRUCTURES. THE CONTRACTOR SHALL VERIFY AND BE FULLY RESPONSIBLE FOR THE ACCURACY OF ALL DIMENSIONS AND CONDITIONS OF THE EXISTING AND SHALL NOT CONSTITUTE AN EXTRA UNLESS APPROVED BY THE ENGINEER.
7. PROTECTIVE DEVICES ARE DESIGNED FOR THE PROTECTION OF EXISTING UTILITIES AND STRUCTURES. THE CONTRACTOR SHALL VERIFY AND BE FULLY RESPONSIBLE FOR THE ACCURACY OF ALL DIMENSIONS AND CONDITIONS OF THE EXISTING AND SHALL NOT CONSTITUTE AN EXTRA UNLESS APPROVED BY THE ENGINEER.
8. PROTECTIVE DEVICES ARE DESIGNED FOR THE PROTECTION OF EXISTING UTILITIES AND STRUCTURES. THE CONTRACTOR SHALL VERIFY AND BE FULLY RESPONSIBLE FOR THE ACCURACY OF ALL DIMENSIONS AND CONDITIONS OF THE EXISTING AND SHALL NOT CONSTITUTE AN EXTRA UNLESS APPROVED BY THE ENGINEER.
9. PROTECTIVE DEVICES ARE DESIGNED FOR THE PROTECTION OF EXISTING UTILITIES AND STRUCTURES. THE CONTRACTOR SHALL VERIFY AND BE FULLY RESPONSIBLE FOR THE ACCURACY OF ALL DIMENSIONS AND CONDITIONS OF THE EXISTING AND SHALL NOT CONSTITUTE AN EXTRA UNLESS APPROVED BY THE ENGINEER.
10. PROTECTIVE DEVICES ARE DESIGNED FOR THE PROTECTION OF EXISTING UTILITIES AND STRUCTURES. THE CONTRACTOR SHALL VERIFY AND BE FULLY RESPONSIBLE FOR THE ACCURACY OF ALL DIMENSIONS AND CONDITIONS OF THE EXISTING AND SHALL NOT CONSTITUTE AN EXTRA UNLESS APPROVED BY THE ENGINEER.
11. PROTECTIVE DEVICES ARE DESIGNED FOR THE PROTECTION OF EXISTING UTILITIES AND STRUCTURES. THE CONTRACTOR SHALL VERIFY AND BE FULLY RESPONSIBLE FOR THE ACCURACY OF ALL DIMENSIONS AND CONDITIONS OF THE EXISTING AND SHALL NOT CONSTITUTE AN EXTRA UNLESS APPROVED BY THE ENGINEER.
12. PROTECTIVE DEVICES ARE DESIGNED FOR THE PROTECTION OF EXISTING UTILITIES AND STRUCTURES. THE CONTRACTOR SHALL VERIFY AND BE FULLY RESPONSIBLE FOR THE ACCURACY OF ALL DIMENSIONS AND CONDITIONS OF THE EXISTING AND SHALL NOT CONSTITUTE AN EXTRA UNLESS APPROVED BY THE ENGINEER.
13. PROTECTIVE DEVICES ARE DESIGNED FOR THE PROTECTION OF EXISTING UTILITIES AND STRUCTURES. THE CONTRACTOR SHALL VERIFY AND BE FULLY RESPONSIBLE FOR THE ACCURACY OF ALL DIMENSIONS AND CONDITIONS OF THE EXISTING AND SHALL NOT CONSTITUTE AN EXTRA UNLESS APPROVED BY THE ENGINEER.
14. PROTECTIVE DEVICES ARE DESIGNED FOR THE PROTECTION OF EXISTING UTILITIES AND STRUCTURES. THE CONTRACTOR SHALL VERIFY AND BE FULLY RESPONSIBLE FOR THE ACCURACY OF ALL DIMENSIONS AND CONDITIONS OF THE EXISTING AND SHALL NOT CONSTITUTE AN EXTRA UNLESS APPROVED BY THE ENGINEER.
15. PROTECTIVE DEVICES ARE DESIGNED FOR THE PROTECTION OF EXISTING UTILITIES AND STRUCTURES. THE CONTRACTOR SHALL VERIFY AND BE FULLY RESPONSIBLE FOR THE ACCURACY OF ALL DIMENSIONS AND CONDITIONS OF THE EXISTING AND SHALL NOT CONSTITUTE AN EXTRA UNLESS APPROVED BY THE ENGINEER.
16. PROTECTIVE DEVICES ARE DESIGNED FOR THE PROTECTION OF EXISTING UTILITIES AND STRUCTURES. THE CONTRACTOR SHALL VERIFY AND BE FULLY RESPONSIBLE FOR THE ACCURACY OF ALL DIMENSIONS AND CONDITIONS OF THE EXISTING AND SHALL NOT CONSTITUTE AN EXTRA UNLESS APPROVED BY THE ENGINEER.
17. PROTECTIVE DEVICES ARE DESIGNED FOR THE PROTECTION OF EXISTING UTILITIES AND STRUCTURES. THE CONTRACTOR SHALL VERIFY AND BE FULLY RESPONSIBLE FOR THE ACCURACY OF ALL DIMENSIONS AND CONDITIONS OF THE EXISTING AND SHALL NOT CONSTITUTE AN EXTRA UNLESS APPROVED BY THE ENGINEER.
18. PROTECTIVE DEVICES ARE DESIGNED FOR THE PROTECTION OF EXISTING UTILITIES AND STRUCTURES. THE CONTRACTOR SHALL VERIFY AND BE FULLY RESPONSIBLE FOR THE ACCURACY OF ALL DIMENSIONS AND CONDITIONS OF THE EXISTING AND SHALL NOT CONSTITUTE AN EXTRA UNLESS APPROVED BY THE ENGINEER.
19. PROTECTIVE DEVICES ARE DESIGNED FOR THE PROTECTION OF EXISTING UTILITIES AND STRUCTURES. THE CONTRACTOR SHALL VERIFY AND BE FULLY RESPONSIBLE FOR THE ACCURACY OF ALL DIMENSIONS AND CONDITIONS OF THE EXISTING AND SHALL NOT CONSTITUTE AN EXTRA UNLESS APPROVED BY THE ENGINEER.
20. PROTECTIVE DEVICES ARE DESIGNED FOR THE PROTECTION OF EXISTING UTILITIES AND STRUCTURES. THE CONTRACTOR SHALL VERIFY AND BE FULLY RESPONSIBLE FOR THE ACCURACY OF ALL DIMENSIONS AND CONDITIONS OF THE EXISTING AND SHALL NOT CONSTITUTE AN EXTRA UNLESS APPROVED BY THE ENGINEER.

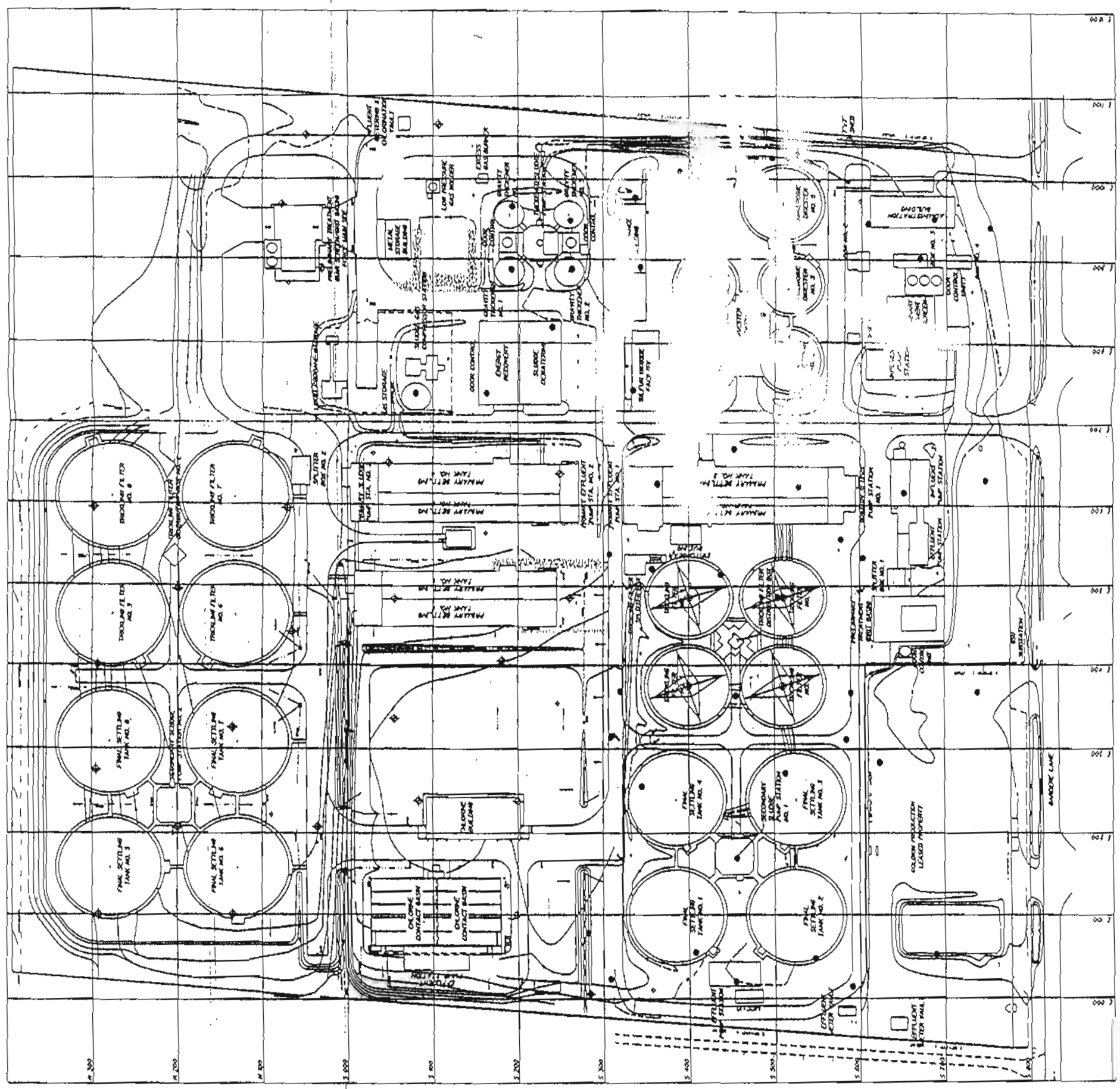

Appendix C

CITY OF BATON ROUGE
PARISH OF EAST BATON ROUGE
WASTEWATER TREATMENT & DISPOSAL DIVISION

PART 2

SPECIAL PROVISIONS
AND
CONTRACT DOCUMENTS

FOR

SCREENINGS CONVEYANCE
South Wastewater Treatment Plant
PROJECT NO.: STP-05-02

Car B. Wall
STP-05
S-3-05

THIS PROPOSAL WILL BE RECEIVED BY THE PURCHASING DIVISION,
CITY OF BATON ROUGE AND PARISH OF EAST BATON ROUGE ROOM 309,
MUNICIPAL BUILDING 300 NORTH BOULEVARD, BATON ROUGE, LA 70801 UNTIL

2:00 P.M., TUESDAY, FEBRUARY 22, 2005

A **Mandatory Pre-bid Conference** Will Be Held on FEBRUARY 9, 2005 AT 9:00 A.M.
At The South Wastewater Treatment Plant, 2850 Gardere Lane, Baton Rouge, La.
Only Bidders who attend the Pre-Bid Conference will be eligible to submit bids.

For Additional Information, Contact Mr. Richard Wright at (225) 389-3154.

INSTRUCTIONS TO BIDDERS

- 1. Submit Part 1, Bid Forms only as your bid.*
- 2. Retain Part 2, Special Provisions and Contract Documents for your records*

**CITY OF BATON ROUGE
PARISH OF EAST BATON ROUGE**

February 15, 2005

ADDENDUM NO. 1

TO: ALL BIDDERS

SUBJECT: Screenings Conveyance, South Wastewater Treatment Plant
CONTRACT NUMBER STP-05-02

The following revisions shall be incorporated in and take precedence over any conflicting part of the original Special Provisions and Contract Documents.

Part 1 – Bid Forms

1. With reference to page CP-1 of the Construction Proposal, the Bidder shall indicate the receipt of this addendum in the space provided (See Line Item No. 8). Failure to indicate receipt of this addendum shall be cause for the bid to be rejected.
2. The bid date and time for this project are hereby changed to 2:00 p.m. on March 1, 2005.

Part 2 – Special Provisions and Contract Documents

1. In the Special Provisions, under Section 9, add the following:

“9-7, TEMPORARY SUSPENSION OF WORK – This Subsection of the Standard Specifications is amended as follows:

In order to reduce air pollution, the contractor shall suspend all operations on this project, except those operations necessary to protect against the loss or damage to life property, on days that the Louisiana Department of Environmental Quality (LaDEQ) forecasts will be “Ozone Alert” days. The order to suspend operations of the project will be in writing and will be sent to the contractor as soon as possible the day before the forecasted “Ozone Alert” day. The contractor shall resume operations on the project the following day, unless the LaDEQ forecasts the day will also be an “Ozone Alert” day whereupon the contractor will be issued another 1-day suspension order in writing.

The contractor will be granted a 1 calendar day extension of contract time; however, the City-Parish will not be liable for any additional costs incurred by the contractor due to an “Ozone Alert” suspension order.”

2. In the Technical Specifications, Page TS-1, Section 1.2, revise item B as follows:

- “B. The new screw conveyance system shall receive screenings from each of the four existing units. Each unit shall be equipped with drop chutes to direct screenings to the new system. The new system shall be designed to handle wash water from the existing screens, which is generated at a rate of approximately 150 gpm.”
3. In the Technical Specifications, Sections 2.1.A, 2.1.C, 2.2.D and 2.5.A, replace all references to 316 stainless steel with 304 stainless steel.
 4. In the Technical Specifications, Page TS-3, Section 2.1.A, revise item 3 as follows:

“3. A minimum 4” diameter Schedule 80 PVC drain pipe shall be furnished and installed by the CONTRACTOR to direct drained liquid back to the screen channel.”
 5. In the Technical Specifications, Page TS-3, Section 2.1.D, revise item 1 as follows:

“1. The drive unit shall be a hollow shaft mounted gear motor rated at a minimum AGMA Class II, single or double reduction or triple reduction. A 7.5-HP 230/460/3/60 TEFC constant speed drive shall be provided. Reducers shall be provided to run the conveyor at approximately 20 RPM.”
 6. In the Technical Specifications, Page TS-4, Section 2.2.C, revise item 2 as follows:

“2. Wash module piping shall be 304 stainless steel.”
 7. In the Technical Specifications, Page TS-4, Section 2.2.C, add the following item:

“3. Plumbing to the wash module shall be installed by the CONTRACTOR.”
 8. In the Technical Specifications, Page TS-4, Section 2.2.E, revise item 3 as follows:

“3. The drive unit shall be a hollow shaft mounted gear motor rated at a minimum AGMA Class II, single or double reduction or triple reduction. A minimum 1.5-HP 230/460/3/60 TEFC 230/460, 60-hz 3-phase constant speed drive shall be provided, running at approximately 20 RPM.
 9. In the Technical Specifications, Page TS-5, Section 2.3, revise item 1.1 as follows:

“1. 3 position F-O-R selector switches for each unit. The reverse position of the F-O-R switches shall be spring loaded with manual hold activation.”
 10. In the Technical Specifications, Page TS-5, Section 2.4, revise Part A as follows:

“A. The conveyor equipment shall be manufactured by one of the following:

 1. U.S. Filter Link-Belt Products.

2. Parkson Corporation.
3. Bulk Conveyor Specialist, Inc.
4. Approved Equal."

11. In the Technical Specifications, Page TS-5, Section 2.5.A, revise item 4 as follows:

"4. Drain piping shall be furnished and installed by the CONTRACTOR to rout excess water from the conveyors back into the plant headworks/bar screen channels. Piping size shall be as recommended by the equipment manufacturer, but shall not be less than 4". Pipe shall be Schedule 80 PVC."

12. In the Technical Specifications, Page TS-5, Section 2.5.A, revise item 5 as follows:

"5. Discharge chutes shall be furnished and installed to connect the outlets of the bar screens with the inlets to the horizontal conveyor.

- a. Neoprene chutes (18" W x 58" L) for Bar Screen No. 1, 2 and 3 have been provided by the manufacturer and are available for the CONTRACTOR's use. Clearance from the slab to the chute bottom is approximately 57".
- b. A discharge chute/connection for Bar Screen No. 4 shall be furnished and installed by the CONTRACTOR. The discharge chute shall be 304 stainless steel."

13. In the Technical Specifications, Page TS-6, Section 2.5.B, revise item 3 as follows:

"3. The new screw conveyor control panel shall be installed on the north wall of the Bar Screens building in the area of the removed belt conveyor junction box. The Bar Screens building is a Hazardous (Classified) Location as defined by NEC."

14. In the Technical Specifications, Page TS-6, Section 2.5.B, add the following item:

"10. The new conveyor support structure shall be grounded. The CONTRACTOR shall extend the existing ground cable and securely connect it to the conveyor structure using proper grounding fittings."

15. In the Technical Specifications, Page TS-6, Section 2.5, add the following item:

"E. Continuity of Operation

1. Bar screens may be out of service for a maximum of 24 hours for conveyor installation."

16. In the Technical Specifications, replace Figures 2, 3 and 4 with the attached Figures.

Approved for Distribution:

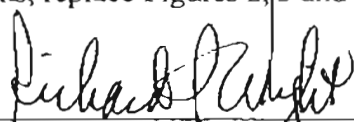
Richard Wright, PE

THE ADVOCATE
BATON ROUGE, LOUISIANA

CITY OF BATON ROUGE AND PARISH OF EAST BATON ROUGE

NOTICE TO CONTRACTORS

The City of Baton Rouge and Parish of East Baton Rouge hereby advertise for Bids for construction of wastewater facilities for the East Baton Rouge Sewerage Commission as follows:

Contract Name: Screenings Conveyance
 South Wastewater Treatment Plant
Contract No.: STP-05-02

The Contract Work consists of furnishing all labor, materials, equipment and incidentals to remove and replace existing screenings conveyance units downstream of existing bar screens at the City/Parish's South Wastewater Treatment Plant.

Sealed Bids must be received by the Purchasing Agent, City of Baton Rouge and Parish of East Baton Rouge, Room 309, Municipal Building, 300 North Boulevard, Baton Rouge, Louisiana, either by mail or hand delivery, no later than **2:00 P.M.**, local time, **Tuesday, February 22, 2005**. Promptly thereafter, Bids will be publicly opened and read aloud in Room 415 of the Municipal Building.

The Bidding Documents (Special Provisions, Contract Documents, and Drawings) are on file and may be obtained by Contractors who are properly licensed in Louisiana in the Municipal and Public Works Construction classification or by bona fide suppliers of materials and equipment, from the City-Parish Department of Public Works (DPW), Sewer Operations – General Administration Division, Room 200, 329 Chippewa Street, 2nd Floor, Baton Rouge, Louisiana.

A certified check or cashier's check, payable to the Parish of East Baton Rouge, or a satisfactory Bid Bond executed by the Bidder and an acceptable Surety, in an amount equal to five percent (5%) of the total, shall be submitted with each Bid.

A **Mandatory Pre-Bid Conference** to discuss the scope of the project and requirements of the Bidding and Contract Documents will be held at **9:00 A.M., February 9, 2005**, at The South Wastewater Treatment Plant, 2850 Gardere Lane, Baton Rouge, La. 70820.

For any additional information contact Sewer Operations General Administration at (225) 389-3154.

**CITY OF BATON ROUGE
PARISH OF EAST BATON ROUGE**

PROPOSAL

PROJECT NAME: Screenings Conveyance
South Wastewater Treatment Plant
PROJECT No.: STP-05-02

Proposals will be received up to 2:00 P.M., Local Time, Tuesday, February 22, 2005 by the Purchasing Division, Room 309, 300 North Boulevard, Municipal Building, Baton Rouge, Louisiana 70801. Bids will be publicly opened and read aloud in Room 415 of the Municipal Building immediately thereafter.

BID OF: R.L. MIXON CONTRACTORS, INC.

ADDRESS: PO BOX 14086, BATON ROUGE, LA. 70898

DATE: 3/1/2005

**Director of Purchasing
City of Baton Rouge
Parish of East Baton Rouge
Baton Rouge, Louisiana**

I (We) hereby agree to furnish all materials, tools, equipment, labor, and insurance to perform the work required for the following project:

PROJECT NAME: Screenings Conveyance
South Wastewater Treatment Plant
PROJECT No.: STP-05-02

as set forth in the following documents:

1. Notice to Contractors
2. Proposal
3. Special Provisions
4. The Standard Specifications
5. Technical Specifications
6. Agreement
7. Figures 1 through 4
8. The following enumerated addenda: 1 2/15/05

The undersigned, as bidder, declares that the only persons or parties interested in this proposal as principals are those named herein; that this proposal is made without collusion or combination of any kind or character with any other person, firm, association or corporation, or any member or official thereof, that

he has (or they have) carefully examined the site of the proposed work, the plans, Standard Specifications and Special Provisions above mentioned, and the form of contract and contract bond; that he (or they) proposes, and agrees, if this proposal is accepted to provide all necessary machinery, tools, apparatus, and other means of construction and will do all the work and furnish all the materials specified in the contract, in the manner and time therein prescribed and in accordance with the requirements of the Engineer as therein set forth; and that he (or they) hereby proposes to accept as full compensation therefore the total amount herein bid, subject to any mutually agreed upon change orders.

The undersigned proposes to perform all extra and force account work that may be required on the basis provided in the specifications, to give such work his personal attention and to secure economical performance.

The undersigned further agrees that the proposal is firm for a period of sixty (60) days from the opening of bids and no proposal can be withdrawn for any reason during this period of time.

The undersigned further agrees that within fifteen (15) days after notice that the Parish has been authorized to enter into a contract he will execute the Agreement and furnish to the Parish of East Baton Rouge all insurance certificates required by Contract.

The undersigned further agrees that the work will begin not later than fourteen (14) calendar days after the date of the Notice to Proceed and shall be diligently prosecuted at such rate and in such manner as necessary for the completion of the work within the time specified in the Agreement.

Accompanying this proposal is a certified check, cashiers check, or a bid bond which represents **Five Percent (5%)** of the amount of the bid, payable to the City of Baton Rouge. If this proposal shall be accepted and the undersigned shall fail to exercise the contract and furnish performance and payment surety bond as provided above, then the bid security shall be forfeited.

The lump sum price for completion of all work in accordance with the Contract Documents is:

TWO HUNDRED
BASE BID (WRITTEN) TWENTY SIX THOUSAND DOLLARS AND NO CENTS (IN
FIGURES) \$ 26,000.00

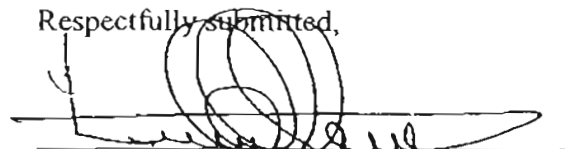
Respectfully submitted,

(Signature)

THE ATTACHED SHEET (CP 3 OF 5) MUST BE COMPLETED TO INDICATE WHETHER BIDDER IS AN INDIVIDUAL, UNINCORPORATED FIRM OR A CORPORATION.

THE ATTACHED BID BOND SHEET (CP 5 OF 5), OR SIMILAR BID BOND, MUST BE COMPLETED IF A BID BOND, IN LIEU OF A CERTIFIED CHECK OR CASHIERS CHECK, ACCOMPANIES THIS BID.

**BIDDER'S ORGANIZATION
BIDDER IS:**

AN INDIVIDUAL

Individual's Name: _____

Doing business as: _____

Address: _____

Telephone No.: _____ Fax No.: _____

A PARTNERSHIP

Firm Name: _____

Address: _____

Name of person authorized to sign: _____

Title: _____

Telephone No.: _____ Fax No.: _____

A LIMITED LIABILITY COMPANY

Company Name: _____

Address: _____

Name of person authorized to sign: _____

Title: _____

Telephone No.: _____ Fax No.: _____

A CORPORATION

IF BID IS BY A CORPORATION, THE CORPORATE RESOLUTION MUST BE SUBMITTED WITH BID.

Corporation Name: R.L. MIXON CONTRACTORS, INC.

Address: 5940 C PERKINS ROAD, BATON ROUGE, LA 70808

State of Incorporation: LOUISIANA

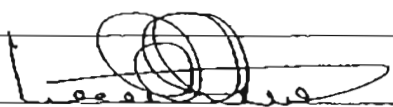
Name of person authorized to sign: LINK E. MIXON 

Title: PRESIDENT

Telephone No.: 225-766-2594 Fax No.: 225-766-2698

IF BID IS BY A JOINT VENTURE, ALL PARTIES TO THE BID MUST COMPLETE THIS FORM.

POWER OF ATTORNEY

Direct Inquiries/Claims to:

THE HARTFORD
BOND, T-4
690 ASYLUM AVENUE
HARTFORD, CONNECTICUT 06115
call: 888-266-3488 or fax: 860-757-5835

KNOW ALL PERSONS BY THESE PRESENTS THAT:

Agency Code: 43-482992

- Hartford Fire Insurance Company, a corporation duly organized under the laws of the State of Connecticut
- Hartford Casualty Insurance Company, a corporation duly organized under the laws of the State of Indiana
- Hartford Accident and Indemnity Company, a corporation duly organized under the laws of the State of Connecticut
- Hartford Underwriters Insurance Company, a corporation duly organized under the laws of the State of Connecticut
- Twin City Fire Insurance Company, a corporation duly organized under the laws of the State of Indiana
- Hartford Insurance Company of Illinois, a corporation duly organized under the laws of the State of Illinois
- Hartford Insurance Company of the Midwest, a corporation duly organized under the laws of the State of Indiana
- Hartford Insurance Company of the Southeast, a corporation duly organized under the laws of the State of Florida

having their home office in Hartford, Connecticut, (hereinafter collectively referred to as the "Companies") do hereby make, constitute and appoint, up to the amount of unlimited:

J. Dale Gault, Charles E. Riddle, Brenda Ann Riddle, Henry Luckett Marye, Jr., T. Dwight Verges, David W. Alligood
of
Baton Rouge, LA

their true and lawful Attorney(s)-in-Fact, each in their separate capacity if more than one is named above, to sign its name as surety(ies) only as delineated above by , and to execute, seal and acknowledge any and all bonds, undertakings, contracts and other written instruments in the nature thereof, on behalf of the Companies in their business of guaranteeing the fidelity of persons, guaranteeing the performance of contracts and executing or guaranteeing bonds and undertakings required or permitted in any actions or proceedings allowed by law.

In Witness Whereof, and as authorized by a Resolution of the Board of Directors of the Companies on July 21, 2003 the Companies have caused these presents to be signed by its Assistant Vice President and its corporate seals to be hereto affixed, duly attested by its Assistant Secretary. Further, pursuant to Resolution of the Board of Directors of the Companies, the Companies hereby unambiguously affirm that they are and will be bound by any mechanically applied signatures applied to this Power of Attorney



Paul A. Bergenholz

Paul A. Bergenholz, Assistant Secretary

David T Akers

David T Akers, Assistant Vice President

STATE OF CONNECTICUT }
COUNTY OF HARTFORD } ss. Hartford

On this 23rd day of July, 2003, before me personally came David T. Akers, to me known, who being by me duly sworn, did depose and say: that he resides in the County of Hampden, Commonwealth of Massachusetts; that he is the Assistant Vice President of the Companies, the corporations described in and which executed the above instrument; that he knows the seals of the said corporations; that the seals affixed to the said instrument are such corporate seals; that they were so affixed by authority of the Boards of Directors of said corporations and that he signed his name thereto by like authority.



CERTIFICATE

Scott E. Paseka

Scott E. Paseka
Notary Public

My Commission Expires October 31, 2007

I, the undersigned, Assistant Vice President of the Companies, DO HEREBY CERTIFY that the above and foregoing is a true and correct copy of the Power of Attorney executed by said Companies, which is still in full force effective as of

Signed and sealed at the City of Hartford.



Gary W. Stumper

Gary W. Stumper, Assistant Vice President

AGREEMENT

THIS AGREEMENT made and entered into at Baton Rouge, Louisiana, effective this 4th day of April, 2005 by and between the East Baton Rouge Sewerage Commission, an agency and instrumentality of the City of Baton Rouge/Parish East Baton Rouge, hereinafter called "OWNER" and, R. L. Mixon Contractors, Inc., hereinafter called "CONTRACTOR".

The Contractor shall perform all work required by the Contract Documents for Screenings Conveyance, South Wastewater Treatment Plant, Project No. STP-05-02.

The following Contract Documents are all hereby made a part of this Agreement to the same extent as if incorporated herein in full:

1. Notice to Contractors
2. Proposal
3. Special Provisions
4. The Standard Specifications
5. Technical Specifications
6. Figures 1 through 4
7. Agreement
8. The following enumerated addenda: #1 2/15/05

CONTRACT TIME

The entire contract shall be completed in all details and ready for final acceptance within 180 calendar days after date stipulated in the Notice to Proceed. Time is of the essence of the contract and the Notice to Proceed will be issued promptly. Contract time extensions will only be allowed in accordance with provisions in the Contract Documents.

FAILURE TO COMPLETE WORK ON TIME

Should the Contractor fail to complete the work within the contract time, as extended, liquidated damages in the amount of Two Hundred Seventy Dollars (\$270.00) per day, will be assessed to the Contractor in accordance with the Contract Documents.

INTERPRETATIONS OF CONTRACT PROVISIONS

The interpretations of the provisions of this contract by the Director, Department of Public Works, shall be binding upon both parties hereto.

CONTRACT PRICE

The amount to be paid to the Contractor by the Owner for Screenings Conveyance, South Wastewater Treatment Plant, Project No. STP-05-02 is Two Hundred and Twenty Six Thousand DOLLARS and No CENTS (\$226,000.00). The contract price shown is based on the Schedule of Items included in Contractor's Construction Proposal for the project showing approximate quantities and unit prices therefor. The final contract price will be determined by the actual quantities in place at the unit prices set forth in said schedule and any other modifications or changes as mutually agreed upon in writing.

PAYMENT

The Owner will make partial or progress payments, less applicable retainage, based upon monthly estimates, which exceed \$5,000.00 on or about the 10th day of the following month in accordance with the Contract Documents.

Upon satisfactory completion and acceptance of the work, the Owner will make a final payment in accordance with provisions of the Contract Documents.

AUDITS

The Contractor shall permit the authorized representative of the City-Parish to periodically inspect and audit all data and records of the Contractor relating to his performance under this contract.

INSURANCE, INDEMNITY AND LEGAL REGULATIONS

Insurance, indemnity requirements and legal regulations shall conform to those stated in the Contract Documents.

IN WITNESS WHEREOF, the parties hereto have executed this agreement effective as of the date first written above.

EAST BATON ROUGE SEWERAGE COMMISSION

WITNESSES:

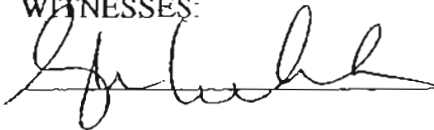
 _____

By  _____
David Boneno, President -EBROSCO

R. L. MIXON CONTRACTORS, INC.

Contractor

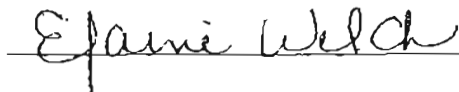
 _____

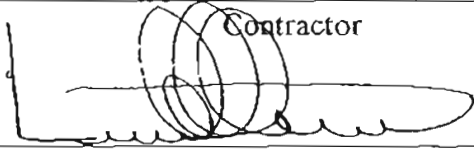
By  _____

Link E. Mixon, President

(Typed Name and Title)

APPROVED



PARISH ATTORNEY'S OFFICE

PERFORMANCE AND PAYMENT BOND

That we, the undersigned R. L. Mixon Contractors, Inc. as principal, hereinafter referred to as "Contractor" and Hartford Casualty Insurance Company, duly authorized to transact business in the State of Louisiana as surety, are held and firmly bound unto the City of Baton Rouge and Parish of East Baton Rouge, hereinafter referred to as "Owner", in the penal sum of Two Hundred and Twenty Six Thousand Dollars and No/100 (\$226,000.00) lawful money of the United States, for the payment of which well and truly to be made, the said principal and the said surety do hereby bind ourselves, our heirs, executors, administrators, and assigns, jointly and severally, by these presents as follows:

The condition of this obligation is such that whereas, the Contractor by an instrument in writing attached hereto and bearing date of April 4, 2005 has agreed with said Owner to furnish labor, materials, tools and equipment to construct Screenings Conveyance, South Wastewater Treatment Plant, PROJECT NO. STP-05-02, as shown on plans and specified thereby and in the specifications, proposals and agreement forming the contract documents thereto attached.

NOW THEREFORE, if said Contractor shall well and truly in good, sufficient and workmanship manner, and to the satisfaction of the Owner, perform and complete the work required and shall pay all costs, charges, rentals and expenses for labor, material, supplies and equipment and deliver the said improvement to the Owner complete and ready for occupancy or operation, and free from all liens, encumbrances or claims for labor, material or otherwise; and shall pay all other expenses lawfully chargeable to the Owner by reason of any default or neglect of the said Contractor in the performance of said agreement and said work, then this obligation shall be void, otherwise to remain in full force and effect.

PROVIDED FURTHER, That the said surety for value received hereby stipulates and agrees that no change, extension of time, alterations, or addition to the terms of that contract, or the work to be performed thereunder, or the specifications accompanying the same, shall in anywise affect its obligation on the bond and it does hereby waive notice of any change, extension of time, alterations, or addition to the terms of the contract, or the work, or the specifications.

PROVIDED FURTHER, That if the Contractor, or his, their, or its subcontractors fail to duly pay for any labor, materials, team hire, sustenance, provisions, provender or any other supplies or materials used or consumed or for any materials or supplies furnished for use by such contractors or his, their, or its subcontractors in performance of the work contract to be done, the Surety will pay the same in any amount not exceeding the sum specified in the bond, together with interest and attorney's fees as provided by law.

IN WITNESS WHEREOF, Said Principal and Surety have hereunto set their hands and seals this 4th day of April, 2005.

R. L. Mixon Contractors, Inc.
(Contractor)

P. O. Box 14086, Baton Rouge, LA 70898
(Address)

By: [Signature]

Hartford Casualty Insurance Company
(Surety)

Hartford Plaza, Hartford, Connecticut 06115
(Address)

By: [Signature]

David W. Alligood, Attorney-in-Fact & LA Resident Agent, LA Lic. # 302390

(Typed Name and Title)

Hibernia Insurance Agency
411 Colonial Drive
Baton Rouge, LA 70806
(225) 381-8812

[Signature]
(WITNESS)

[Signature]
(WITNESS)

SPECIAL PROVISIONS

The Standard Specifications referred to herein are the 1997 City of Baton Rouge, Parish of East Baton Rouge Standard Specifications for Public Works Construction. The Standard Specifications are hereby amended to include the following Special Provisions and where applicable shall take precedence over the aforementioned Standard Specifications. When any part of the Standard Specifications is unaltered by the following Special Provisions, the unaltered provisions of the Standard Specifications shall remain in effect.

Copies of the Standard Specifications may be obtained from the Department of Public Works, Engineering Division, Room 408, Municipal Building or Post Office Box 1471, Baton Rouge, Louisiana 70821 (Telephone No. 225-389-3186).

In PART I, GENERAL PROVISIONS, make the following modifications:

SECTION 5, CONTROL OF WORK

Add 5-15, ACCESS TO PROJECT SITE.

Unless otherwise approved by the Wastewater Treatment Plant Manager in writing, all Contractors' (his subcontractors and/or his suppliers) vehicular equipment used for the hauling of materials or equipment shall enter the work site through the main gate of each of the following locations.

**South Wastewater Treatment Plant
2850 Gardere Lane, Baton Rouge, La. 70820**

SECTION 7 LEGAL RELATIONS AND RESPONSIBILITIES TO THE PUBLIC - This Section of the Standard Specifications is amended as follows:

7-2, INSURANCE. Sub-paragraphs I through VII of the Standard Specifications are amended as follows:

CONTRACTOR'S AND SUB CONTRACTOR'S INSURANCE

Contractor and any subcontractor shall carry and maintain at least the minimum insurance as specified below until completion and acceptance of the work. Contractor shall not commence work under this contract until the certificates of insurance have been approved by the City-Parish Purchasing Division. Insurance companies listed on certificates must have industry rating of B+, Class VI, according to Best's Key Rating Guide. Contractor is responsible for assuring that its subcontractors meet these insurance requirements.

A. Commercial General Liability on an occurrence basis as follows:

General Aggregate	\$2,000,000
Products-Comp/Op Agg	\$2,000,000
Personal & Adv Injury	\$1,000,000

Each Occurrence	\$1,000,000
Fire Damage (Any one fire)	\$50,000
Med Exp	\$5,000

- B. Business Auto Policy
Any Auto, or Combined Single Limit
Owned, Non-Owned & Hired \$1,000,000
- C. Standard Workers Compensation - Full statutory liability for State of Louisiana with Employer's Liability Coverage.
- D. The City of Baton Rouge and Parish of East Baton Rouge, must be named as additional insured on all general liability policies described above.
- E. Waiver of subrogation in favor of City of Baton Rouge and Parish of East Baton Rouge, is required from Workers Compensation Insurer.
- F. Certificates must provide for thirty (30) days written notice to Certificate Holder prior to cancellation or change.
- G. The Certificate Holder should be shown as:

City of Baton Rouge and Parish of East Baton Rouge
Attn: Purchasing Division
Post Office 1471
Baton Rouge, Louisiana 70821

SECTION 9, PROSECUTION AND PROGRESS OF WORK

Work shall be performed during normal plant hours, from 7:00 A.M. to 3:00 P.M. Monday through Friday, unless the Contractor is given authorization by the plant supervisor to work outside of those hours. A written request shall be provided by the Contractor 72 hours in advance of any work to be performed on weekends, or outside of the normal plant hour stated above.

9-9, DEFAULT OF CONTRACT Add the following paragraph:

Any contractor placed in default for any of the conditions specified above shall be ineligible to bid any City-Parish work for a period of six (6) months from the date of the default, or until the reason for the default is remedied, whichever is earlier. In addition, failure to accept contract as bid after being awarded by City-Parish shall subject the contractor to six (6) months suspension from bidding any City-Parish work. In any event, the Contractor is not eligible to re-bid any project for which he has been placed in default.

TECHNICAL SPECIFICATIONS

Screenings Conveyance
South Wastewater Treatment Plant
PROJECT NO.: STP-05-02

PART I - GENERAL

1.1 Description

A. Scope

1. The CONTRACTOR shall provide all labor, materials, equipment, and incidentals required to remove existing screenings belt conveyors and furnish and install a new screw conveyance system at the City/Parish's South Wastewater Treatment Plant.
2. The Work shall include, but not be limited to, the following:
 - a. Remove and salvage existing belt conveyance system, including both the horizontal and inclined belt conveyor. Removal shall include associated supports, electrical wiring, and additional appurtenances.
 - b. Furnish and install one horizontal screw conveyor, with controls, for conveyance of screenings from existing bar screens to a new inclined screw conveyor.
 - c. Furnish and install one inclined screw conveyor/compactor, with controls, for transfer of screenings from the new horizontal conveyor to an existing screenings bin.
 - d. Remove one concrete curb from the conveyor containment area, and re-pour the curb in a new location that allows the existing screens to be fastened to the slab of the bar screen facility.
3. Details of the work are described herein and shown on the attached figures (Figure 1 through Figure 4).

B. Lump Sum Bid

1. The CONTRACTOR's bid shall be a lump sum for all work included under this contract.

1.2 Existing Facilities

- A. Existing belt conveyors collect screenings from a total of four bar screens, including three U.S. Filter Link Belt Products Thru Flo/FE Screens and one Infilco Degremont Climber Screen.
- B. The new screw conveyance system shall receive screenings from each of the four existing units. Each unit shall be equipped with drop chutes to direct screenings to the new system. Each of three screens generates spray wash water at a rate of approximately 150 gpm. The new system shall be designed to handle wash water from each screen operating simultaneously.

1.3 Quality Assurance

- A. Reference Standards: Comply with applicable provisions and recommendations of the following,

except as otherwise shown or specified.

1997 City/Parish Standard Specifications for Public Works Construction

Occupational Safety and Health (OSHA) Standards, 29 CFR 1910

B. Manufacturer Qualifications

1. The equipment specified herein shall be supplied by a manufacturer regularly engaged in the U.S. for a minimum of five years in the design and manufacturing of screenings conveyance systems for the wastewater industry.
2. The CONTRACTOR must supply a list of five verifiable installations of the type required in this specification with his shop drawings. The list shall include phone numbers, contact name, facility name and date of installation.

1.4 Submittals

A. Shop Drawings

1. Submit shop drawings for all equipment, including conveyors, control panels, supports, etc. Shop drawings shall include materials description, equipment listing, and all other pertinent data required to demonstrate compliance with these specifications.
2. Four copies of shop drawings shall be provided.
3. Allow two weeks for OWNER's review.

B. Operation and Maintenance Manuals:

1. Submit complete installation, operation and maintenance manuals for the new equipment, including copies of all approved Shop Drawings, test reports, maintenance data and schedules, description of operation, and spare parts information.
2. Four copies of this data shall be provided for OWNER's review. Once comments are provided to the CONTRACTOR by the OWNER, the CONTRACTOR shall address all comments and provide four final O&M Manuals.

1.5 Product Delivery, Storage and Handling

- A. Deliver materials to the site to insure uninterrupted progress of the Work.
- B. Store materials to permit easy access for inspection and identification. Protect steel parts and other materials from corrosion and deterioration. Storage area will be designated by OWNER.
- C. Store mechanical equipment in covered storage off the ground and prevent condensation.

PART 2- EQUIPMENT

2.1 Horizontal Screw Conveyor

A. Screw Trough and Chutes

1. The screw trough shall be of 316 stainless steel, and shall be constructed of, at a minimum, 1/8" steel. Screw hold-downs shall be complete with 3/8" x 1" wear bars the full length of the trough.
2. At a minimum, one drain box shall be provided at the low end of the conveyor. A brush on the screw shall be provided at the drain box.
3. A minimum 4" diameter PVC drain pipe shall be furnished and installed by the CONTRACTOR to direct drained liquid back to the screen channel.
4. The trough shall have a flanged discharge with transition pieces to connect the horizontal conveyor with the inclined conveyor.
5. Covers shall be, at a minimum No. 10 gauge stainless steel, flanged and furnished with hinged inspection doors.
6. Four flanged/bolted inlet hoppers approximately 4.5' wide shall be included to accept screenings discharge.

B. Shaftless Screw

1. The screw shall be, at a minimum, 16" Diameter, abrasion resistant construction, full pitch right-hand shaftless screw, 3" wide x 1" thick outer flight, with 1.5" wide x 5/8" thick inner flight double V-groove welds with welded flange bolted connections at the drive end.

C. Supports

1. A minimum of ten floor supports shall be provided, and shall be constructed of 316 stainless steel. Supports shall be designed by the manufacturer for the equipment dead loads and live loads, and shall be furnished and installed by the CONTRACTOR. Field measurements will be required.

D. Drive

1. The drive unit shall be a hollow shaft mounted gear motor rated at a minimum AGMA Class II, single or double reduction or triple reduction. A 7.5-HP 230/460/3/60 TEFC constant speed drive shall be provided at the discharge end of the conveyor. Reducers shall be provided to run the conveyor at approximately 20 RPM.
2. The drive shaft shall be, at a minimum, 3" diameter welded to spiral and with sealed housing at tail and connected to the spiral to effectively transmit torque from the drive shaft to the flight.

2.2 Inclined Screw Compactor

A. Screw Trough and Chutes

1. The screw trough shall be fabricated from 316 stainless steel. Inlet hopper and screw trough shall be constructed of minimum 1/8" steel.
2. A drain box shall be provided at the inlet end of the conveyor. A brush shall be provided at the drain box.
3. A tubular discharge pipe shall be provided with an internal support bushing. A flexible discharge line shall be furnished.

B. Shafted Screw

1. The screw shall be, at a minimum, 9" Diameter, abrasion resistant construction, full pitch shafted screw.

C. Wash Module

1. A spray wash module shall be furnished and installed by the CONTRACTOR.
2. The piping shall be 316 stainless steel.

D. Supports

1. Floor supports shall be provided for incline conveyor support, and shall be constructed of 316 stainless steel. Supports are to be sized by the manufacturer and furnished and installed by the CONTRACTOR. Field measurements will be required.

E. Drive

3. The drive unit shall be a hollow shaft mounted gear motor rated at a minimum AGMA Class II, single or double reduction or triple reduction. A 1.5-HP 230/460/3/60 TEFC 230/460, 60-hz 3-phase constant speed drive shall be provided at the discharge end of the conveyor running at approximately 20 RPM.
4. The drive shaft shall be, at a minimum, 1.5" diameter welded to spiral and with sealed housing at tail and connected to the spiral to effectively transmit torque from the drive shaft to the flight.

F. Controls

1. The controls for the inclined conveyor shall be integrated with those for the horizontal screw conveyor.

2.3 Controls

1. Furnish and install one NEMA 4X 316 stainless steel control panel. Panel shall include the following:
 - a. Disconnect switch with external operating handle.
 - b. Control transformer with fusing.
 - c. Branch circuit breaker.
 - d. Full voltage reversing (FVR) size 1 motor starters with auxiliary contacts.

- e. Current sensing overload relays.
 - f. Time delay relays.
 - g. Control relays.
 - h. Pilot lights for run/stop for each unit.
 - i. Emergency stop pushbuttons for each unit.
 - j. Reset pushbutton for each unit.
 - k. 3 position H-O-A selector switches for each unit.
 - l. 3 position F-O-R selector switches for each unit.
2. Each conveyor shall be equipped with a zero speed switch, and an emergency stop pull cord mounted on the side of the conveyor.
 3. Refer to part 2.5 for description of controls.

2.4 Manufacturers

- A. The conveyor equipment shall be manufactured by one of the following:
 1. U.S. Filter Link-Belt Products.
 2. Parkson Corporation.
 3. Approved Equal.

2.5 Details of Construction

A. Mechanical Work

1. The CONTRACTOR shall remove and salvage the existing horizontal and inclined belt conveyors. Units shall be left outside of the screening building for the OWNER.
2. The CONTRACTOR shall furnish and install mounting and support units for the new conveyors. Sizing of the mounting legs shall be by the equipment manufacturer. Anchor bolt size and embedment shall be as recommended by the equipment manufacturer.
3. All fasteners and anchor bolts shall be provided by the CONTRACTOR, and shall be 316 stainless steel. Anchor bolts shall be drilled and grouted into the existing slab.
4. Drain piping shall be furnished and installed by the CONTRACTOR to rout excess water from the conveyors back into the plant headworks/bar screen channels. Piping size shall be as recommended by the equipment manufacturer, but shall not be less than 4". Pipe shall be PVC.
5. Discharge chutes shall be furnished and installed to connect the outlets of the bar screens with the inlets to the horizontal conveyor.
 - a. Neoprene chutes (18" W x 58" L) for Bar Screen No. 2, 3 and 4 have been provided by the manufacturer and are available for the CONTRACTOR's use. Clearance from the slab to the chute bottom is approximately 57".
 - b. A discharge chute/connection for Bar Screen No. 1 shall be furnished and installed by the CONTRACTOR.
6. Refer to Figures 2 and 3 for more details of the work.

B. Electrical Details

1. The CONTRACTOR shall disconnect and remove all existing belt conveyor electrical equipment including local disconnects and wiring.
2. Existing power and control wiring shall be removed from 1-1/4" conduit running from the Bar Screens Building to the Influent Pump Station electrical room MCC-1B.
3. The new screw conveyor control panel shall be installed on the north wall of the Bar Screens building in the area of the removed belt conveyor junction box.
4. The new 480V power feed shall be run from the Influent Pump Station electrical room MCC-1B to the new screw conveyor control panel re-using existing 1-1/4" conduit.
5. Existing Screen Conveyor (E-104) MCC size-1 starter "bucket" shall be removed from MCC-1B compartment 4-D. Replace with a Fused Disconnect type "bucket." The MCC disconnect shall be a 60 amp frame with 30 amp fuses. Number 10 AWG conductors shall be used for the 480V power feed to the new screw conveyor control panel.
6. New 3/4" conduit and wiring shall be furnished and installed from the new screw conveyor control panel (starter) to each of the new screw conveyor motors.
7. New conduit and wiring shall be furnished and installed from the Screw Conveyor Control Panel to the zero-speed and safety pull-rope switches located on each of the new screw conveyors.
8. For automatic control of the screw conveyors, new conduit and wiring shall be furnished and installed from the screw conveyor control panel (Bar Screens Building) to each of the bar screen local control panels 1-4 (Bar Screens Building.) "Forward" run contacts from each Bar Screen Local Control Panel shall be parallel-wired into the start circuit for the screw conveyors.
9. Refer to Figure 4 for all electrical details.

C. Controls

1. Each of the units is to be provided with HOA and FOR switches. In the hand mode, a unit will be operated by the FOR switch. In the auto mode, the horizontal conveyor will operate when any of the screens are operating, and will stop when no screens are operating. The off position shall be lockable.
2. The inclined conveyor will operate only when the horizontal conveyor is in operation.
3. Part 2.5.B contains a description of the electrical work.

D. Curb Relocation

1. The concrete containment curb nearest the bar screen units shall be removed and re-poured at a new location by the CONTRACTOR to allow fastening of existing bar screens to the slab.
2. The existing curb, including all concrete and reinforcement, shall be removed and disposed of by the CONTRACTOR.
3. The new curb will be re-poured 12" from the original location, moving away from the bar screen units (toward the southeast wall of the facility).
4. Reinforcement shall be #4 bars, drilled and grouted into the existing slab at 12" spacing.

PART 3 - EXECUTION

3.1 Equipment Installation

All equipment shall be installed in accordance with the 1997 Standard Specifications, the recommendations of the manufacturer, and accepted construction practices.

3.2 Start-up

The CONTRACTOR shall provide the services of a qualified representative of the screw conveyor equipment manufacturer for a minimum of three days and two trips to check the installation, train operating personnel and start up new equipment.

3.3 Warranty

The CONTRACTOR shall guarantee all equipment, labor and materials against failure for a period of one year. The guarantee shall take effect on issuance date of the Final Acceptance Certificate for the project.

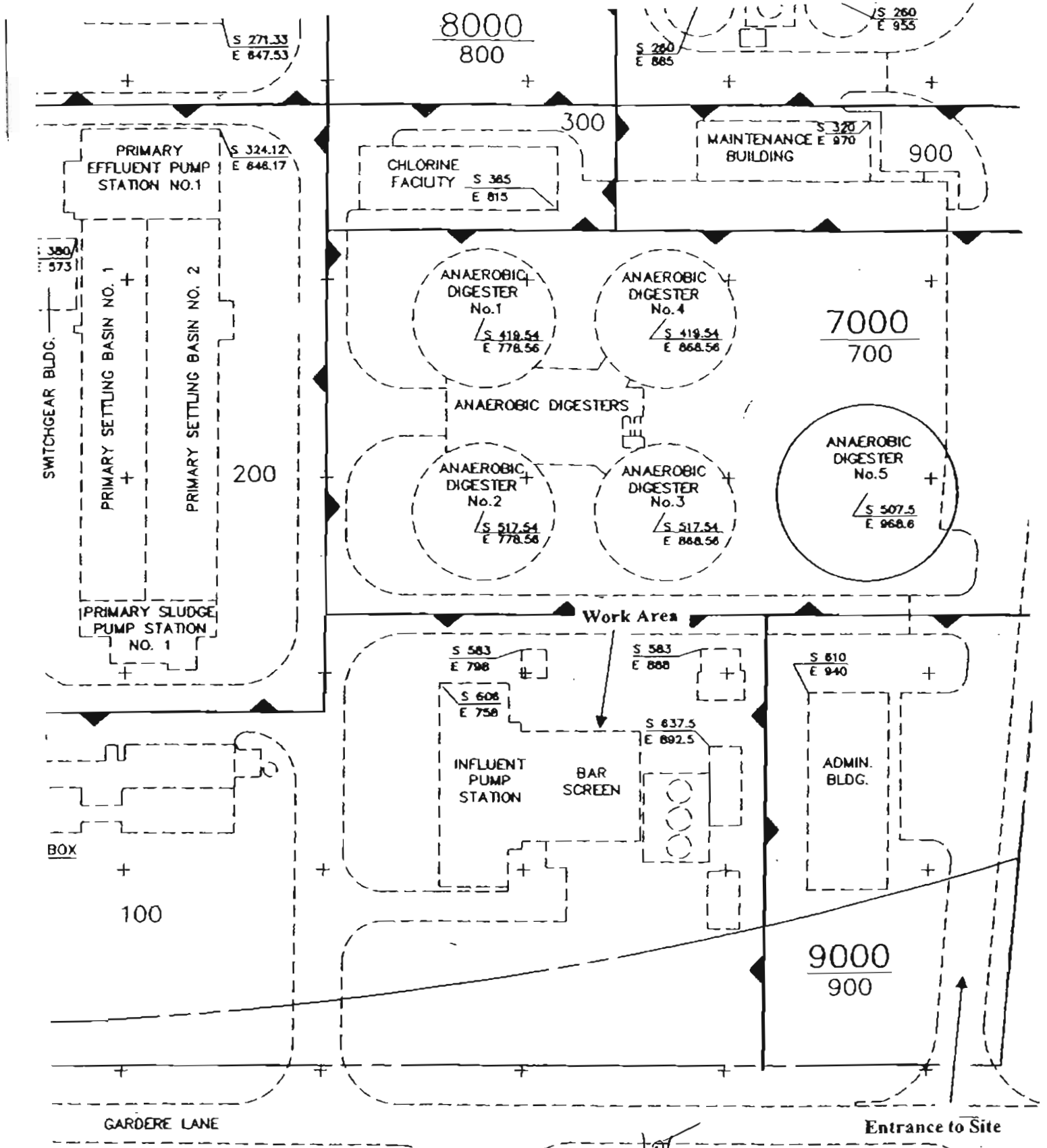

cur B. Walls 5/2/01

S.3.05

Figure 1 - Site Layout

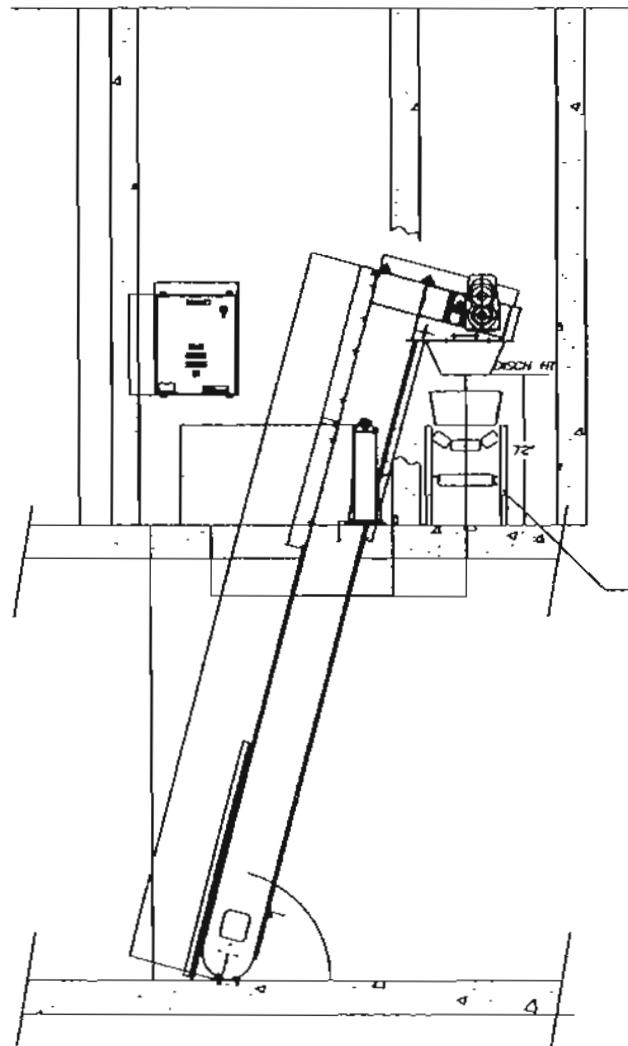

EXISTING CONVEYOR
(TO BE REMOVED
AND REPLACED)

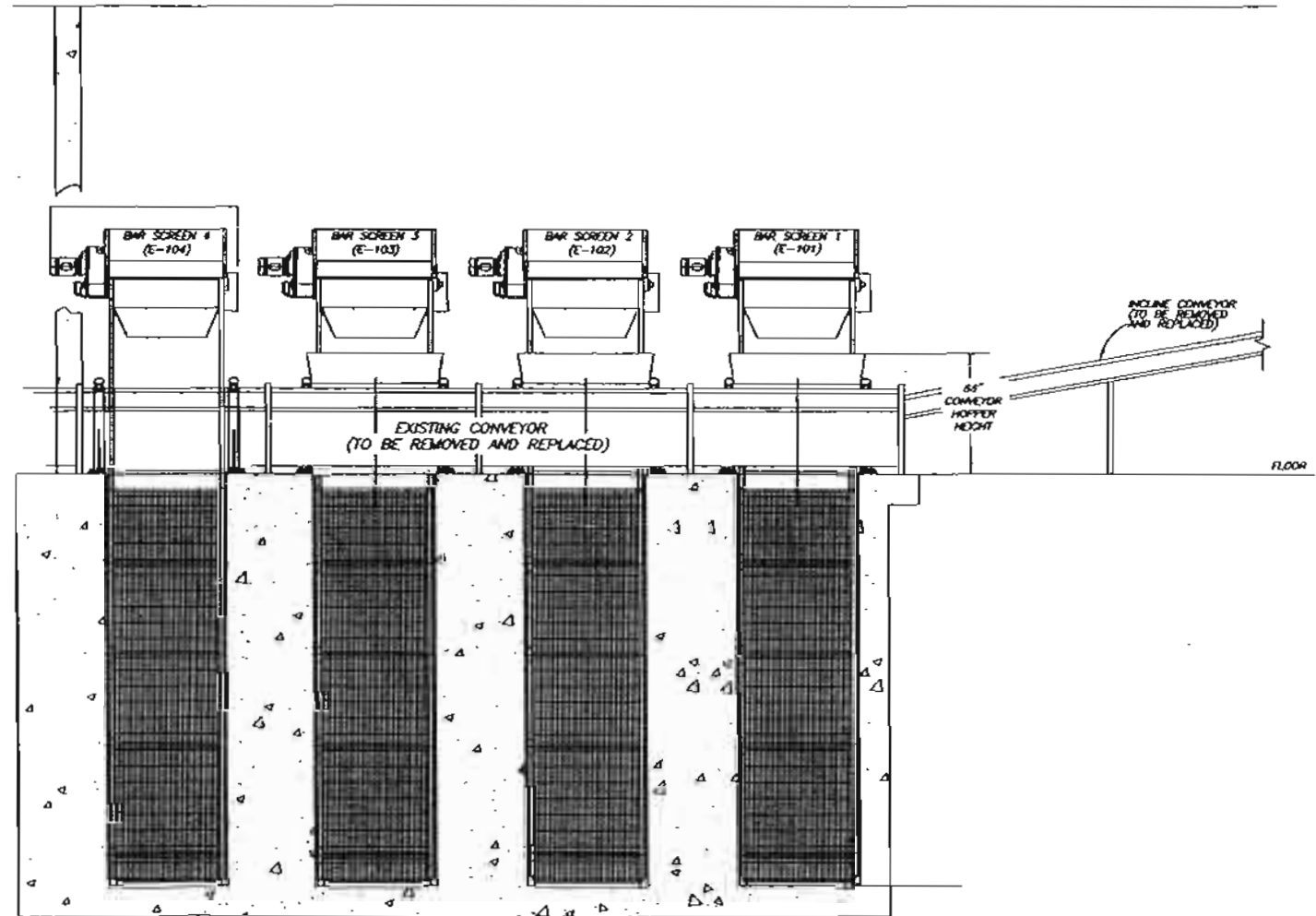

MECHANICAL BAR SCREEN

SCREENINGS CONVEYANCE
SOUTH WASTEWATER TREATMENT PLANT
FIGURE 2-EXISTING FACILITIES SECTIONS

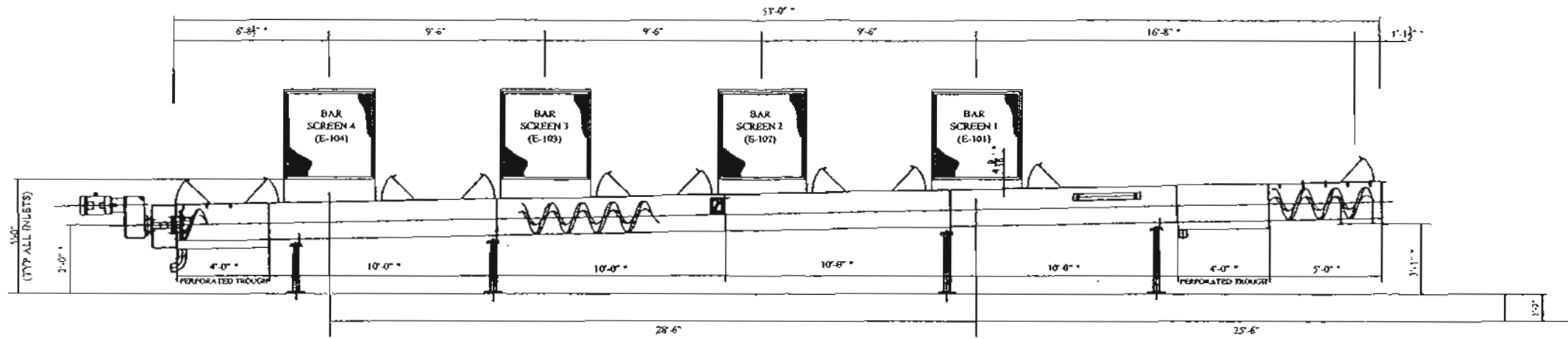

PROCESS SCREENINGS DEWATERING
TRANSFER SCREW

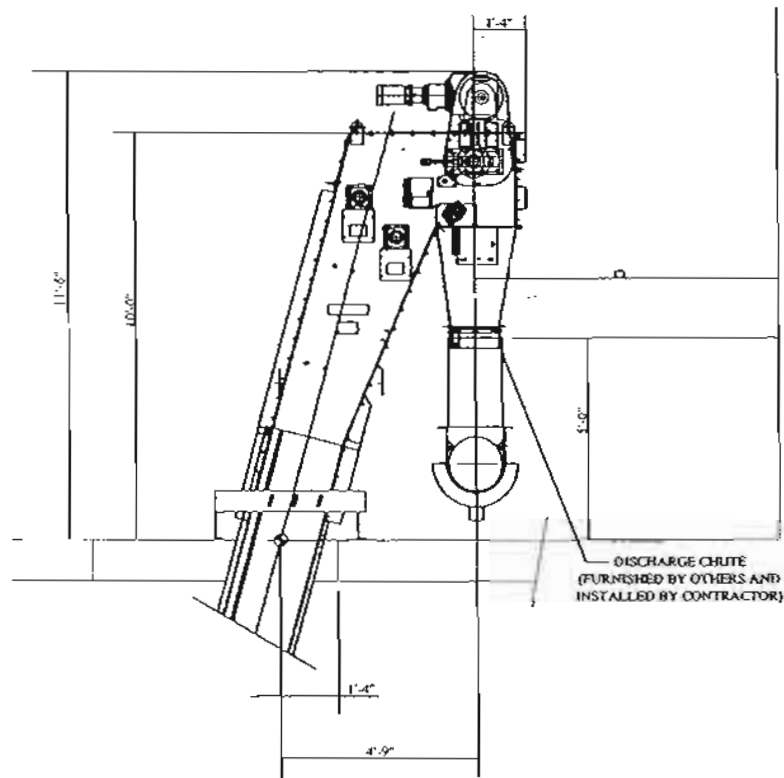

ELEVATION VIEW OF PROPOSED
SCREENINGS HANDLING SYSTEM

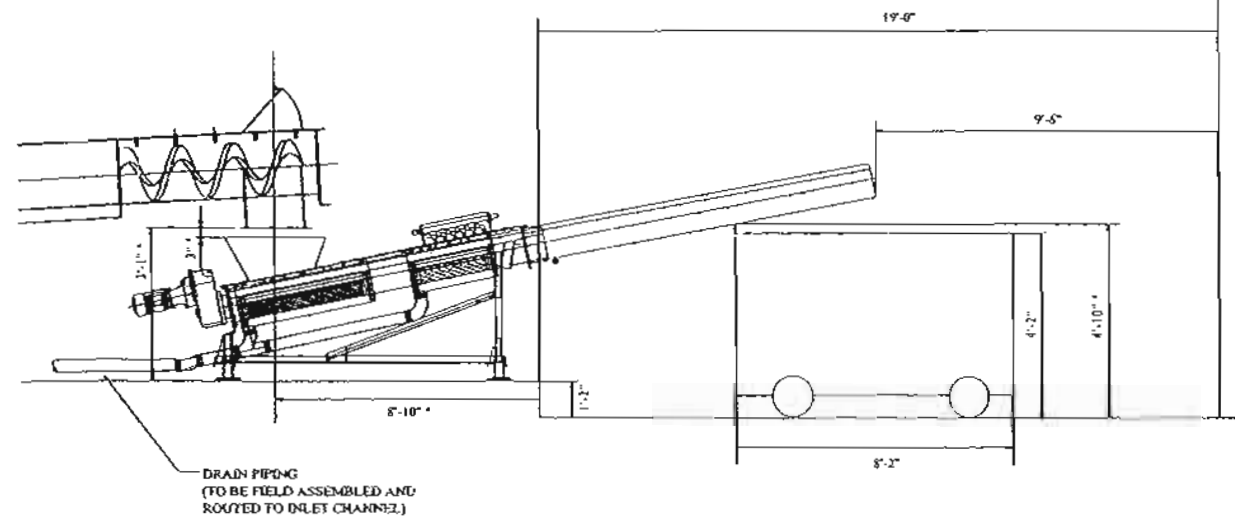

PROPOSED INCLINED CONVEYOR
WITH WASH MODULE (SHAFTED SCREW TYPE)

* DIMENSION VARIES BASED ON EQUIPMENT APPROVED AND SUPPLIED

SCREENINGS CONVEYANCE
SOUTH WASTEWATER TREATMENT PLANT
FIGURE 3-PROPOSED CONVEYANCE SYSTEM SECTIONS
NO SCALE

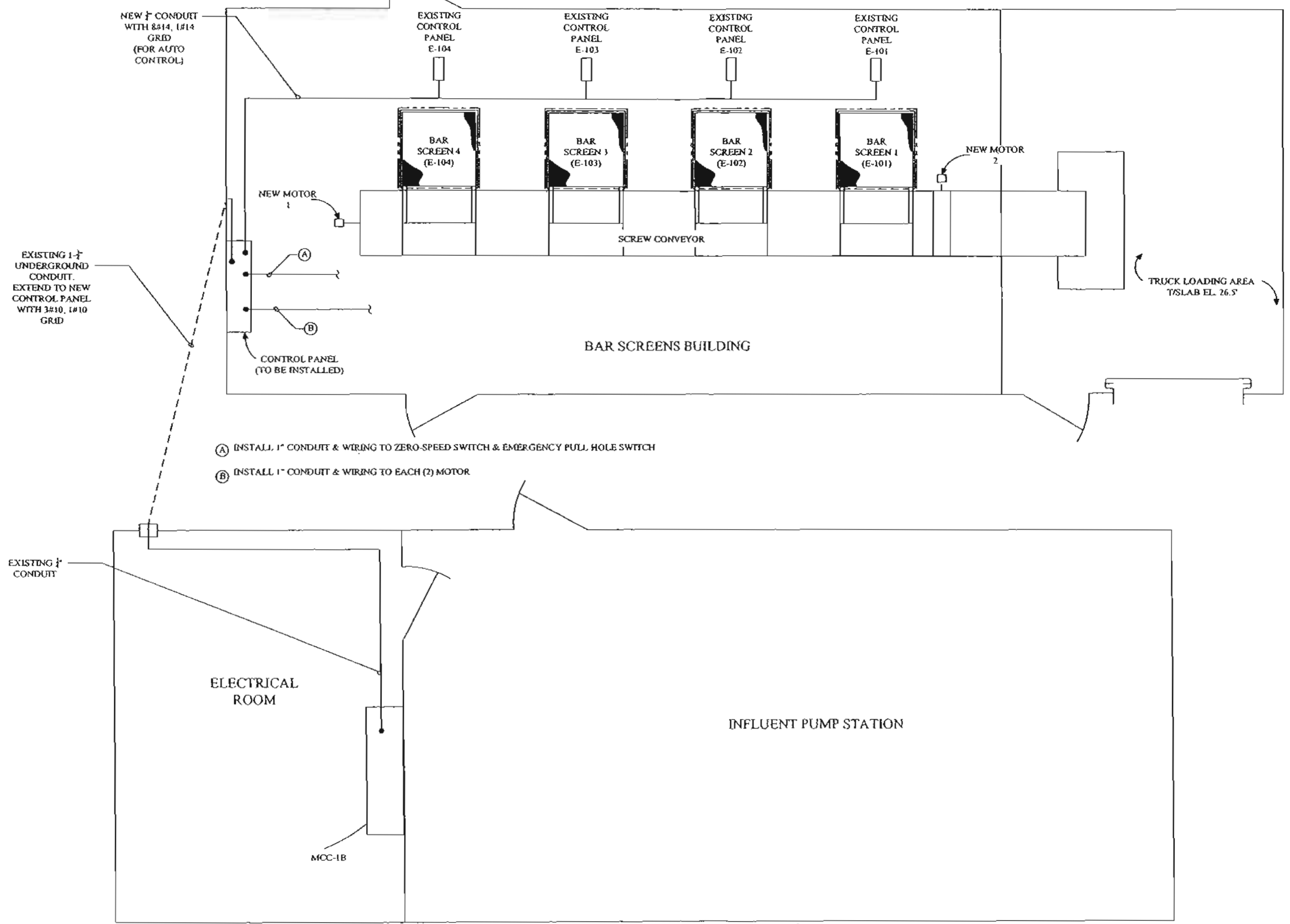

SCREENINGS CONVEYANCE
 SOUTH WASTEWATER TREATMENT PLANT
 FIGURE 4-FACILITY PLAN/ELECTRICAL DETAILS

Appendix D

March 15, 2005

**LIST OF APPROVED APPLICANTS
FOR SEWER LINE ASSISTANCE**

1. **Mrs. Johnnie Ella Wheat**
7666 Gov. Blanchard Drive
775-6919
2. **Mrs. Virginia Tyler**
9704 Foster Road
774-4714
3. **Ms. Carolyn Butler**
9089 Cefalu Drive
356-5187
4. **Ms. Octavia Johnson**
9035 Cefalu Drive
771-2680
5. **Mr. Cyril J. Holley**
9644 Foster Drive
775-3220

March 15, 2005

**LIST OF APPROVED APPLICANTS
FOR SEWER LINE ASSISTANCE**

- 1. M/M Rodney/Stephaine Franklin
6425 Guynell Drive
356-9421**

- 2. Ms. Pernelia Rogers
9234 Junelise Drive
355-2480**

May 16, 2005

**LIST OF APPROVED APPLICANTS
FOR SEWER LINE ASSISTANCE**

1. **Ms. Albertha Young**
542 Williams Street
774-6996

June 8, 2005

**LIST OF APPROVED APPLICANTS
FOR SEWER LINE ASSISTANCE**

1. **Ms. Janet Robertson**
8854 Mable Drive
Baton Rouge, La. 70811
356-6818

2. **Ms. Vickey/Marvin Breaud**
8687 Cortlett Drive
Baton Rouge, La. 70811
355-0447

3. **Ms. Ruth Boyd**
9121 Cefalu Drive
Baton Rouge, La. 70811
356-1437

June 8, 2005

**LIST OF APPROVED APPLICANTS
FOR SEWER LINE ASSISTANCE**

1. **Ms. Janet Robertson**
8854 Mable Drive
Baton Rouge, La. 70811
356-6818

2. **Ms. Vickey/Marvin Breaud**
8687 Corlett Drive
Baton Rouge, La. 70811
355-0447

3. **Ms. Ruth Boyd**
9121 Cefalu Drive
Baton Rouge, La. 70811
356-1437

4. **Ms. Delores Kelley**
8689 Cedar Glen Drive
Baton Rouge, La. 70811
357-3530

July 6, 2005

**LIST OF APPROVED APPLICANTS
FOR SEWER LINE ASSISTANCE**

1. **Antonio/Jennifer Pacheco**
8645 Cedar Glen Drive
357-3993

2. **Stacey/Randel Sanchez**
8667 Cedar Glen Drive
356-6787

August 22, 2005

**LIST OF APPROVED APPLICANTS
FOR SEWER LINE ASSISTANCE**

1. **JAMES, Barbara**
9124 Cefalu Drive
356-3657

2. **DEAMER, Florida**
8665 Corlett Drive
356-5828

3. **WALLACE, Karen**
8566 Sharon Hills Blvd.
356-6862

4. **SMITH, Leroy**
7784 Gov. Wickliffe Avenue
775-5367 or 772-3211

5. **WALTON, Mary**
8475 Sharon Hills Blvd.
356-8829

October 24, 2005

**LIST OF APPROVED APPLICANTS
FOR SEWER LINE ASSISTANCE**

- | | | |
|----|--|--------------------|
| 1. | CROUSILLAC, Margaret
8722 Cedar Glen Drive
261-6050 | <i>JAMES NEARY</i> |
| 2. | MCCUTCHEON, Glamorie
8933 Mable Drive
356-0512 | <i>JAMES NEARY</i> |
| 3. | MCCLAY, Fannie
7768 Gov. Wickliffe
774-7987 | <i>TED HEBERT</i> |
| 4. | SMITH, Coralie D.
9352 Cedar Glen Drive | <i>TED HEBERT</i> |